

**TM 5-6675-322-14**

---

**TECHNICAL MANUAL**

**OPERATOR'S, ORGANIZATIONAL, DIRECT  
SUPPORT AND GENERAL SUPPORT  
MAINTENANCE MANUAL**

**TOPOGRAPHIC SUPPORT SYSTEM  
COLLECTION SECTION  
MODEL ADC-TSS-11  
NSN: 6675-01-105-5760**

**THIS MANUAL SUPERSEDES TM 5-6675-322-14 DATED 9 JUNE 1983**

---

**HEADQUARTERS, DEPARTMENT OF THE ARMY**

**20 JUNE 1985**



CHANGE  
NO. 3

HEADQUARTERS  
DEPARTMENT OF THE ARMY  
WASHINGTON, D.C., 3 JULY 1992

Operator's, Organizational, Direct  
Support and General Support  
Maintenance Manual

**TOPOGRAPHIC SUPPORT SYSTEM  
COLLECTION SECTION  
MODEL ADC-TSS-11  
NSN 6675-01-105-5760**

Approved for public release; Distribution is unlimited

TM 5-6675-322-14, 20 June 1985 is changed as follows:

1. Remove and insert pages as indicated below. New or changed text material is indicated by a vertical bar in the margin. An illustration change is indicated by a miniature pointing hand.

Remove pages

Insert pages

C-1 and C-2

C-1 and C-2

2. Retain this sheet in front of manual for reference purposes.

**By Order of the Secretary of the Army:**

GORDON R. SULLIVAN  
General, *United States Army*  
*Chief of Staff*

Official:

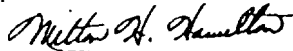

MILTON H. HAMILTON  
*Administrative Assistant to the  
Secretary of the Army*

01920

**DISTRIBUTION:**

To be distributed in accordance with DA Form 12-25E, (qty rqr block no. 1861).



CHANGE }  
NO. 2 }

HEADQUARTERS  
DEPARTMENT OF THE ARMY  
WASHINGTON, D.C., 14 April 1988

Operator's, Organizational, Direct  
Support and General Support  
Maintenance Manual

**TOPOGRAPHIC SUPPORT SYSTEM  
COLLECTION SECTION  
MODEL ADC-TSS-11  
NSN: 6675-01-105-5760**

TM 5-6675-322-14, 20 June 1985, is changed as follows:

1. Remove and insert pages as indicated below. New or changed text material is indicated by a vertical bar in the margin. An illustration change is indicated by a miniature pointing hand.

Remove pages

Insert pages

1-19 and 1-20

1-19 and 1-20

2. Retain this sheet in front of manual for reference purposes.

**By Order of the Secretary of the Army:**

**CARL E. VUONO**  
*General, United States Army*  
*Chief of Staff*

**Official:**

**R. L. DILWORTH**  
*Brigadier General, United States Army*  
*The Adjutant General*

**DISTRIBUTION:**

To be distributed in accordance with DA Form 12-25A, Operator, Unit, Direct Support and General Support Maintenance requirements for Topographic Support System, Collection Section (ADC-TSS-11)



CHANGE

NO. 1

HEADQUARTERS  
DEPARTMENT OF THE ARMY  
WASHINGTON, D.C., 29 August 1986

Operator's, Organizational, Direct  
Support and General Support  
Maintenance Manual

TOPOGRAPHIC SUPPORT SYSTEM  
COLLECTION SECTION  
MODEL ADC-TSS-11  
NSN: 6675-01-105-5760

TM 5-6675-322-14, 20 June 1985, is changed as follows:

1. Remove and insert pages as indicated below. New or changed text material is indicated by a vertical bar in the margin. An illustration change is indicated by a miniature pointing hand.

Remove pages

i and ii  
1-51 and 1-52  
1-55 and 1-56  
1-61 through 1-64  
1-73 and 1-74  
1-97 and 1-98  
1-101 and 1-102  
2-25 and 2-26  
2-29 and 2-30  
8-11 and 8-12  
8-15 and 8-16  
B-5 through B-8  
C-1 and C-2  
C-5 through C-17/C-18  
D-1 and D-2  
E-1 through E-9/E-10

Insert pages

i and ii  
1-51 and 1-52  
1-55 and 1-56  
1-61 through 1-64  
1-73 and 1-74  
1-97 and 1-98  
1-101 and 1-102  
2-25 and 2-26  
2-29 and 2-30  
8-11 and 8-12  
8-15 and 8-16  
B-5 through B-8  
C-1 and C-2  
C-5 through C-17/C-18  
D-1 and D-2  
E-1 through E-8

2. Retain this sheet in front of manual for reference purposes.

**By Order of the Secretary of the Army:**

**JOHN A. WICKHAM, JR.**  
*General, United States Army*  
*Chief of Staff*

**Official:**

**R. L. DILWORTH**  
*Brigadier General, United States Army*  
*The Adjutant General*

**DISTRIBUTION:**

To be distributed in accordance with DA Form 12-25A, Operator, Organizational, Direct Support and General Support Maintenance Requirements for Topographic Support System, Collection Section (ADCTSS-11)





---

**WARNING**

---

HIGH VOLTAGE is used in this equipment. DEATH ON CONTACT or severe injury may result if personnel fail to observe safety precautions.

Do not be misled by the term LOW VOLTAGE. Low voltage can cause serious injury or death.

Test procedures requiring the operator or maintenance personnel to investigate equipment or restore casualties with interlocks disconnected or covers removed may result in DEATH ON CONTACT if personnel fail to observe safety precautions.

Voltages in switches and circuit breaker panels may result in DEATH ON CONTACT if personnel fail to observe safety precautions.

Failure to ground the section or equipment may result in DEATH ON CONTACT if personnel fail to observe safety procedures.

---

**WARNING**

---

Dry cleaning solvent, P-D-680, used to clean parts is potentially dangerous to personnel and property. Avoid repeated and prolonged skin contact. Wear solvent-impermeable gloves and eye/face protective equipment when using solvent. Do not use near open flame or excessive heat. Flash point of solvent is 100°F to 138°F (38°C to 59°C).

For Artificial Respiration refer to FM 21-11.

---

**WARNING**

---

Rotating and spinning equipment may snag loose clothing, hair or jewelry resulting in SEVERE PERSONNEL INJURY.

---

**WARNING**

---

Attempting to move overweight or top heavy equipment that is unsecured may result in SEVERE PERSONNEL INJURY. Always have sufficient personnel and equipment to accomplish the task.



TECHNICAL MANUAL  
NO. 5-6675-322-14

HEADQUARTERS  
DEPARTMENT OF THE ARMY  
WASHINGTON, D.C., 20 June 1985

Operator's, Organizational, Direct Support and  
General Support Maintenance Manual

TOPOGRAPHIC SUPPORT SYSTEM  
COLLECTION SECTION  
MODEL ADC-TSS-11  
NSN: 6675-01-105-5760

**REPORTING ERRORS AND RECOMMENDING IMPROVEMENTS**

You can help improve this manual. If you find any mistake or if you know of a way to improve the procedures, please let us know. Mail your letter, DA Form 2028 (Recommended Changes to Publications and Blank Forms), or DA Form 2028-2 located in the back of this manual direct to: Commander, U.S. Army Troop Support Command, ATTN:AMSTR-MCTS, 4300 Goodfellow Boulevard, St. Louis, MO 63120-1798. A reply will be furnished directly to you.

TABLE OF CONTENTS

	Page
CHAPTER 1.           COLLECTION SECTION. . . . .	1-1
Section I        Introduction. . . . .	1-1
Section II       Operating Instructions . . . . .	1-12
Section III      Operator Maintenance . . . . .	1-45
Section IV      Organizational Maintenance . . . . .	1-53
Section V       Direct/General Support Maintenance . . . . .	1-90
CHAPTER 2.           DRAFTING, SCRIBING/TRACING TABLE . . . . .	2-1
Section I        Introduction. . . . .	2-1
Section II       Operating Instructions . . . . .	2-4
Section III      Operator Maintenance . . . . .	2-12
Section IV      Organizational Maintenance . . . . .	2-15
Section V       Direct/General Support Maintenance . . . . .	2-35
CHAPTER 3.           POCKET CALCULATOR . . . . .	3-1
Section I        Introduction. . . . .	3-1
Section II       Operating Instructions . . . . .	3-4
Section III      Operator Maintenance . . . . .	3-35
Section IV      Organizational Maintenance . . . . .	3-36
Section V       Direct/General Support Maintenance . . . . .	3-37
CHAPTER 4.           STEREOMETER PARALLAX BAR . . . . .	4-1
Section I        Introduction . . . . .	4-1
Section II       Operating Instructions . . . . .	4-3
Section III      Operator Maintenance . . . . .	4-15
Section IV      Organizational Maintenance . . . . .	4-15
Section V       Direct/General Support Maintenance . . . . .	4-16

CHAPTER 5.	LENS-PRISM-MIRROR STEREOSCOPE . . . . .	5-1
Section I	Introduction . . . . .	5-1
Section II	Operating Instructions . . . . .	5-3
Section III	Operator Maintenance . . . . .	5-11
Section IV	Organizational Maintenance . . . . .	5-14
Section V	Direct/General Support Maintenance . . . . .	5-14
CHAPTER 6.	ULTRASONIC CLEANER. . . . .	6 - 1
Section I	Introduction . . . . .	6 - 1
Section II	Operating Instructions . . . . .	6 - 3
Section III	Operator Maintenance . . . . .	6 - 8
Section IV	Organizational Maintenance . . . . .	6 - 9
Section V	Direct/General Support Maintenance . . . . .	6-17
CHAPTER 7.	FACSIMILE TRANSMISSION AND RECEIVING DEVICE . . . . .	7 - 1
Section I	Introduction . . . . .	7 - 1
CHAPTER 8.	FURNITURE AND CABINETS . . . . .	8-1
Section I	Introduction. . . . .	8-1
Section II	Operating Instructions . . . . .	8-3
Section III	Operator Maintenance . . . . .	8-4
Section IV	Organizational Maintenance . . . . .	8-4
Section V	Direct/General Support Maintenance . . . . .	8-17
CHAPTER 9.	SUPPORT ITEMS . . . . .	9-1
Section I	Introduction. . . . .	9-1
Section II	Operating Instructions . . . . .	9-3
Section III	Operator Maintenance . . . . .	9-65
Section IV	Organizational Maintenance . . . . .	9-77
Section V	Direct/General Support Maintenance . . . . .	9-80
APPENDIX A	REFERENCES . . . . .	A-1
APPENDIX B	MAINTENANCE ALLOCATION CHART . . . . .	B-1
APPENDIX C	COMPONENTS OF END ITEM AND BASIC ISSUE ITEMS LIST . . . . .	C-1
APPENDIX D	ADDITIONAL AUTHORIZATION LIST . . . . .	D-1
APPENDIX E	EXPENDABLE/DURABLE SUPPLIES AND MATERIALS LIST . . . . .	E-1
GLOSSARY.		GLOSSARY-1
INDEX . . . . .		INDEX-1



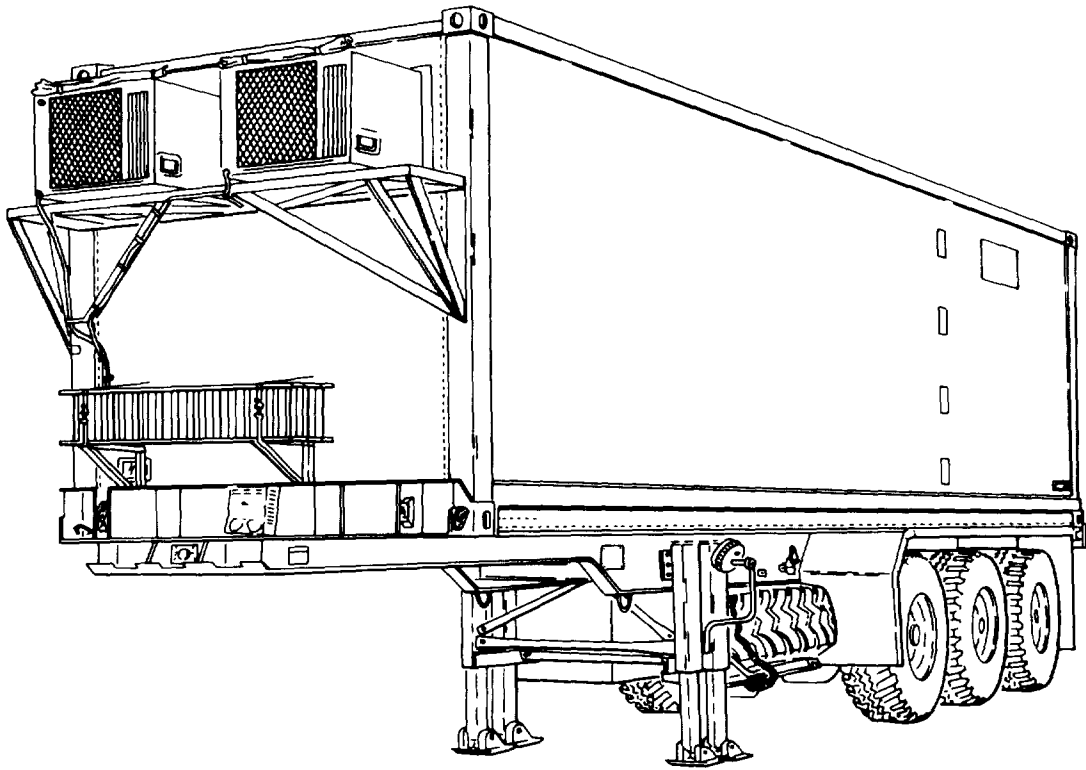

## CHAPTER 1

## COLLECTION SECTION

## Section I INTRODUCTION

**1-1. GENERAL INFORMATION.**

1-1.1 Scope. This manual contains operating and maintenance instructions for the ADC-TSS-11, Collection Section, Topographic Support System (TSS). The purpose of the Collection Section is to provide a focal point for supervision of topographic operations. The trailer chassis is covered in TM 5-2330-305-14, Operator, Organizational, Direct Support and General Support Maintenance Manual, Topographic Support System, Chassis, Semitrailer, ISO Container Transporter. Repair parts and special tools are listed in TM 5-6675-322-24P, Organizational, Direct Support, and General Support Maintenance Repair Parts and Special Tools List, Collection Section, Topographic Support System. Lubrication instructions are contained in LO 5-6675-322-12, Lubrication Order, Collection Section, Topographic Support System. All authorized equipment, supplies, and their locations for transport are shown in Location and Description of Major Components of this manual.

1-1.2 Purpose of Equipment. To provide a transportable facility as a focal point for supervision of topographic operations.

1-1.3 Maintenance Forms and Records. Department of the Army forms and procedures used for equipment maintenance will be those prescribed by DA Pam 738-750, The Army Maintenance Management System (TAMMS).

1-1.4 Reporting Equipment Improvements (EIR's). If the Collection Section needs improvement, let us know. Send us an EIR. You, the user, are the only one who can tell us what you do not like about your equipment. Let us know why you do not like the design or performance. Put it on an SF 368 (Quality Deficiency Report). Mail it to us at: U.S. Army Troop Support Command, ATTN: AMSTR-QX, 4300 Goodfellow Blvd., St. Louis, MO 63120-1798. We will send you a reply.

1-1.5 Destruction of Material to Prevent Enemy Use. For information on destruction of material to prevent enemy use, refer to TM 750-244-3, Procedures for Destruction of Equipment to Prevent Enemy Use.

1-1.6 Preparation for Storage or Shipment.

- a. Perform your preparation for movement procedures.
- b. For administrative storage of equipment, refer to TM 740-90-1.
- c. The chapters of this manual describe special shipping instructions for major components located in the section.
- d. In the event this equipment must be removed from the section for repair or replacement, contact your battalion for packing and shipping instructions.

**1-2. EQUIPMENT DESCRIPTION.**

1-2.1 Equipment Characteristics, Capabilities, and Features.

- a. Air and sea transportable.
- b. Transportable cross-country capability when mounted on trailer chassis.
- c. Controlled internal environment.

1-2.2 Special Considerations.

a. Site must permit section to be leveled within  $\pm 2^\circ$ , be well drained, and provide adequate overhead concealment. Wooded areas and other obstacles must not impede movement of transporters.

b. Dispersal of topographic sections is limited to the length of electric power transmission cable available for unit generators.

c. During site selection, avoid overhead power transmission lines to prevent danger from electric shock or electromagnetic interference.

d. Power is normally supplied by 60 kW generators. Commercial electric power should be used if it is compatible and available.

e. Cross-country capability of sections and transporters is limited. Relocation should be accomplished over hard-surfaced, all-weather roads whenever possible.



1-2.3 Location and Description of Major Components.

## a. Roadside Exterior.

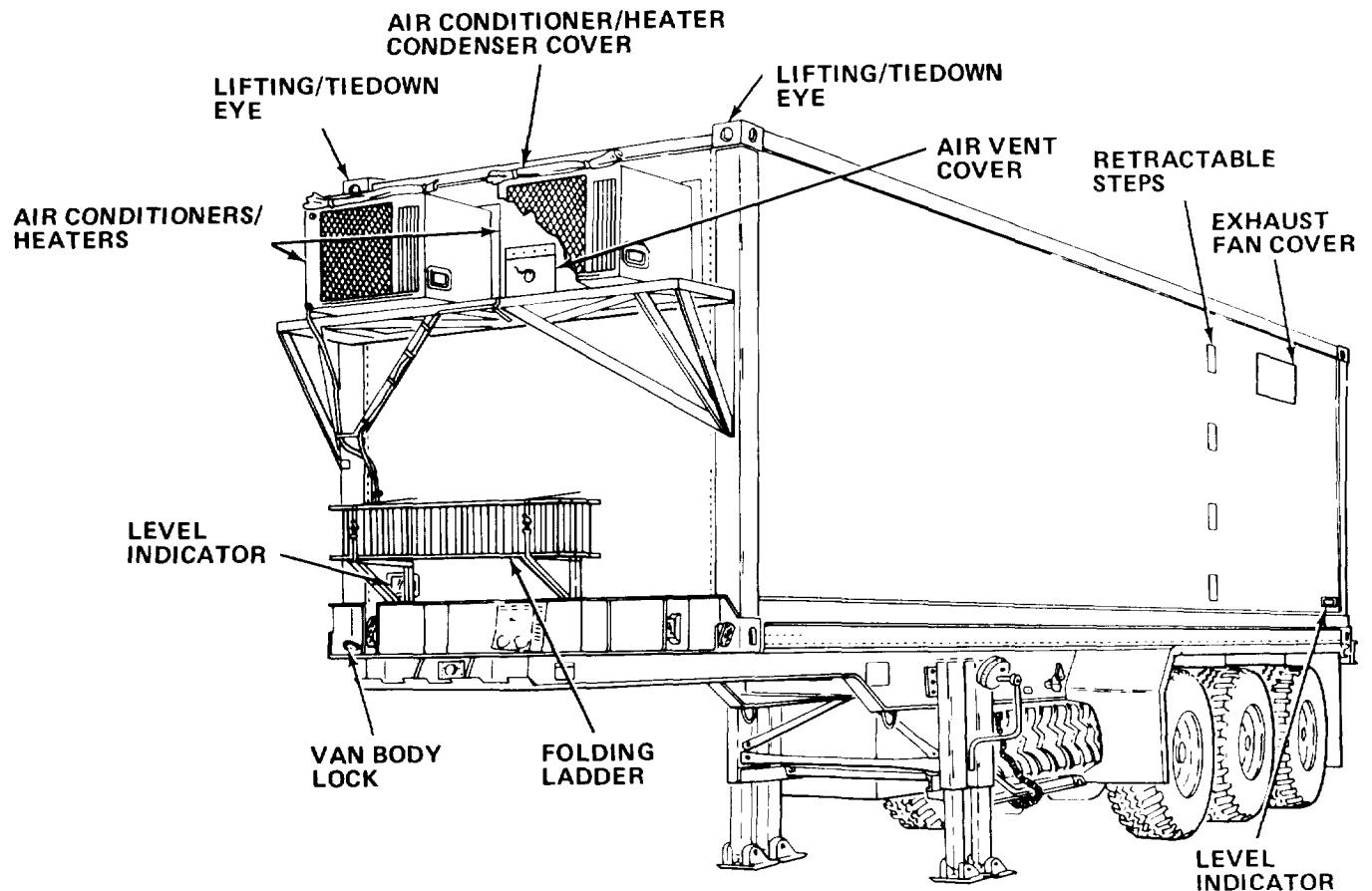

**VAN BODY LOCK.** Locks van body to trailer chassis.

**AIR CONDITIONERS/HEATERS.** Two air conditioner/heater units for internal environmental control.

**LIFTING/TIEDOWN EYES.** Attachment point for lifting or tying down van body.

**AIR CONDITIONER/HEATER CONDENSER COVER.** Covers air conditioner/heater condenser to prevent water/air entering air conditioner/heater unit when in transport or storage.

**AIR VENT COVER.** Covers air vent opening.

**RETRACTABLE STEPS.** Provide access to roof.

**EXHAUST FAN COVER.** Covers exhaust fan opening.

**LEVEL INDICATORS.** Indicate section inclination.

**FOLDING LADDER.** Allows access to air conditioners and top of section.

b. Curbside Exterior.

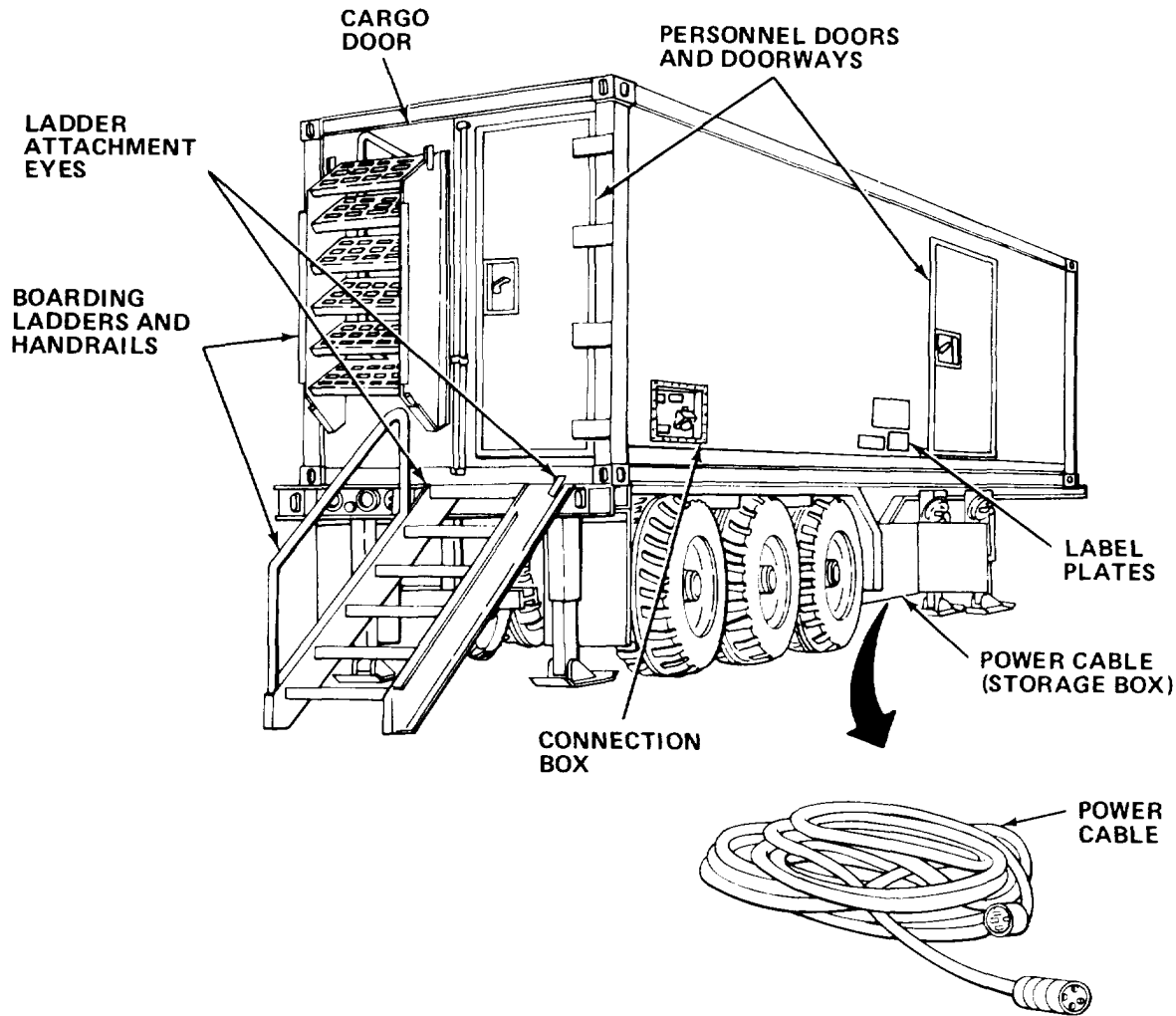

**CARGO DOOR.** Access for equipment removal/installation.

**PERSONNEL DOORS.** Doors are 35.75 in. (90.8 cm) wide by 86 in. (218.4 cm) high.

**PERSONNEL DOORWAYS.** Doorways are 30.75 in. (78.1 cm) wide by 78.5 in. (199.4 cm) high.

**LABEL PLATES.** Provide weight/moment data.

**POWER CABLE.** Power cable is in 50 ft (15.2 m) sections, (Stored in trailer chassis storage box.)

**CONNECTION BOX.** Contains terminals for ground cable, power cables, and telephone lines.

**LADDER ATTACHMENT EYES.** Attachment points for boarding ladder.

**BOARDING LADDERS AND HANDRAILS.** Provide access to section.

## c. Interior.

PERSONNEL DOOR. Weatherproof, fitted with blackout switch.

BLACKOUT SWITCH. Turns ceiling lights off when activated.

FIRE EXTINGUISHER. Dry chemical fire extinguisher.

CARGO DOOR. Access for equipment installation/removal.

FIRST AID KIT. Limited first aid supplies.

MAGNIFIER LAMP. Provides illumination and magnification for light table work station.

DRAFTING, SCRIBING/TRACING TABLE. Illuminated tracing board. Turns over for drafting board.

FLUORESCENT CEILING LAMP. White, two-level (high/low) overhead light.

EXHAUST FAN. Provides ventilation. Fitted with lightproof louvers and weatherproof cover.

BLACKOUT DOME LIGHT. Red-lensed, white-lensed 12 V ac light actuated when blackout switch operates, or from external power.

WALL STORAGE CABINET. Storage.

DESK. Work area.

TYPEWRITER DESK. Typing area.

FIELD PHONE MOUNT. Phone storage.

MANUAL TYPEWRITER. Used for typing.

SECURITY FILING CABINET. Storage of classified material.

AIR CONDITIONER/HEATER. Internal environmental control.

EMERGENCY LIGHTS. Battery-powered lighting actuated by power failure.

AIR VENT. Permits filtered make-up air to enter section.

FACSIMILE DEVICE. Transmits/receives graphics and text.

CORKBOARD. Display board.

BLACKOUT CURTAIN. Lightproof cover for personnel door.

SUPPLY CABINET. Storage.

SECURITY FILING CABINET. Classified stowage.

RIFLE RACK. Weapon storage.

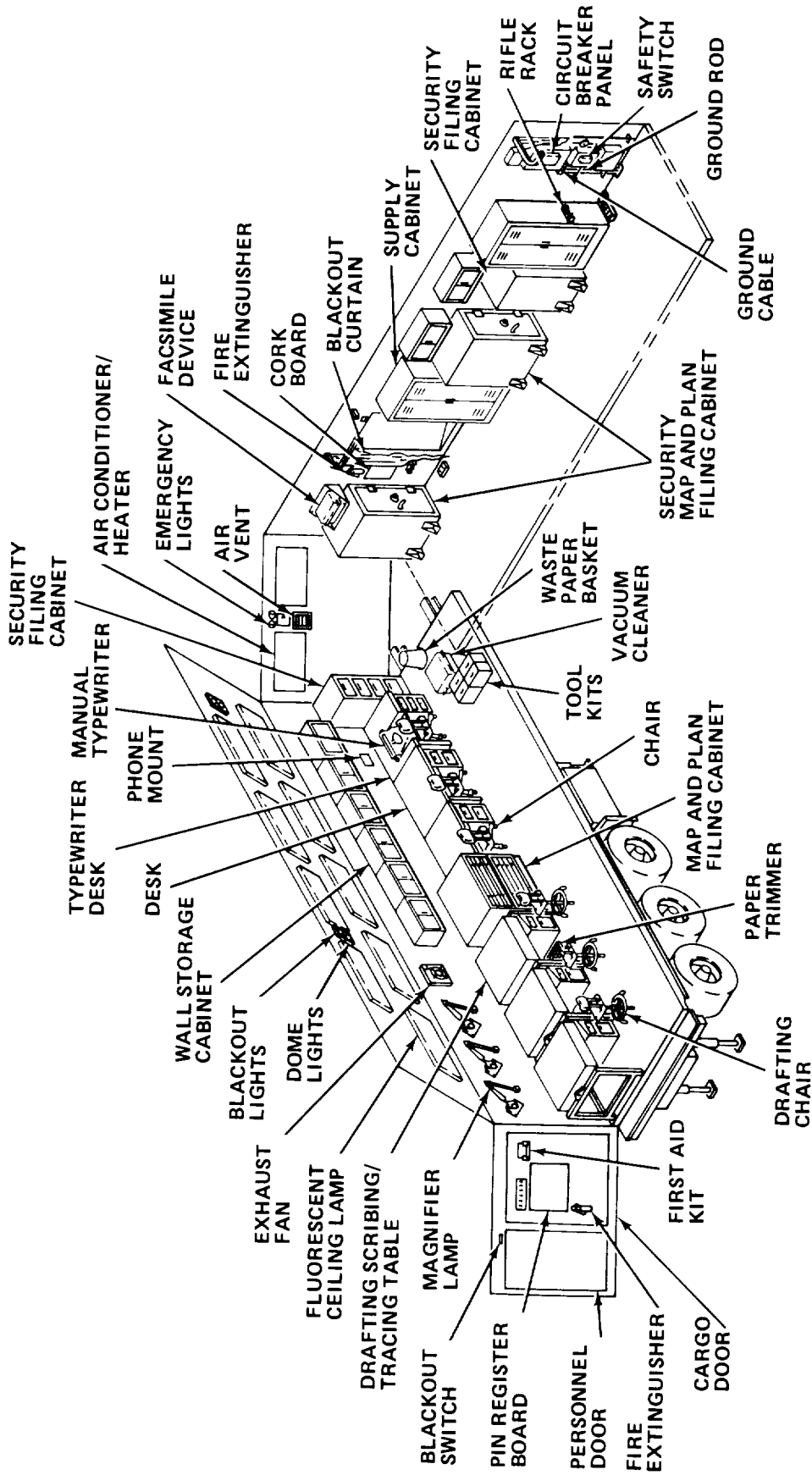

CIRCUIT BREAKER PANEL. Circuit breakers with phase test indicator.

SAFETY SWITCH. Main power safety disconnect switch.

GROUND ROD. Electrical ground for section.

GROUND CABLE. Used with ground rod.

SECURITY MAP AND PLAN FILING CABINET. Classified map stowage.

WASTEPAPER BASKET. Storage for transport.

VACUUM CLEANER. Cleaning equipment.

TOOL KITS.

CHAIR. Used at desk work station.

MAP AND PLAN FILING CABINET. Storage for maps/topographic products.

PAPER TRIMMER. Trims sheet paper.

DRAFTING CHAIR. Adjustable height chair.

PIN REGISTER BOARD. Punching holes.

1-2.4 Equipment Data - ISO Container (Unmounted).

Dimensions	
Length	33.66 ft (10.26 m)
Width	8 ft (2.44 m)
Height	8 ft (2.44 m)
Cubage	2038 ft <sup>3</sup> (57.7 m <sup>3</sup> )
Connections	
Telephones	One telephone (three-post) connection
Power	12.8 kW. One 120/208 V, three-phase, four-wire connection and one 12 V dc connection
Ground	Ground lug
Air Conditioner/Heater (Two Units)	
Cooling	18,000 Btu/hr (5274 W) each
Heating	14,300 Btu/hr (4190 W) (Max) each
Power Requirements	208 V, 60 Hz, three-phase
Exhaust Fan	289 ft <sup>3</sup> /min (8.18 m <sup>3</sup> /min)
Air Vent	289 ft <sup>3</sup> /min (8.18 m <sup>3</sup> /min)
Weight	
Gross (Container and Chassis)	27,870 lbs (12,641.75 kg)
Tare (Container Only)	16,430 lbs (7452.60 kg)

**1-3. TECHNICAL PRINCIPLES OF OPERATION.**

1-3.1 General. The operation of major components located within the section are explained in the appropriate chapter for that equipment.

1-3.2 Electrical System.

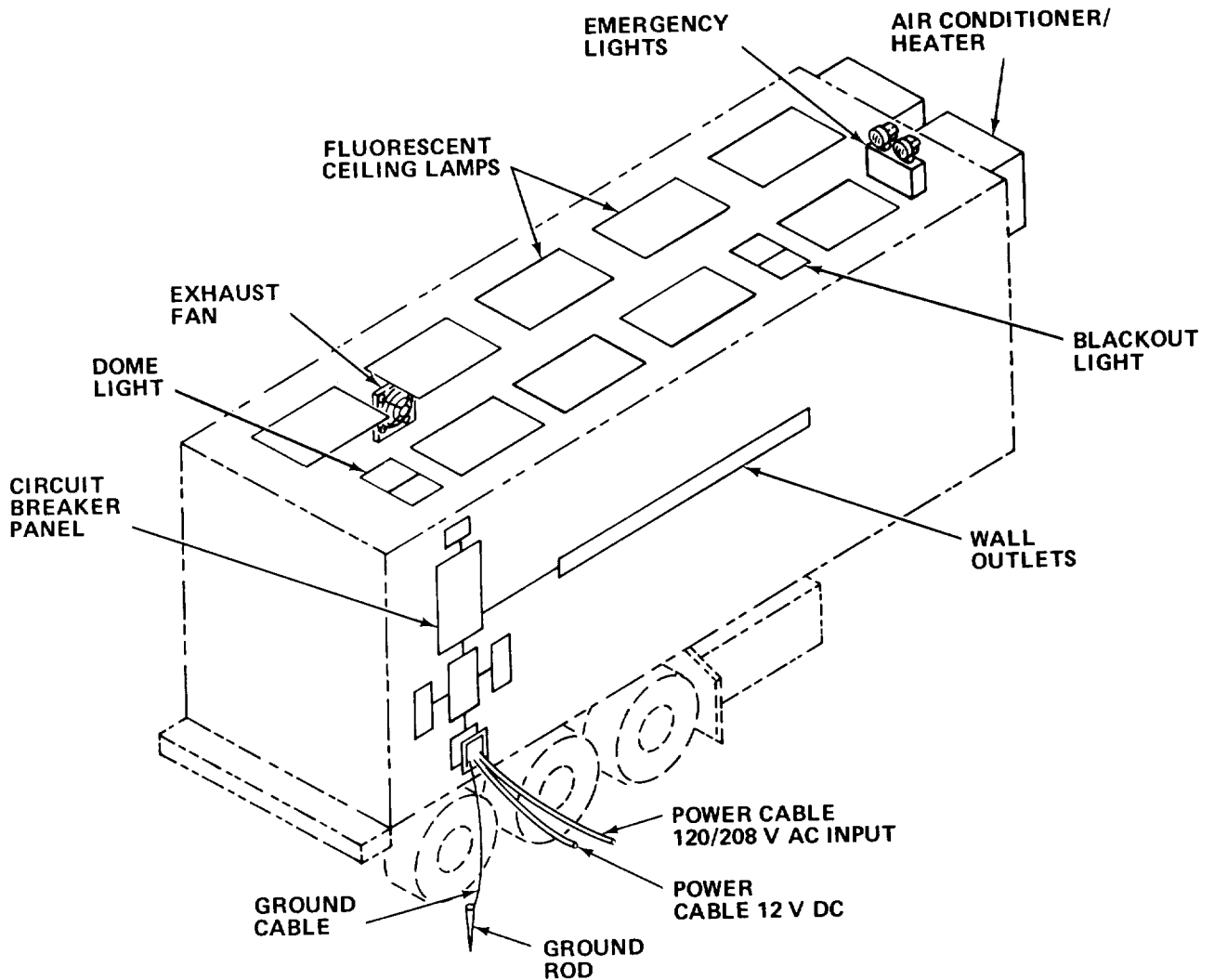

GROUND ROD . Used to ground section.

GROUND CABLE. Used with ground rod.

CIRCUIT BREAKER PANEL. Contains voltage indicator, phase monitor, and circuit breakers.

WALL OUTLETS. Provide grounded outlets for portable or plug-in equipment.

DOME LIGHTS. White-lensed, 12 V dc lights powered from external source. Separately switched and fused.

EXHAUST FAN. Plug-in fan. Separately fused.

FLUORESCENT CEILING LAMPS. Two-level (high/low) overhead lights with blackout override switches.

EMERGENCY LIGHTS. Battery powered. Activated by power loss.

AIR CONDITIONER/HEATER. Air conditioner and electrical heater powered by three-phase, 208 V, 30 amp current.

BLACKOUT LIGHTS. Red-lensed, 12 V ac lights actuated when blackout switch operates.

POWER CABLES. Power input (120/208 V ac and 12 V dc).

1-3.3 Wiring Diagram. A foldout wiring diagram is provided at the end of this manual.

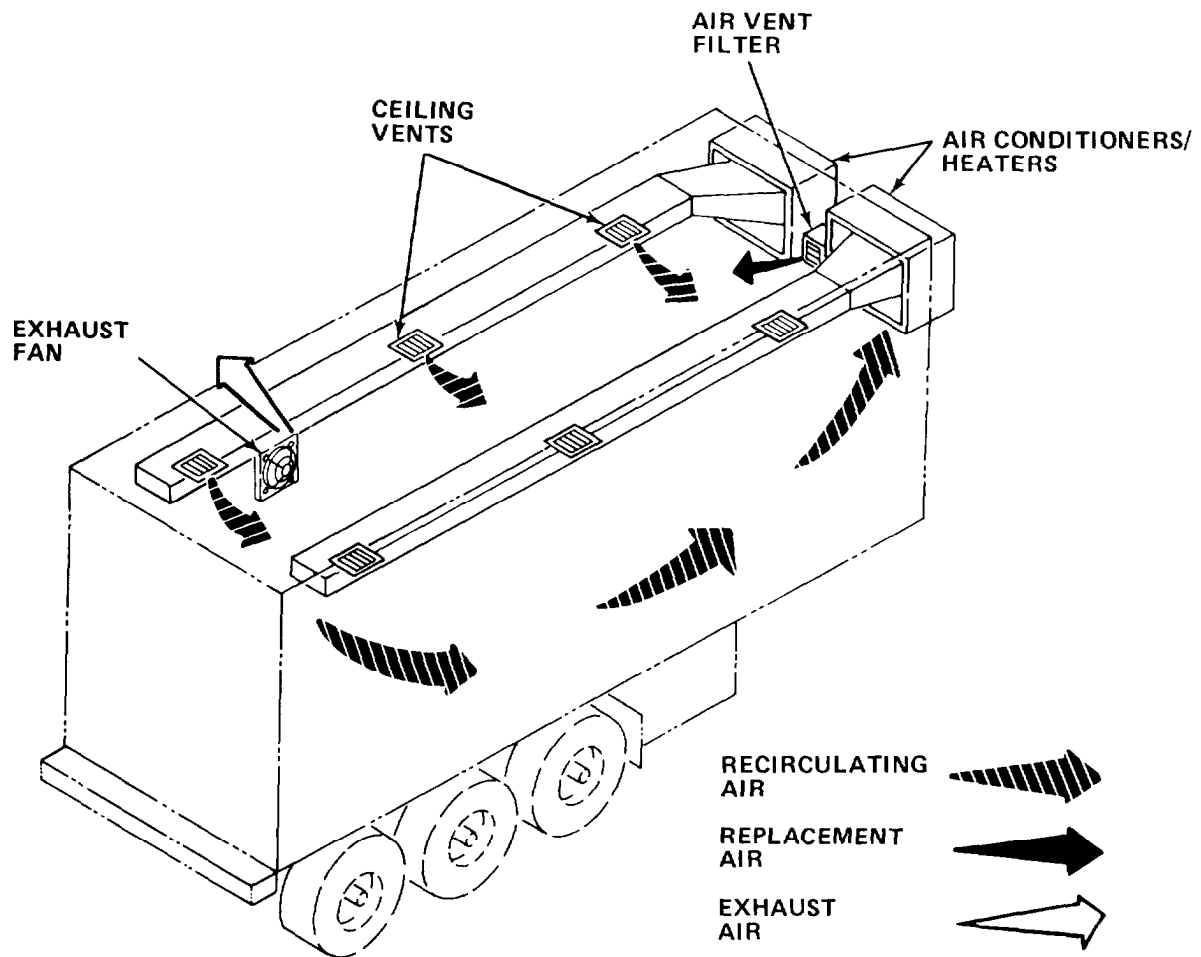

1-3.4 Ventilation System.

Exhaust fan exhausts air. Replacement air flows into the section through the air vent filter. Recirculating air is filtered as it enters the air conditioners/heaters. From the air conditioners/heaters, it flows through the ceiling vents and into the section.

**NOTE**

Detailed description of an air conditioner/heater operation is contained in TM 5-4120-367-14, Operator, Organizational, Direct Support, and General Support Maintenance Manual, Air Conditioner, Horizontal, Compact, 18,000 Btu/hr Cooling, and TM 5-4120-367-24P, Organizational, Direct Support, and General Support Maintenance Repair Parts and Special Tools List (Including Depot Maintenance Repair) for Air Conditioner, Horizontal, Compact, 18,000 Btu/hr (5274W).

Section II OPERATING INSTRUCTIONS

1-4. DESCRIPTION AND USE OF OPERATOR'S CONTROLS AND INDICATORS.

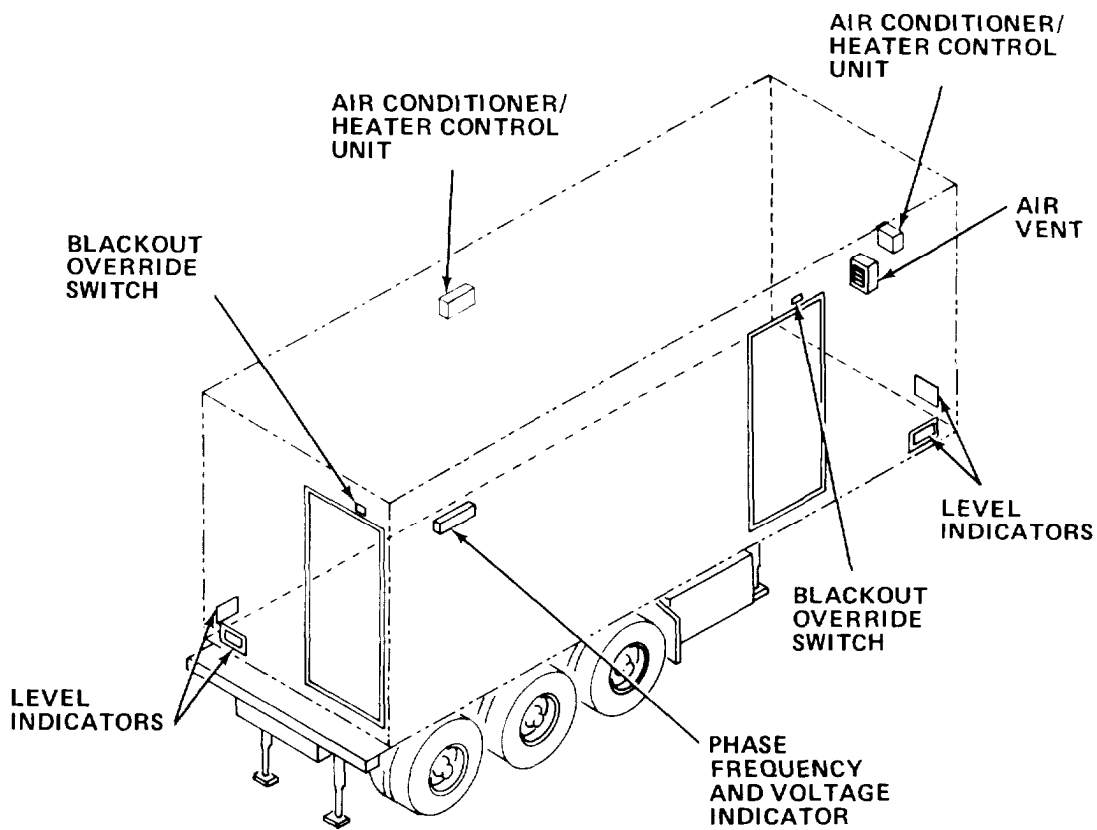

Control or Indicator	Function
Blackout Override Switches	Turn off illumination when doors are opened.
Air Vent	Permits make-up air to enter as required.
Air Conditioner/Heater Control Unit	Permits selection of air conditioner or heater mode of operation and temperature.
Phase, Frequency, and Voltage Indicator	Monitors electrical power, phase, frequency, and voltage.
Level Indicators	Used to level section.

**1-5. OPERATOR PREVENTIVE MAINTENANCE CHECKS AND SERVICES.**

- a. Before You Operate. Always keep in mind the WARNINGS and CAUTIONS. Perform your before (B) PMCS.
- b. While You Operate. Always keep in mind the WARNINGS and CAUTIONS. Perform your during (D) PMCS.
- c. After You Operate. Be sure to perform your after (A) PMCS.
- d. If Your Equipment Fails to Operate. Troubleshoot with proper equipment. Report any deficiencies using the proper forms. See DA Pam 738-750.

**1-5.1 PMCS Procedures.**

- a. PMCS are designed to keep the equipment in good working condition by performing periodic service tasks.
- b. Service intervals provide you, the operator, with time schedules that determine when to perform specified service tasks.
- c. The "Equipment is Not Ready/Available If" column is used for identification of conditions that make the equipment not ready/available for readiness reporting purposes or denies use of the equipment until corrective maintenance is performed.
- d. If your equipment fails to operate after PMCS is performed, immediately report this condition to your supervisor.
- e. Perform weekly as well as before operation if you are the assigned operator and have not operated the item since the last weekly or if you are operating the item for the first time.
- f. Item number column. Item numbers are assigned in chronological ascending sequence regardless of interval designation. These numbers are used for your "TM Number" column on DA Form 2404, Equipment Inspection and Maintenance Worksheet in recording results of PMCS.
- g. Interval columns. This column determines the time period designated to perform your PMCS.
- h. Item to be inspected and procedures column. This column lists functional groups and their respective assemblies and subassemblies as shown in the Maintenance Allocation Chart (Appendix B). The appropriate check or service procedure follows the specific item to be inspected.

i. Equipment is not ready/available if: column. This column indicates the reason or cause why your equipment is not ready/available to perform its primary mission.

j. List of tools and materials required for PMCS is as follows:

<u>Item</u>	<u>Quantity</u>
Wire Brush	1 ea
6 in. Adjustable Wrench	1 ea
Flat Tip Screwdriver	1 ea
Vacuum Cleaner	1 ea
Cheesecloth (Item 5, Appendix E)	ar
General Purpose Detergent (Item 7, Appendix E)	ar
Paint (Item 11, Appendix E)	ar
Paint Brushes	ar

Table 1-1. OPERATOR PREVENTIVE MAINTENANCE CHECKS AND SERVICES

NOTE

If the equipment must be kept in continuous operation, check and service only those items that can be checked and serviced without disturbing operation. Make the complete checks and services when the equipment can be shut down.

B - Before  
D - During  
A - After

W - Weekly  
M - Monthly  
Q - Quarterly

AN - Annually  
S - Semiannually  
BI - Biennially

(Number) - Hundreds of Hours

ITEM NO.	INTERVAL	ITEM TO BE INSPECTED  PROCEDURE	For Readiness Reporting, Equipment Is Not Ready/ Available If:
1	B/W	<p><u>VAN BODY</u></p> <p><u>Inspect Exterior.</u></p> <p>1. Inspect surfaces for punctures, cracks, or open seams that could permit moisture to enter wall.</p> 	Punctures, cracks, or open seams are present.
	B	<p>2. Inspect four level indicators for damage and to check that section is level.</p>	Indicators are broken.

Table 1-1. OPERATOR PREVENTIVE MAINTENANCE CHECKS AND SERVICES - Cont

B - Before  
D - During  
A - After

W - Weekly  
M - Monthly  
Q - Quarterly

AN - Annually  
S - Semiannually  
BI - Biennially

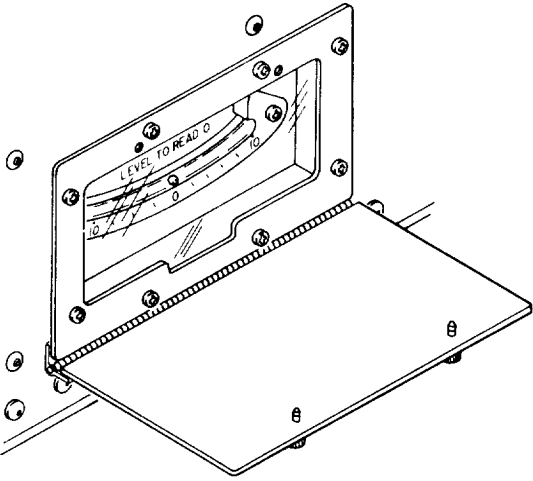
(Number) - Hundreds of Hours

ITEM NO.	INTERVAL	ITEM TO BE INSPECTED  PROCEDURE	For Readiness Reporting, Equipment Is Not Ready/ Available If:
1		<p><b><u>VAN BODY - Cont</u></b></p> <p><u>Inspect Exterior - Cont</u></p> <p style="text-align: center;"><b>WARNING</b></p> <p>To prevent death or serious injury, do not handle or clean power cable or connectors when cable is connected to power source.</p> <p>B 3. Inspect power cable assembly for dirt or damaged connectors.</p> <p>a. Wipe cable insulation with clean, dry cloth to remove dirt.</p> <p>b. Clean corrosion from terminals.</p> <div style="text-align: center;">  </div>	Connector damaged.

Table 1-1. OPERATOR PREVENTIVE MAINTENANCE CHECKS AND SERVICES - Cont

B - Before  
D - During  
A - After

W - Weekly  
M - Monthly  
Q - Quarterly

AN - Annually  
S - Semiannually  
BI - Biennially

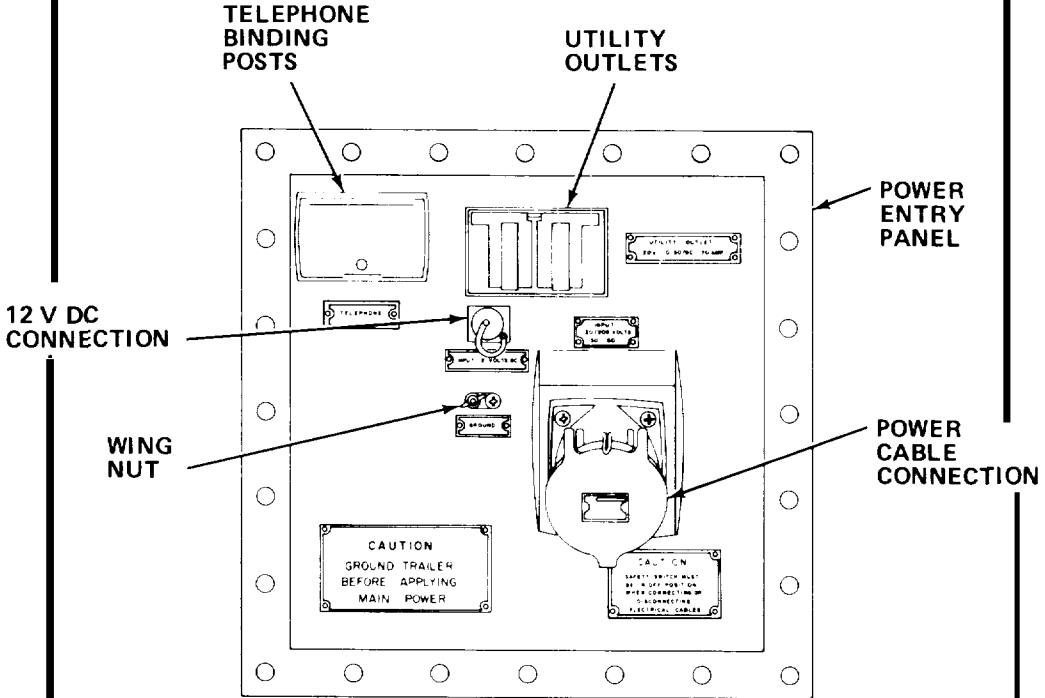
(Number) - Hundreds of Hours

ITEM NO.	INTERVAL	ITEM TO BE INSPECTED  PROCEDURE	For Readiness Reporting, Equipment Is Not Ready/ Available If:
1		<b><u>VAN BODY - Cont</u></b>	Missing covers.
	BW	<p data-bbox="337 554 711 583"><b><u>Inspect Exterior - Cont</u></b></p> <p data-bbox="354 617 1170 674">4. Inspect power entry panel for accumulated dirt, water, or corrosion.</p> <p data-bbox="418 709 802 739">Clean power entry panel.</p>	
	BW	<p data-bbox="354 777 1170 833">5. Inspect power entry panel to be sure any unused receptacles are covered.</p> <div data-bbox="431 905 1101 1482" style="text-align: center;"> <p>The diagram shows a side view of a van body with a power entry panel. Two drain tubes are shown extending from the panel. One tube is labeled 'DRAIN TUBES' and the other is labeled 'DRAIN TUBE CONNECTION'. The tubes are shown connected to a drainage system below the panel.</p> </div>	
BW	<p data-bbox="362 1596 1182 1717">6. Inspect air conditioner/heater drain tube to be sure tube is positioned as shown. Check for breaks and crimps in hose; check connections for damage or leakage.</p>		

Table 1-1. OPERATOR PREVENTIVE MAINTENANCE CHECKS AND SERVICES - Cont

B Before  
D During  
A After

W - Weekly  
M - Monthly  
Q - Quarterly

AN - Annually  
S - Semiannually  
BI - Biennially

(Number) - Hundreds of Hours

ITEM NO.	INTERVAL	ITEM TO BE INSPECTED  PROCEDURE	For Readiness Reporting, Equipment Is Not Ready/ Available If:
1		<u>VAN BODY - Cont</u>	
		<p data-bbox="285 549 654 580"><u>Inspect Exterior - Cont</u></p> <div data-bbox="404 670 1120 1372" style="text-align: center;"> <p data-bbox="999 734 1120 804">EXHAUST FAN COVER</p> <p data-bbox="817 1244 905 1315">AIR VENT COVER</p> </div> <p data-bbox="203 1500 244 1527">B/W</p> <p data-bbox="310 1500 1191 1623">7. Inspect exhaust fan cover and air vent covers to be sure they are not blocked or clogged. Clean as required. Clean screen with vacuum cleaner as necessary.</p> <p data-bbox="203 1659 244 1687">B/W</p> <p data-bbox="310 1659 1113 1751">8. Visually inspect ground connections to be sure ground cable is connected to terminal lug and ground rod. If necessary, clean:</p>	<p data-bbox="1245 1659 1389 1815">Ground connections are broken or missing.</p>



Table 1-1. OPERATOR PREVENTIVE MAINTENANCE CHECKS AND SERVICES - Cont

		B - Before D - During A - After	W - Weekly M - Monthly Q - Quarterly	AN - Annually S - Semiannually BI - Biennially	(Number) - Hundreds of Hours	
ITEM NO.	INTERVAL	ITEM TO BE INSPECTED			PROCEDURE	For Readiness Reporting, Equipment Is Not Ready/ Available If:
1		<u>VAN BODY - Cont</u>				
		<u>Inspect Exterior - Cont</u>				
		<u><b>WARNING</b></u>				
		Electrical shock hazard. Power cable must be deenergized before servicing entry panel connections. Death can result from failure to observe these safety precautions.				
		a. Turn power off to power cable. Disconnect from power source.				
		b. Disconnect ground lug from ground rod.				
		c. Clean lug, cable end, and rod with wire brush.				
		d. Reconnect ground cable lug to rod.				
		e. Disconnect ground cable end from entry panel.				
		f. Clean terminal and cable end with wire brush.				
		g. Reconnect ground cable to entry panel.				
		h. Reconnect power cable to power source. Turn power on.				
	B	9. Inspect boarding ladders for:				
		a. Secure attachment of handrails.				
		b. Steps not broken.				
		c. Locking pins in place.				
						Steps are broken or will not lock in place.

Table 1-1. OPERATOR PREVENTIVE MAINTENANCE CHECKS AND SERVICES - Cont

B - Before  
D - During  
A - After

W - Weekly  
M - Monthly  
Q - Quarterly

AN - Annually  
S - Semiannually  
BI - Biennially

(Number) - Hundreds of Hours

ITEM NO.	INTERVAL	ITEM TO BE INSPECTED  PROCEDURE	For Readiness Reporting, Equipment Is Not Ready/ Available If:
<b><u>VAN BODY - Cont</u></b>			
1		<u>Inspect Exterior - Cont</u>	
		<b>NOTE</b>	
		When mounted on trailer chassis, perform the following steps.	
	B/ D/A	10. Inspect front and rear van body locks to be sure locks are fully engaged.	Lock dis-engaged.
	Q	11. Inspect gaskets on personnel doors for leaks or damage.	
	W	11.1 Inspect, hinges for proper placement of hinge pins.	Missing hinge pins.
	Q	12. Clean and paint blistered, pitted, or flaking areas and bare metal spots in accordance with instructions contained in TM 43-0139, Painting Instructions for Field Use.	
2		<u>Inspect Interior.</u>	
	B/D	1. Test emergency lights by pressing test button.	Emergency lights do not light.
	W	2. Inspect power cords and cables to be sure wires are not kinked, cut, or cracked.	Wires or cables are cracked or cut .
	W	3. Inspect plug connectors to be sure all plug connectors are tight and firmly seated. Tighten if necessary.	
	D	4. Inspect for burned out light bulbs and fluoresce lamps. Replace as required.	
	W	5. Inspect walls, ceiling, and floor for holes, open seams, or signs of seepage or leaks.	Leaks are present.

Table 1-1. OPERATOR PREVENTIVE MAINTENANCE CHECKS AND SERVICES - Cont

B - Before  
D - During  
A - After

W - Weekly  
M - Monthly  
Q - Quarterly

AN - Annually  
S - Semiannually  
BI - Biennially

(Number) - Hundreds of Hours

ITEM NO.	INTERVAL	ITEM TO BE INSPECTED	PROCEDURE	For Readiness Reporting, Equipment Is Not Ready/ Available If:
<u>VAN BODY - Cont</u>				
2	<u>Inspect Interior - Cont</u>			
	D	6. Check storage cabinets for broken hinges, latches, and locks.		Hinge, latch, or lock is broken.
	B/ M/A	7. Inspect fire extinguishers. Be sure security seals are not broken.		Fire extinguisher is missing or seals are broken.
	Q	8. Inspect circuit breaker panel.		Circuit breaker is defective.
<b>NOTE</b>				
Inspection is to be conducted on a not-to-interfere basis with work being conducted. Individual equipment will be inspected as directed by the appropriate chapter of this manual.				

Table 1-1. OPERATOR PREVENTIVE MAINTENANCE CHECKS AND SERVICES - Cont

B - Before  
D - During  
A - After

W - Weekly  
M - Monthly  
Q - Quarterly

AN - Annually  
S - Semiannually  
BI - Biennially

(Number) - Hundreds of Hours

ITEM NO.	INTERVAL	ITEM TO BE INSPECTED  PROCEDURE	For Readiness Reporting, Equipment Is Not Ready/ Available If:
2		<p><u>VAN BODY - Cont</u></p> <p><u>Inspect Interior - Cont</u></p>  <p>a. Set main circuit breaker to ON.</p> <p>b. Set each circuit breaker to OFF, then ON.</p> <p>Q 9. Inspect light traps.</p>	

Table 1-1. OPERATOR PREVENTIVE MAINTENANCE CHECKS AND SERVICES - Cont

B - Before  
D - During  
A - After

W - Weekly  
M - Monthly  
Q - Quarterly

AN - Annually  
S - Semiannually  
BI - Biennially

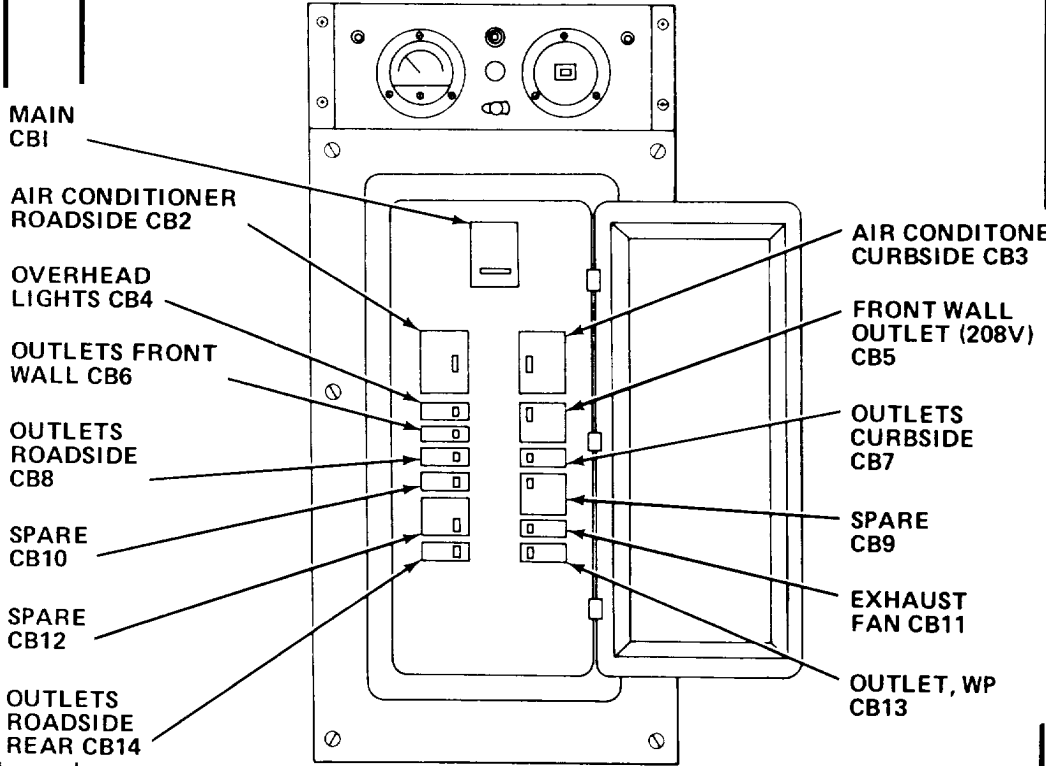
(Number) - Hundreds of Hours

ITEM NO.	IN-TERVAL	ITEM TO BE INSPECTED	PROCEDURE	For Readiness Reporting, Equipment Is Not Ready/ Available If:
2	A	<u>VAN BODY - Cont</u>  <u>Inspect Interior - Cont</u>	<ul style="list-style-type: none"> <li>a. Turn on fluorescent lamps (high level).</li> <li>b. Close entrance doors. Have exhaust fan and air vent open. Inspect for light leakage through vents.</li> <li>c. Place light switches ON; blackout override switches OFF.</li> <li>d. Open door and make sure internal lights go off.</li> </ul> <p>10. Inspect/clean interior.</p>	<p>Light leaks are present.</p> <p>Blackout system is inoperable.</p>
		<b><u>WARNING</u></b>		
		<p>Death or serious injury may occur if wet or damp cloth is used to wipe or clean energized equipment, power cords, or cables.</p>		
		<b><u>CAUTION</u></b>		
		<p>Do not sweep interior. Dislodged dirt or dust will ruin optical, electronic, and photographic equipment and supplies.</p>		

Table 1-1. OPERATOR PREVENTIVE MAINTENANCE CHECKS AND SERVICES - Cont

B - Before  
D - During  
A - After

W - Weekly  
M - Monthly  
Q - Quarterly

AN - Annually  
S - Semiannually  
BI - Biennially

(Number) - Hundreds of Hours

ITEM NO	INTERVAL	ITEM TO BE INSPECTED	PROCEDURE	For Readiness Reporting, Equipment Is Not Ready/ Available If:
---------	----------	----------------------	-----------	--

2

**VAN BODY - Cont**

**Inspect Interior - Cont**

- a. Wipe vertical and horizontal painted surfaces with cleaning cloth moistened with solution of general purpose detergent and fresh water until soil is removed from painted surfaces.
- b. Dry vertical and horizontal painted surfaces with clean cloth.
- c. Vacuum interior of section to remove dirt and waste. Pay particular attention to work stations.

S 11. Inspect first aid kit.

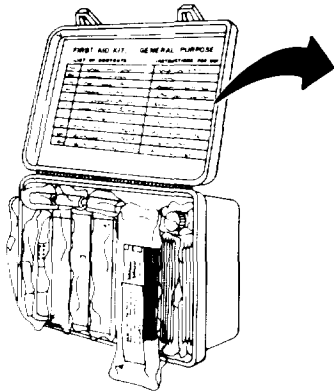

FIRST AID KIT, GENERAL PURPOSE		
LIST OF CONTENTS	INSTRUCTIONS FOR USE	
1 ROLL	ADHESIVE TAPE (SINGLE 1 1/2" ROLLS)	USE FOR MUD, LOTS AND TO TRIM WOUND
12 EACH	BAND-AID ADHESIVE 4 X 3"	MINOR CUTS AS REQUIRED
2 EACH	BAND-AID GAUZE (COMPRESSED) CAMOUFLAGED 2 X 6" PADS	CUT IN LENGTHS AS REQUIRED FOR BAND-AID WOUNDS
1 EACH	BAND-AID MUSLIN (COMPRESSED) CAMOUFLAGED 8" X 8" (10" X 10")	USE FOR BLEEDS
1 PKG.	BLADE (SURGICAL PREPARATION RAZOR) STRAIGHT SINGLE EDGE #2	SHAVING HAIR AND OPENING WOUNDS AS REQUIRED
1 PKG.	COMPRESS AND BAND-AID (CAMOUFLAGED) 2 X 4" IN	FOR WOUNDS
1 EACH	CREOSOTE (FIRST AID) OIL AND WAXES	FOR WOUND WOUNDS EXTENSIVE BURNING
1 EACH	FIRST AID KIT EYE WASHING	FOR EYE WOUNDS SEE INSTRUCTIONS
1 PKG.	GAUZE (POLYMER) 2 X 4" IN	FOR WOUNDS APPLY GAD OVER WOUND
1 BTL.	HYDROXY TISSUE SOLUTION (1 OZ) IN 1	NO INDENTIONS AND CLEAN WITH IT AND WOUNDS APPLY BEFORE BANDING
1 EACH	AMMONIA (INVALENT)	TOUCH AMMONIA BETWEEN FINGERS HOLD A FEW MOMENTS FROM NOSE HOLD TISSUE AS AMMONIA DRIES REPEAT WHEN YOU FEEL FRESH AMMONIA
1 EACH	INSTRUCTION BOOKLET AND FIRST AID EXPLANATIONS	

- a. Remove first aid kit from bracket.
- b. Remove contents.
- c. Inspect container for damage.

Table 1-1. OPERATOR PREVENTIVE MAINTENANCE CHECKS AND SERVICES - Cont

ITEM NO.	IN-TERVAL	ITEM TO BE INSPECTED  PROCEDURE	For Readiness Reporting, Equipment Is Not Ready/ Available If:
2	B/W	<p><u>VAN BODY - Cont</u></p> <p><u>Inspect Interior - Cont</u></p> <p>d. Inspect contents for damage. Then use checklist to inventory contents.</p> <p>e. Replace damaged or missing items.</p> <p>f. Repack kit.</p> <p>g. Reinstall kit.</p> <p>12. Inspect blackout curtains.</p> <p>a. Inspect blackout curtains and valances for tears, missing hooks, or broken eyelets.</p> <p>b. Inspect nylon hook and pile tape on curtain. and wall for security of attachment.</p>	Curtains damaged.
3	B	<p><u>Inspect Air Conditioner/Heater.</u> Refer to TM 5-4120-367-14 for preventive maintenance checks and services.</p>	
4	M	<p><u>Service Power Cable.</u></p> <p style="text-align: center;"><u><b>WARNING</b></u></p> <p>Electrical shock hazard. Power cable must be deenergized before servicing. Death or serious injury may occur from failure to observe this safety precaution.</p>	

Table 1-1. OPERATOR PREVENTIVE MAINTENANCE CHECKS AND SERVICES - Cont

B - Before  
D - During  
A - After

W - Weekly  
M - Monthly  
Q - Quarterly

AN - Annually  
S - Semiannually  
BI - Biennially

(Number) - Hundreds of Hours

ITEM NO.	INTERVAL	ITEM TO BE INSPECTED	For Readiness Reporting, Equipment Is Not Ready/ Available If:
4	M	<p><u>VAN BODY - Cont</u></p> <p><u>Service Power Cable - Cont</u></p> <ol style="list-style-type: none"> <li>1. Turn off safety switch.</li> <li>2. Disconnect cable from power entry panel.</li> <li>3. Wrap any cuts or abrasions in cable with electrical insulation tape.</li> </ol> <p style="text-align: center;"><b>NOTE</b></p> <p style="text-align: center;">Check to be sure cable does not endanger personnel.</p> <ol style="list-style-type: none"> <li>4. Reconnect power cable to entry panel.</li> </ol>	

**1-6. OPERATION UNDER USUAL CONDITIONS.** Operation of Collection Section consists of activation of power after the section has been located at the operation site and 12 V dc power disconnected.

1-6.1 Preparation for Use.

- a. Procedures for leveling.

**CAUTION**

Trailer-mounted section must be on surface that is approximately level to avoid unnecessary stress or twisting of chassis when section is leveled.



## NOTE

- Snow or ice should be removed from under leveling foot plate before attempting to level section.
- Sand, soft ground, or mud requires that shoring or scrap material be placed under leveling foot plate to increase surface area and prevent sinking into surface.
- Be sure that air suspension is deflated as indicated in TM 5-2330-305-14.

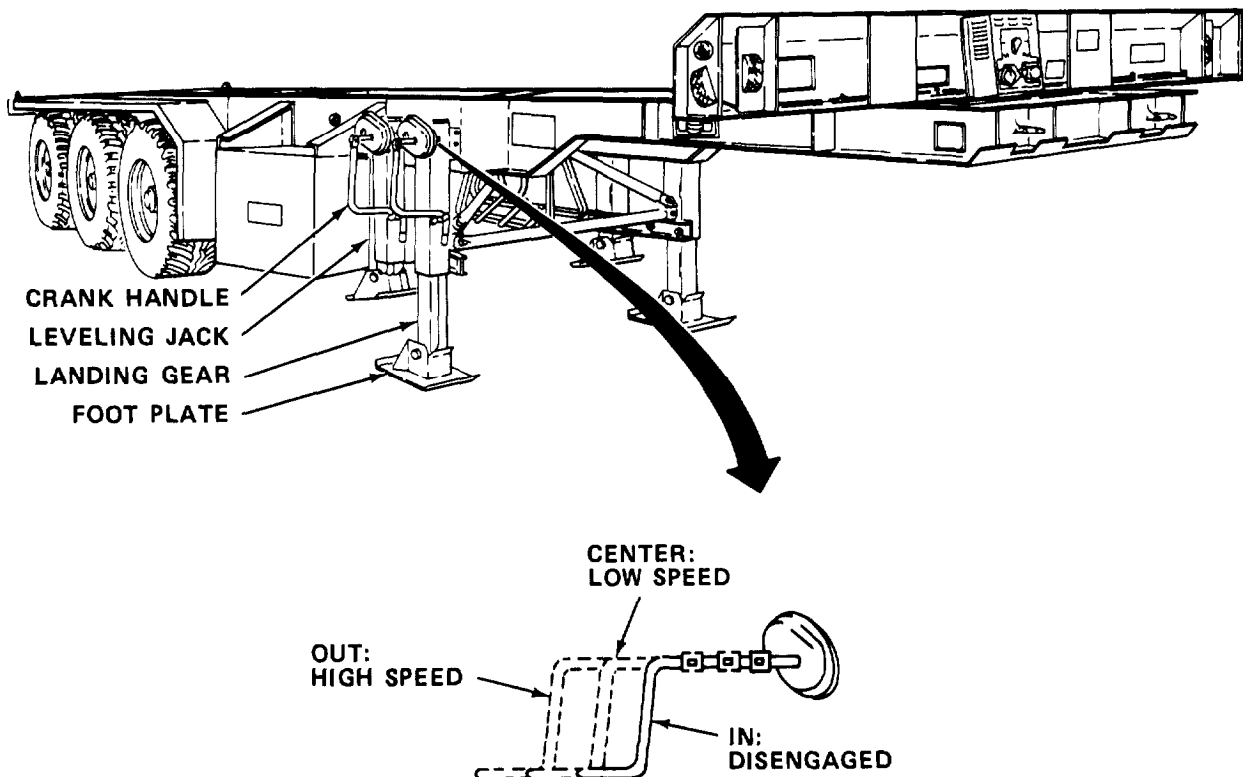

- (1) Deflate air suspension in accordance with TM 5-2330-305-14.
- (2) Approximately level trailer chassis by raising or lowering landing gear.
- (3) Move handle from secured location and swing out.
- (4) Pull crank handle on each leveling jack all the way out and engage. There are two positions when handle is engaged. Fully out is high speed. partially out is low speed.
- (5) Lower each leveling jack by turning crank to right at high speed until foot plate just contacts ground.

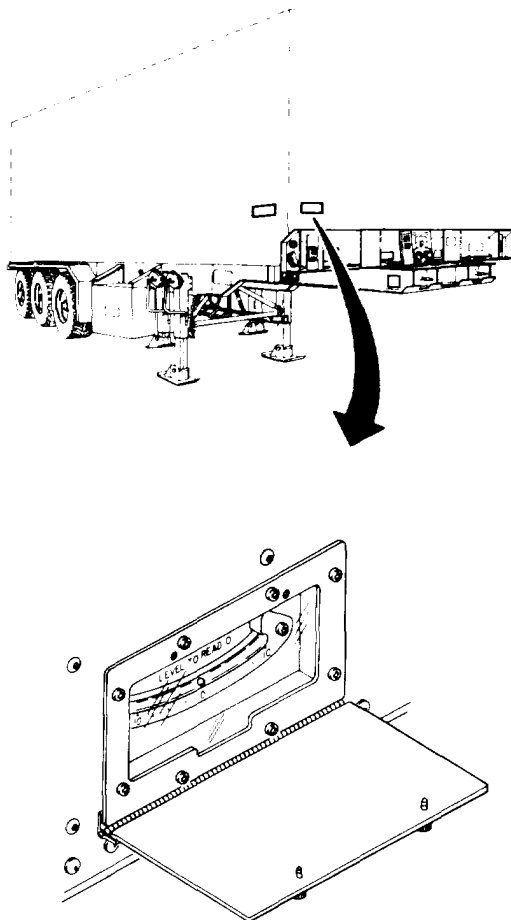

(6) Station personnel to have a clear view of level indicators at both front and rear of section.

(7) Observe level indicators to determine which end and side must be raised.

**CAUTION**

Do not attempt to level section by lifting at diagonal corners, or frame will be twisted.

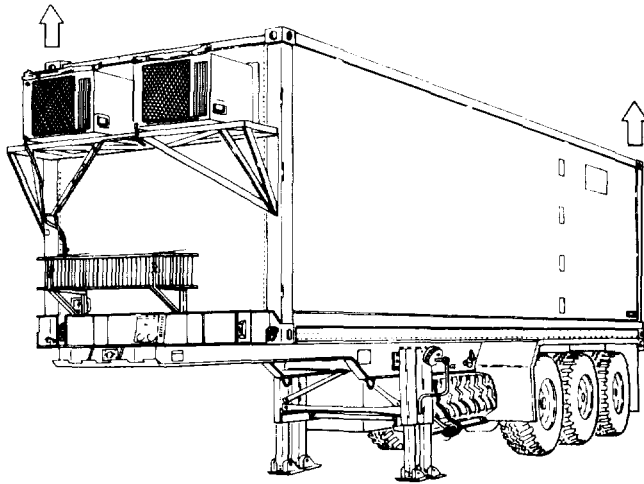

NO

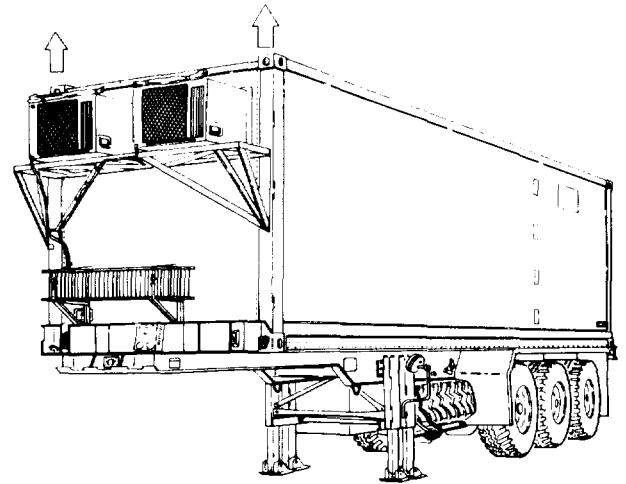

YES

(8) Raise low end by extending both leveling jacks at low end. Use low speed.

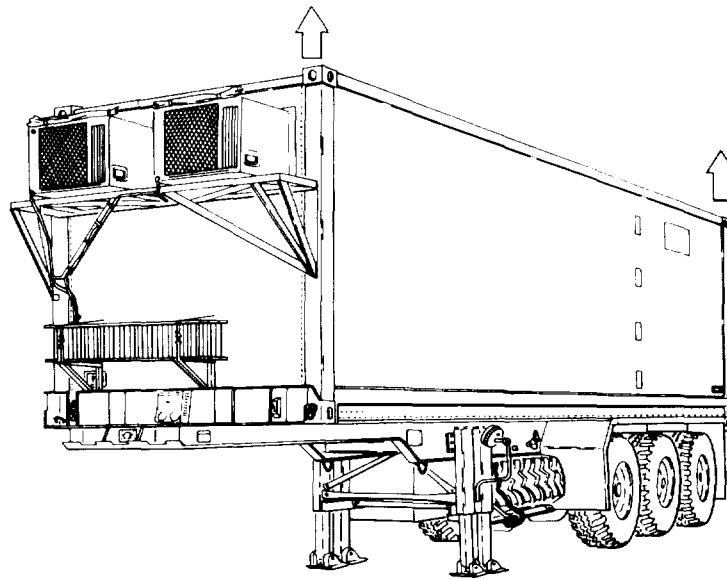

(9) Raise low side by extending both leveling jacks at low side.

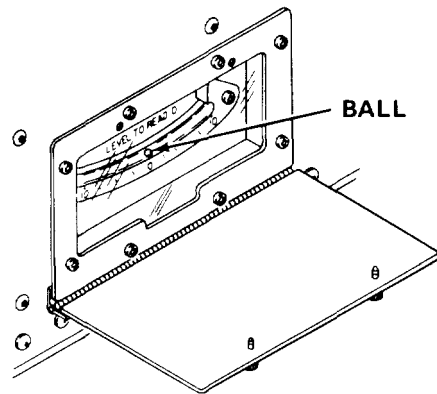

**NOTE**

Be sure ball is centered on all four level indicators  $\pm 2^\circ$ .

(10) Pull leveling crank handles away from trailer chassis, and lower crank handle to stowed position.

b. Procedures to activate section.

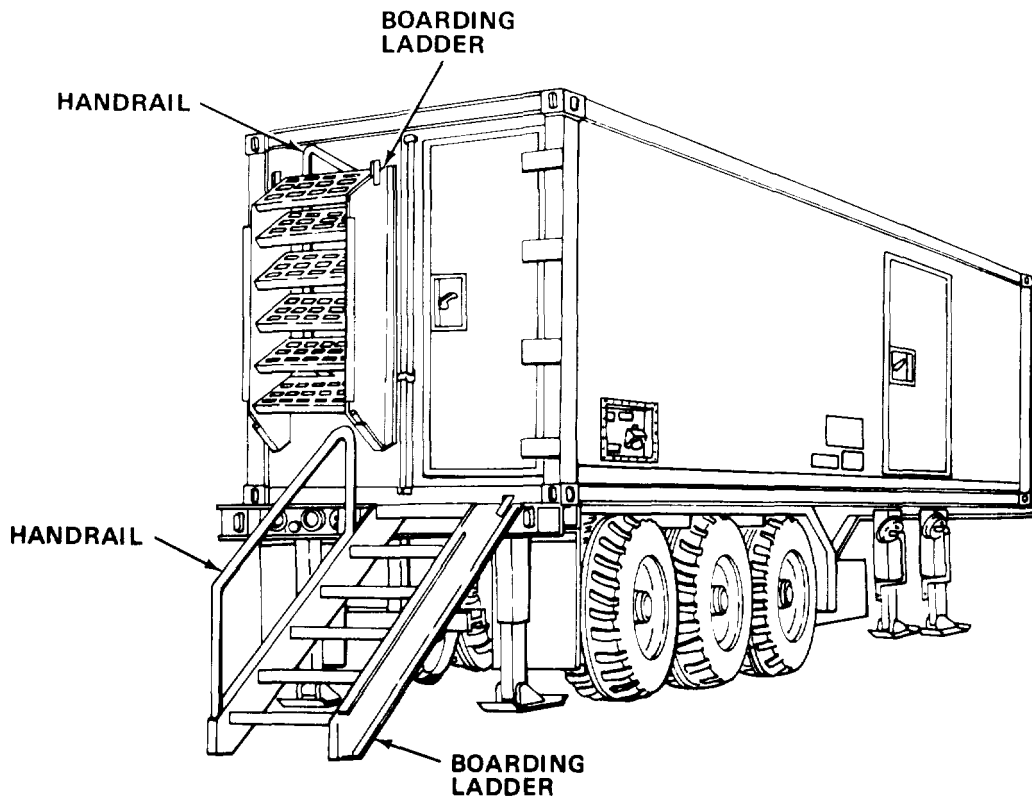

- (1) Remove boarding ladders and handrails from rear of section.
- (2) Remove handrails from ladders.

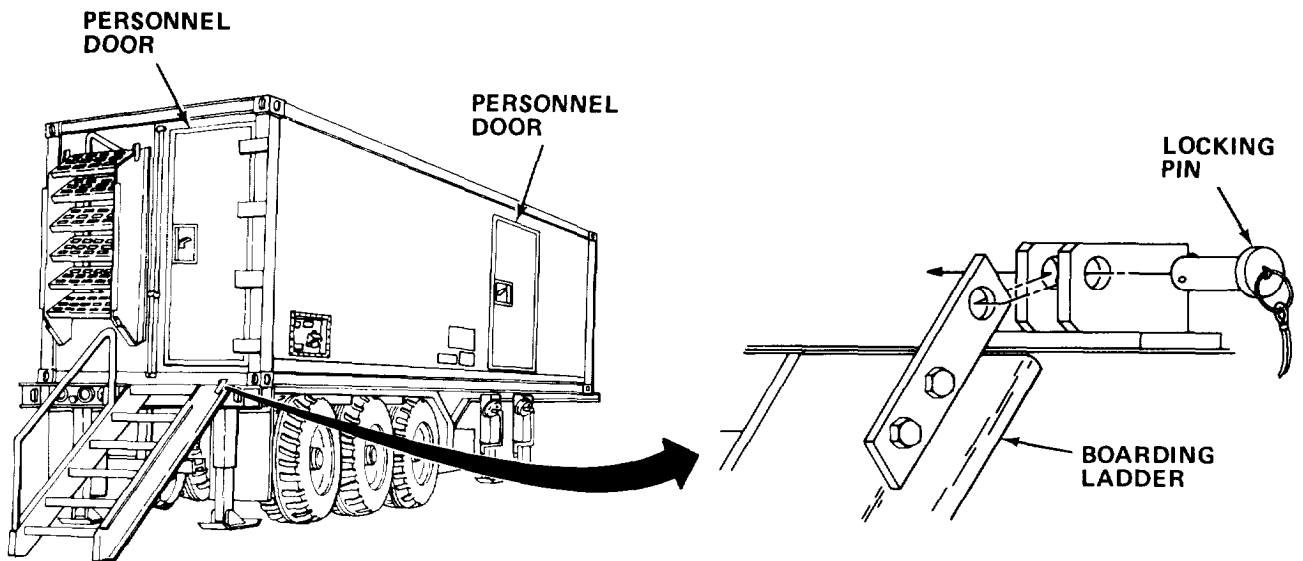

- (3) Mount ladders at personnel doors and secure with locking pins.

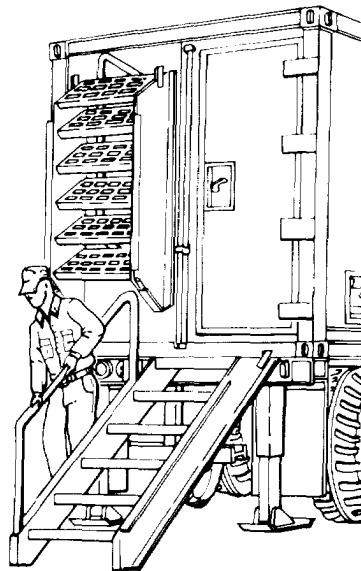

- (4) Mount one handrail on each ladder.
- (5) Enter section and be sure safety switch, main circuit breaker, and all equipment power supply switches are off.

**WARNING**

Death or serious injury may result from connecting power cable to section before grounding.

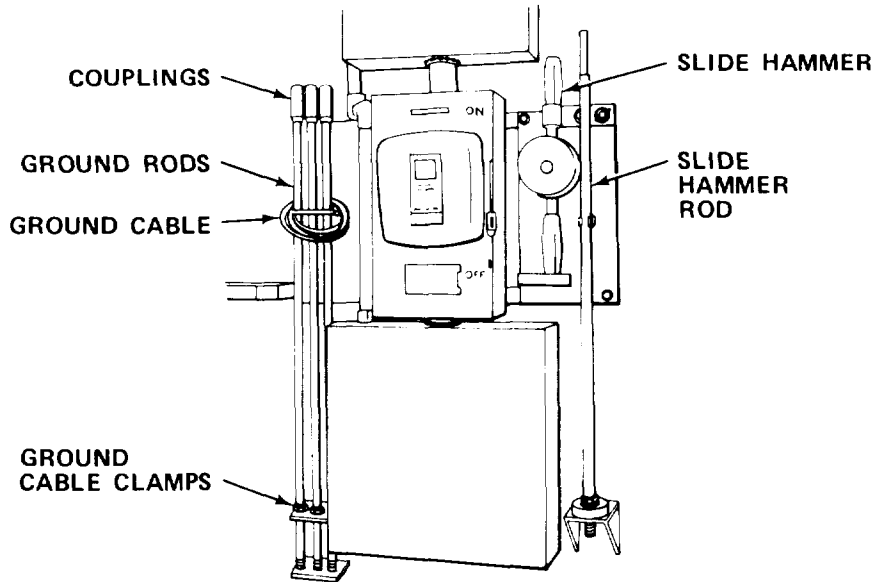

(6) Remove ground rod, slide hammer, and ground cable from section.

**NOTE**

- Apply a thin film of grease to threaded ends of rods before driving into ground. This will permit easy disassembly upon removal from ground.
- Bottom ground rod must be numbered or identified so that it will always be the first rod driven into the ground.
- These instructions supplement TC 11-6, Grounding Techniques.

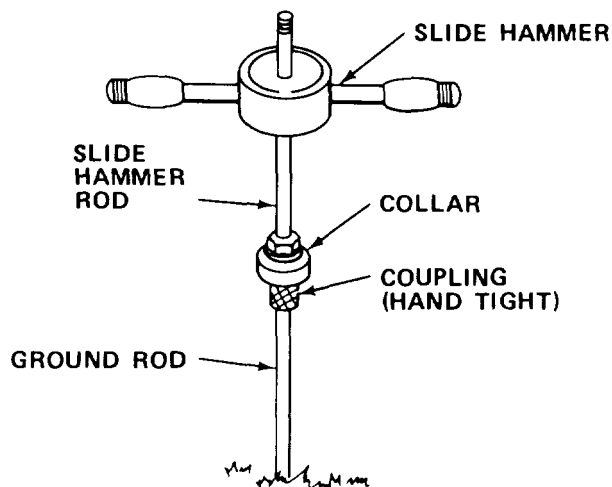

(7) Select an area as close to power entry panel as possible to install ground rod. Then assemble the first ground rod and coupling to the slide hammer rod.

**CAUTION**

Do not allow ground rod to rotate when removing the slide hammer rod. Rods must be kept screwed together to make a good electrical ground.

**NOTE**

Before driving ground rod be certain that rods meet inside coupling. Be sure collar is handtight against coupling.

(8) Place slide hammer on hammer rod end and drive ground rod into ground. Remove slide hammer rod. Attach slide hammer rod to a new section of ground rod, and repeat procedure until only 12 in. (30.5 cm) of the third rod is above ground.

(9) Remove slide hammer and hammer rod and place in section.

(10) Secure ground cable clamp and ground cable to ground rod.

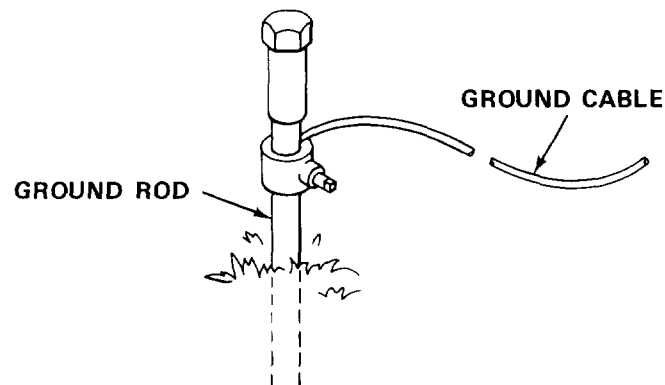

**WARNING**

To prevent death or serious injury, do not handle or clean power cable or connectors when cable is connected to power source.

**NOTE**

The section must be properly grounded before power is connected. If it is not possible to drive the three sections of ground rod fully into ground, the rods may each be driven into the ground separately and connected in series. If it is impossible to drive a ground rod, a suitable alternative ground must be found, such as a buried metal water pipe. See TC 11-6, Grounding Techniques for additional instructions.

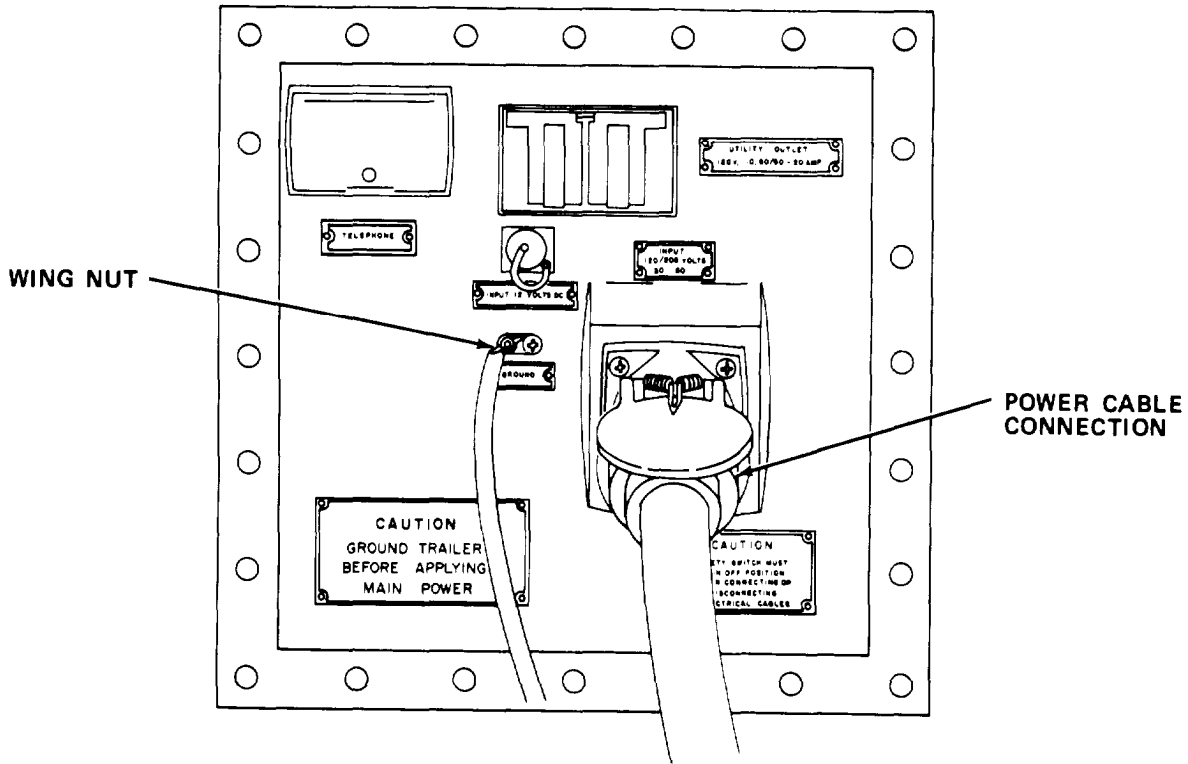

(11) Connect ground cable to ground lug with wing nut.

**CAUTION**

Be sure safety switch is off before connecting power cable to avoid equipment damage.

(12) Firmly connect the power cable to the power receptacle.



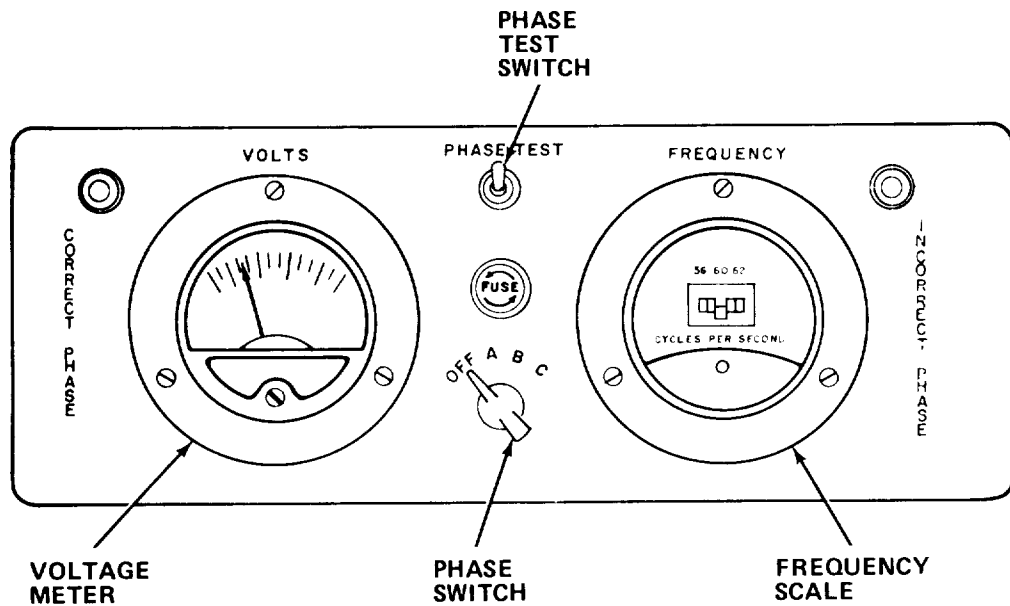

(13) Turn on safety switch.

#### **CAUTION**

Do not energize section if incorrect phase lamp lights. Damage to equipment may result.

(14) Check voltage and frequency as follows:

- (a) Push phase test switch. Observe correct phase lamp lights.
- (b) Turn phase switch to A.

#### **CAUTION**

Voltage must be between 110 and 120 and frequency must be at  $60 \pm 1$  Hz on each leg before turning on main circuit breaker or damage to equipment may result.

- (c) Read voltage on meter.
- (d) Read frequency on scale.
- (e) Repeat for positions B and C on phase switch.

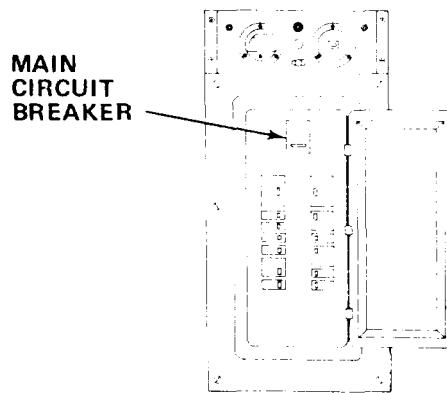

(15) Set main circuit breaker ON.

**NOTE**

This step must be accomplished if section is placed in operation in darkness, fog, mist, or under blackout conditions.

(16) Close blackout curtains, if required.

(17) Turn on circuit breakers in following order:

- (a) Individual lighting.
- (b) Curbside and roadside air conditioners/heaters.
- (c) Curbside and roadside receptacles.

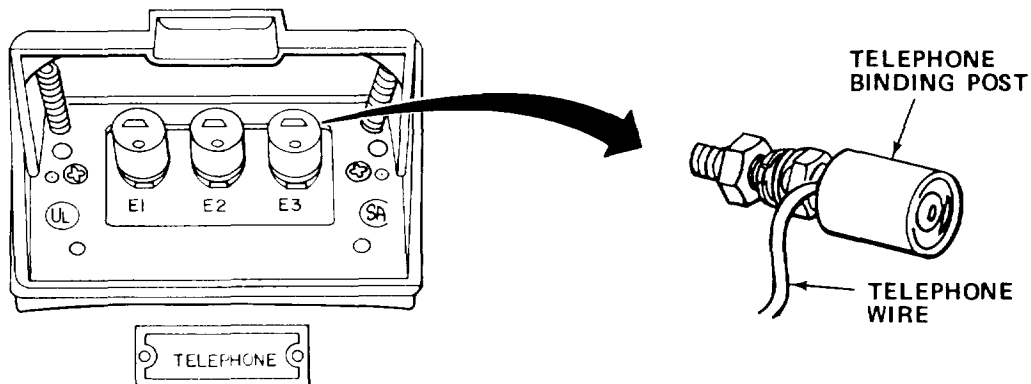

(18) Connect telephone lines to corresponding interior binding posts.

(19) Check blackout switches.

(20) Plug in emergency lighting and turn switch to READY.

1-6.2 Preparation for Movement.

a. Inventory equipment and supplies.

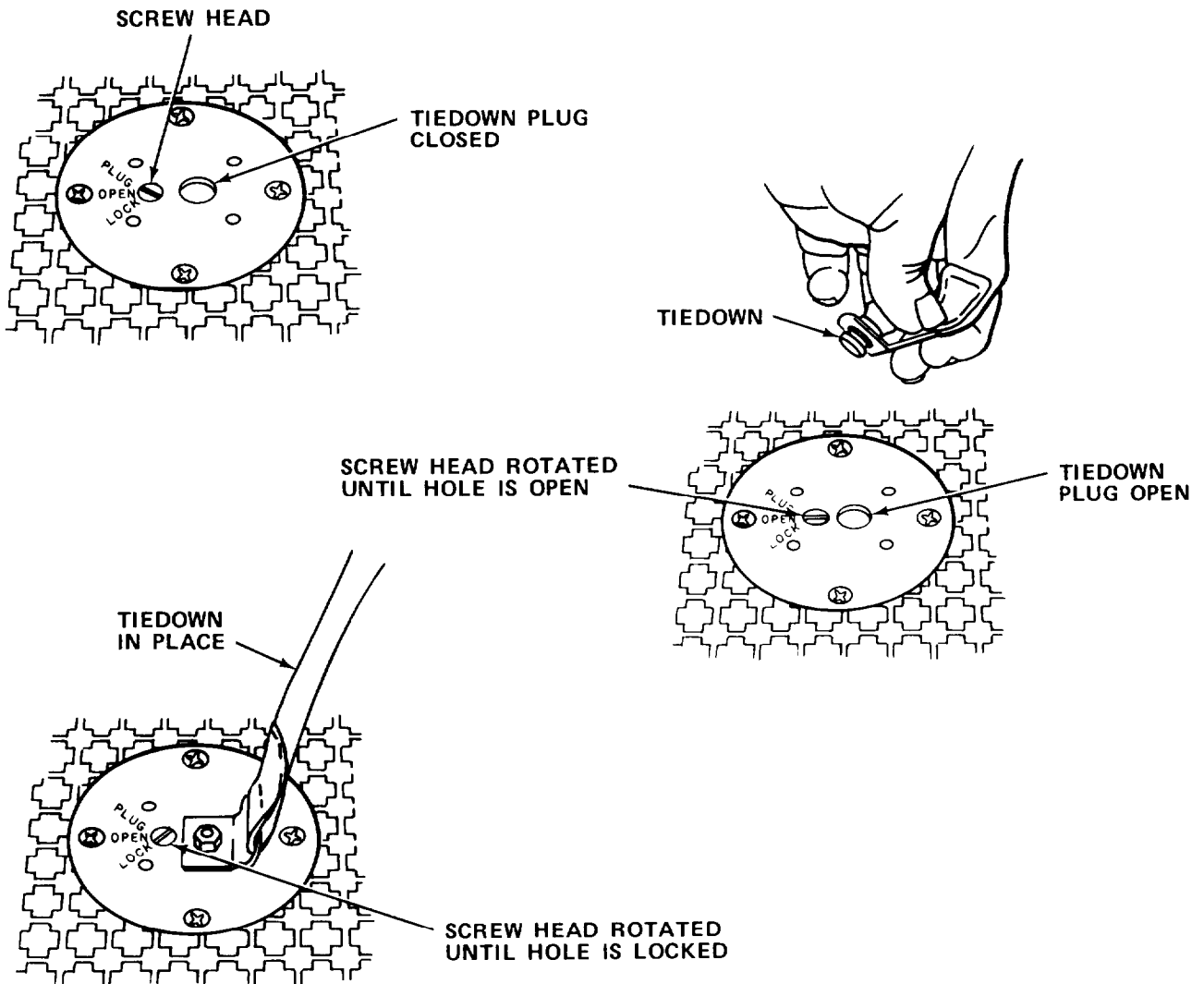

b. Install tiedowns in tiedown sockets.

c. Secure authorized equipment in proper containers or as specified by appropriate chapters.

d. Secure straps and remove slack from tiedowns.

**WARNING**

Death or serious injury may occur if power cable is disconnected while power is on.

- e. Turn equipment switches OFF.
- f. Turn main circuit breaker OFF.
- g. Turn safety switch OFF.
- h. Have power cable disconnected at power supply end. Then disconnect power cable from receptacle. Put cable in storage box on trailer chassis.
- i. Turn emergency light switch OFF.
- j. Disconnect telephone cables from power entry panel.

**CAUTION**

To prevent loss of rod or thread damage, do not allow ground rod to rotate and unscrew when removing the slide hammer rod.

- k. Remove ground rod with slide hammer and put ground rods, couplings, and slide hammer inside section. Clean threads on each ground rod before storing.

**NOTE**

Be certain exhaust fan and air vent doors are securely closed.

- l. Reinspect section interior for loose equipment and close all vents.
- m. Close section. Secure and lock all personnel doors and cargo door.

**NOTE**

Be sure air conditioner/heater covers are down and secured.

- n. Remove handrails from boarding ladders.
- o. Remove boarding ladders and insert handrails into back of ladders.
- p. Secure ladders to back of section.
- q. Fully extend landing gear.
- r. Retract leveling jacks.
- s. Visually inspect section exterior to be sure all equipment and covers are secured.

1-6.3 Operating Instructions on Decals and Instruction Plates.

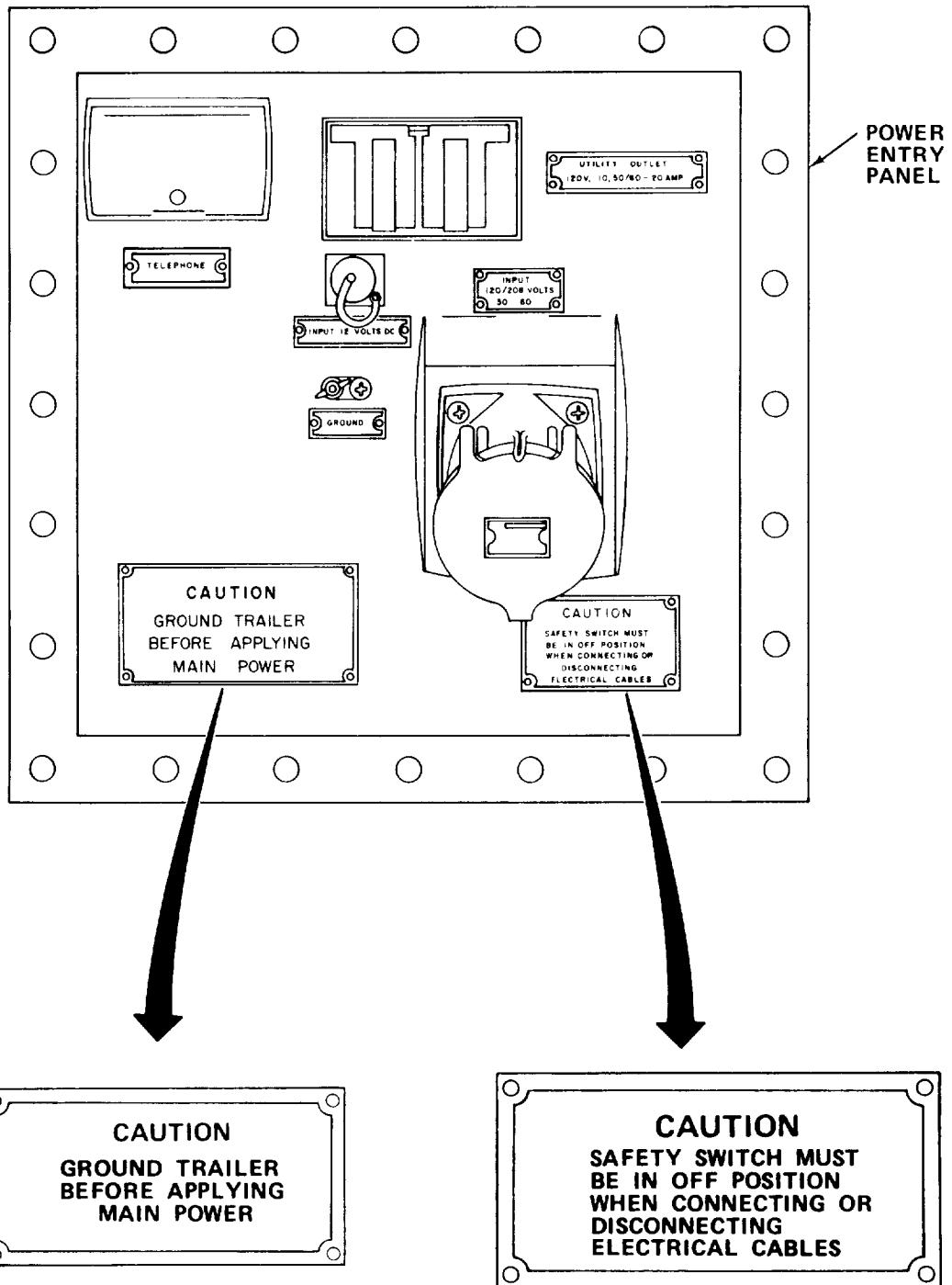

**CAUTION**  
FOR SAFE OPERATION  
SEE TM FOR PROPER  
INTERNAL AND EXTERNAL  
GROUNDING

**CAUTION TO START UNIT ON "COOL"  
MODE AT 0°F AMBIENT  
JUMPER LACO SWITCH (S-5)**

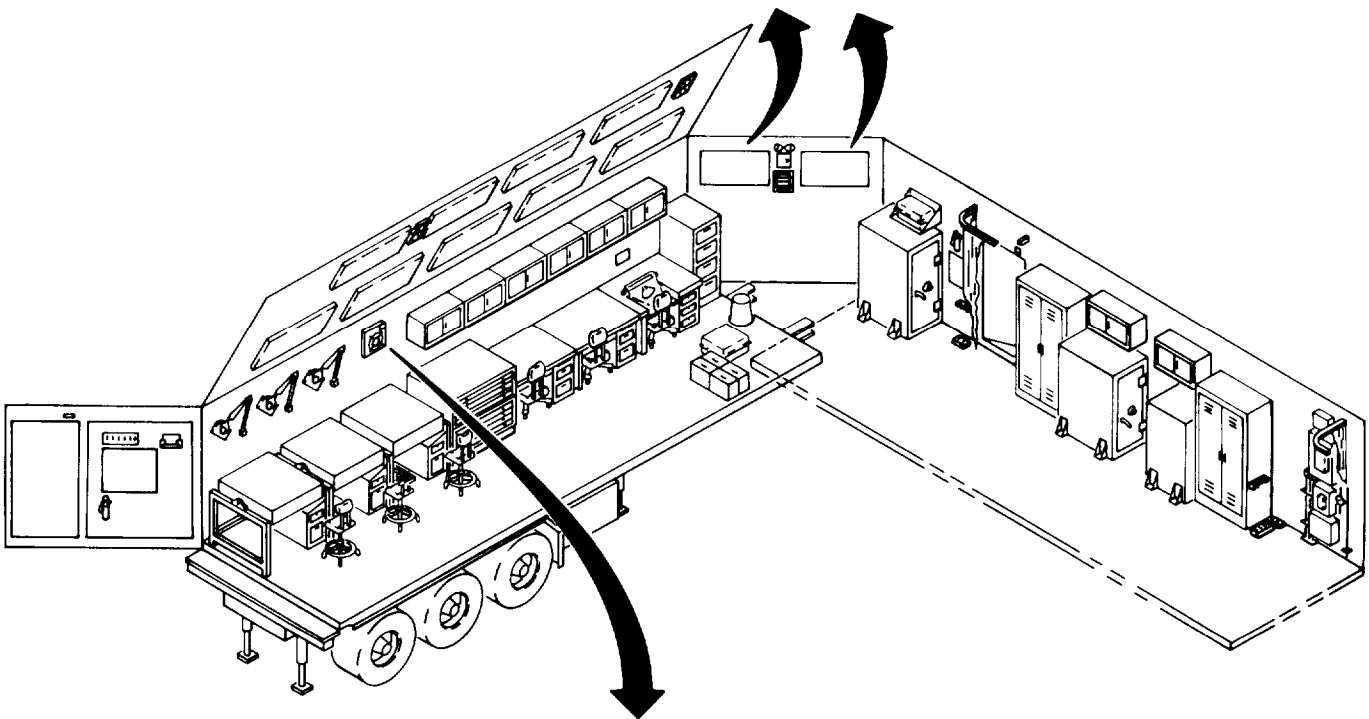

**CAUTION**

OPEN OUTSIDE VENT BEFORE  
OPERATING FAN

**CAUTION**  
EMERGENCY LIGHT SWITCH  
MUST BE IN THE OFF POSITION  
WHEN ELECTRICAL POWER  
IS INTENTIONALLY DISCONNECTED  
  
SWITCH MUST BE IN THE READY  
POSITION FOR NORMAL EMERGENCY  
LIGHT OPERATION

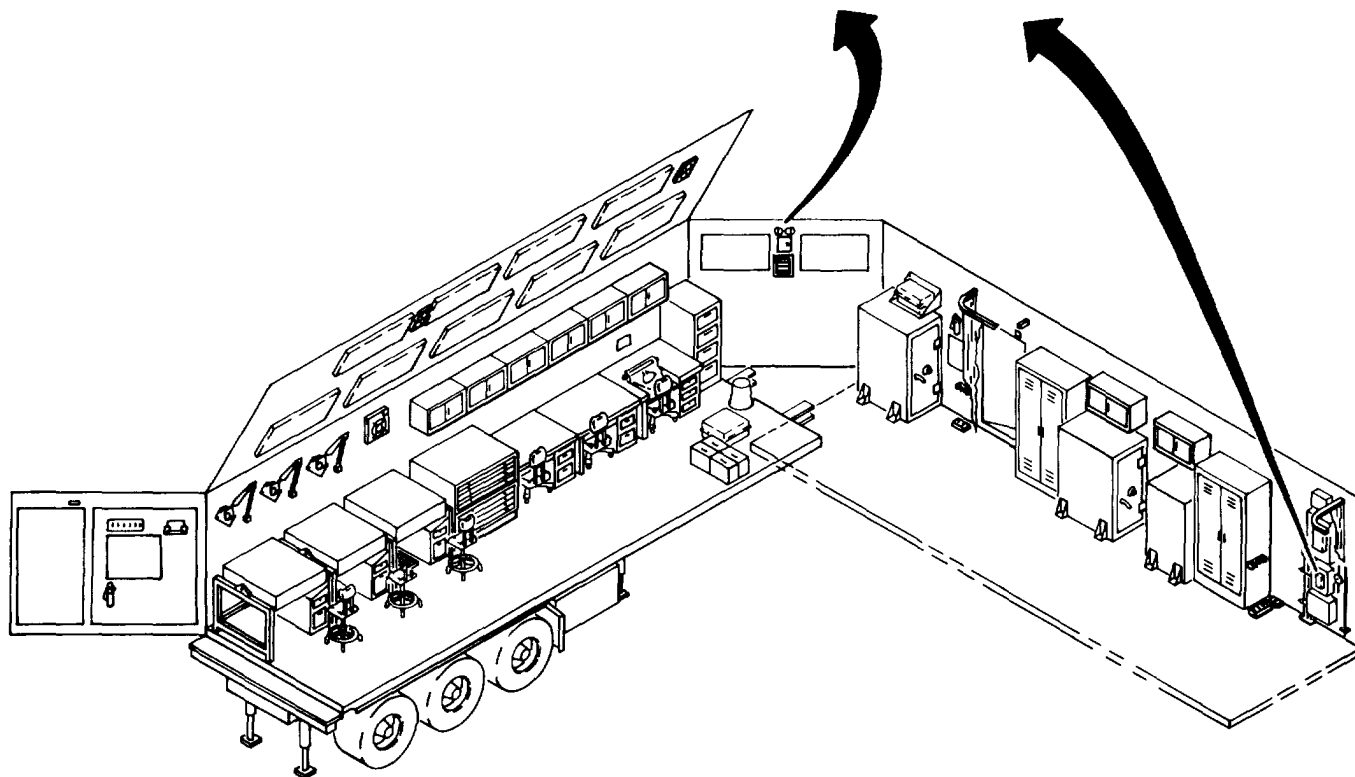

**CAUTION**  
OPEN OUTSIDE FLAPS  
PRIOR  
TO OPERATING AIR COND

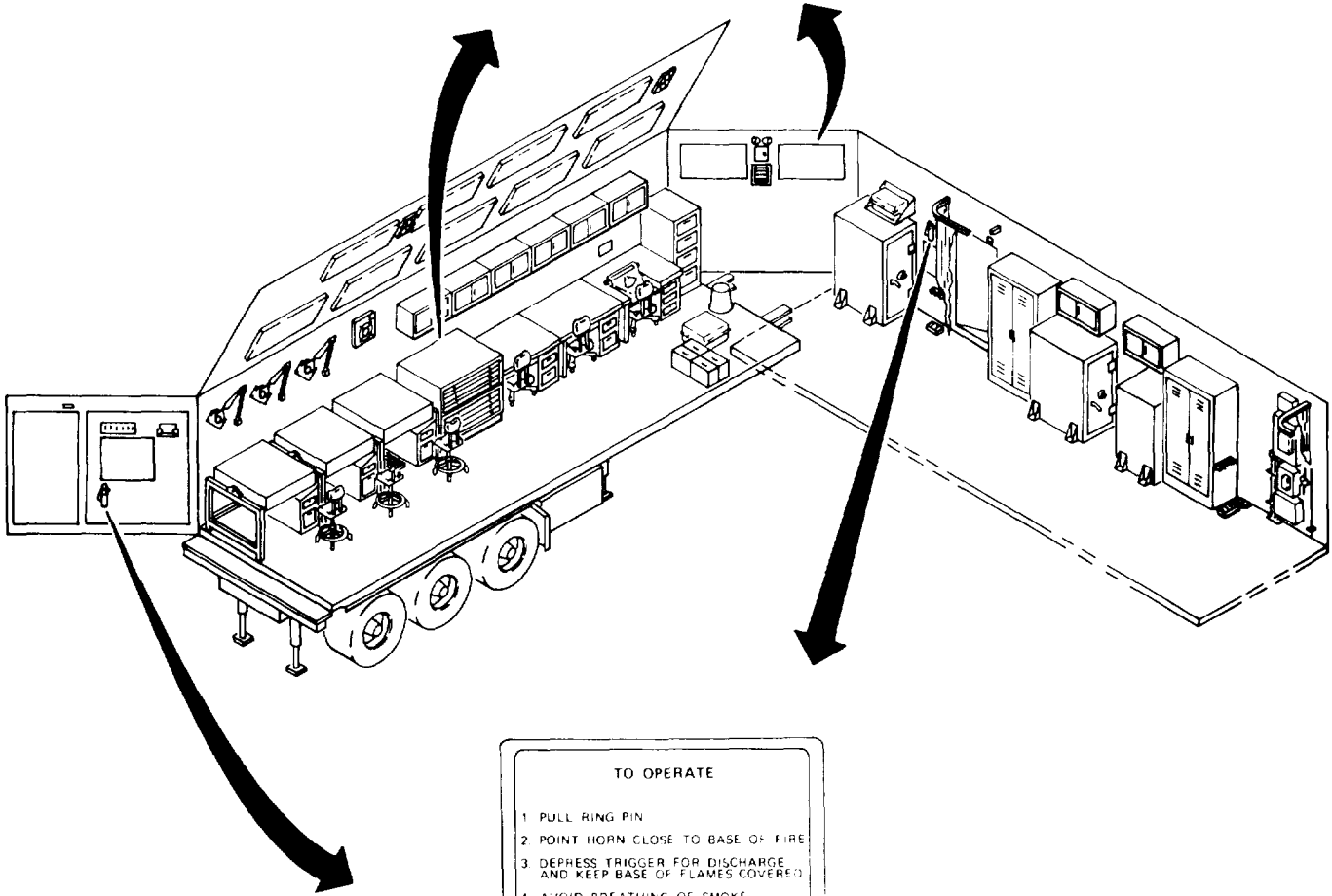

**TO OPERATE**

- 1 PULL RING PIN
- 2 POINT HORN CLOSE TO BASE OF FIRE
- 3 DEPRESS TRIGGER FOR DISCHARGE AND KEEP BASE OF FLAMES COVERED
- 4 AVOID BREATHING OF SMOKE
- 5 REMOVE VALVE AND HORN ASSEMBLY AND DISCARD USED CYLINDER

EXTINGUISHER, FIRE, CF<sub>3</sub>BR, 2 3/4 LB



**1-7. OPERATION UNDER UNUSUAL CONDITIONS.****NOTE**

Damage to container permitting light leaks, water, or dirt entry must be temporarily repaired using available material on hand. Maintenance personnel will conduct permanent repairs; however, crew must maintain operational capability of section.

**1-7.1 Operation in High Wind or Storm Conditions.**

- a. Relocate section if trees or structures present hazard.

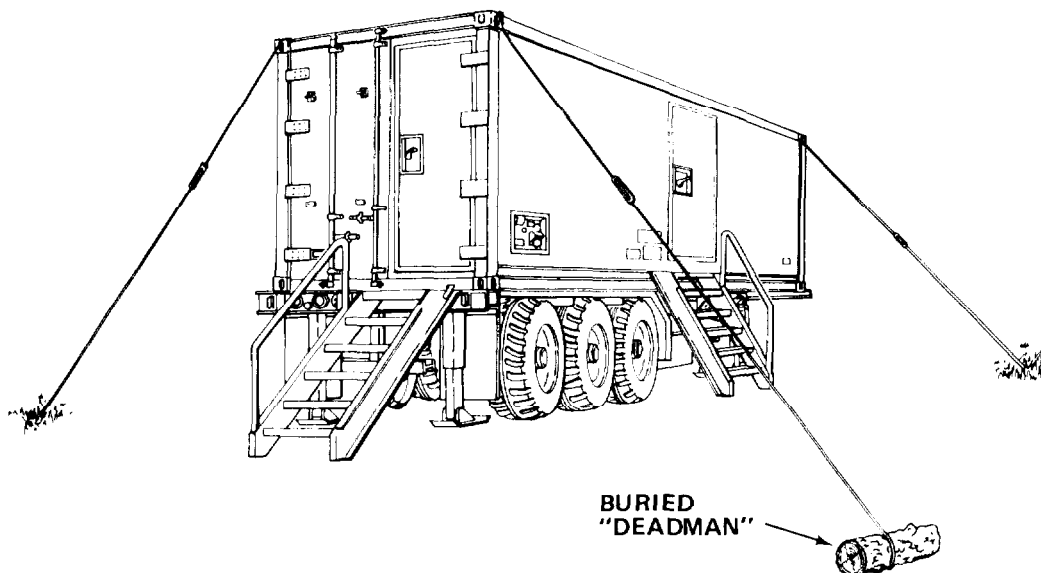
**SUGGESTED METHOD OF ANCHORING THE SECTION IN HIGH WINDS**

- b. Secure section corners at lifting eyes to deadmen or substantial objects.
- c. Remove all loose objects from area.

**1-7.2 Operation in Cold Weather.**

a. The operation of the internal equipment is performed within environmentally controlled conditions; however, in extreme cold, the main power supply cable and ground cable will become hard, brittle, and difficult to handle. Be careful when connecting or disconnecting the cables so that kinks and unnecessary loops will not result in permanent damage.

b. Make certain that connections and cable receptacles on the outside of the section are free of frost, snow, and ice.

c. When section heaters are not operating or when the section is being transported, liquid consumable supplies may freeze, break their containers, then melt, and ruin equipment or documents. Store these items in an area to prevent equipment and document damage.

1-7.3 Operation in Extreme Heat. The operation of the internal equipment is performed within environmentally controlled conditions; however, during transportation or when air conditioning units are not operating, consumable supplies may suffer reduced shelf life, and internal components may have accelerated deterioration of gaskets, seals, or insulation.

1-7.4 Operation in Tropical Conditions. Fungi, mildew, or mold will form on and in equipment, documents, and supplies if internal environmental control equipment is not operating and outside heat and humidity are allowed to enter the section.

1-7.5 Operation in Desert Conditions. Dust, grit, and sand will ruin supplies, equipment, and documents. Extreme care must be taken to prevent dust, grit, and sand from entering the section. Air filters will be changed whenever airflow is restricted, and cleaning of section interior must be conducted more frequently than specified by PMCS schedules.

1-7.6 Emergency Procedures. There are no specific emergency procedures for operation of the section.

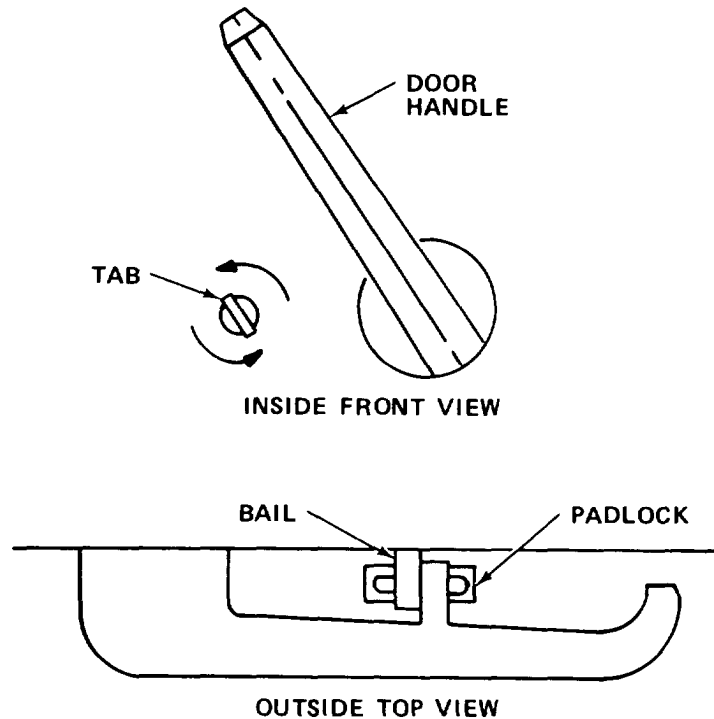

1-7.7 Emergency Means of Exit. In the event personnel are locked in the section, the tab may be turned to the left until the bail on the padlock falls free. The door handle is now free to turn.

### Section III OPERATOR MAINTENANCE

#### 1-8. LUBRICATION INSTRUCTIONS.

a. Lubrication instructions for the Collection Section are contained in LO 5-6675-322-12, Lubrication Order, Collection Section, Topographic Support System. The intervals and man-hours specified in the Lubrication Order are based on normal operations. During inactive periods, lubrication periods may be extended with adequate preservation.

b. Topographic equipment and all optical equipment require special care in lubrication. When a specified lubricant is called for, substitutions are not authorized. Minimum amounts of lubricant are to be used and all excess lubricant is to be immediately removed. Spray lubricants must not be used in the vicinity of optical equipment unless optics are completely protected. No lubricant is to be applied unless a thorough cleaning is conducted first to remove dirt, dust, or abrasive material.

c. Be sure that you refer to the appropriate chapter before any equipment is stored after use, that the temperature has stabilized, and that lubrication required after use is accomplished.

#### 1-9. TROUBLESHOOTING PROCEDURES.

a. The table lists the common malfunctions which you may find during operation or maintenance of the Collection Section, or its components. You should perform the test/inspections and corrective actions in the order listed.

b. This manual cannot list all malfunctions that may occur, nor all test or inspections and corrective actions. If a malfunction is not listed or is not corrected by listed corrective actions, notify your supervisor.

Table 1-2. TROUBLESHOOTING

MALFUNCTION

TEST OR INSPECTION

CORRECTIVE ACTION

## 1. NO ELECTRICAL POWER TO SECTION.

**WARNING**

Death or serious injury may result. Do not perform any electrical maintenance or make electrical connections or disconnections at main power receptacle when power cable is energized.

Step 1. Observe voltage and frequency for phases A, B, and C. Read  $115 \pm 5V, 60 \pm 1 \text{ Hz}$ .

(a) If voltage and frequency are correct, proceed to step 2.

(b) If voltage and frequency are incorrect, notify power supply supervisor.

**CAUTION**

Do not energize section if voltage or frequency is not correct. Damage to equipment may result.

Step 2. Press phase test switch on power panel for A, B, and C.

(a) If phases A, B, and C are correct, proceed to step 3.

(b) If incorrect phase lamp lights, notify power supply supervisor.

**CAUTION**

Do not energize section if incorrect phase lamp lights. Damage to equipment may result.

Step 3. Check safety switch position.

(a) If safety switch is ON, proceed to step 4.

(b) If safety switch is OFF, turn ON.

Table 1-2. TROUBLESHOOTING - Cont

---

MALFUNCTION	TEST OR INSPECTION	CORRECTIVE ACTION
-------------	--------------------	-------------------

---

1. NO ELECTRICAL POWER TO SECTION - Cont
  - Step 4. Check main circuit breaker position.
    - (a) If circuit breaker is ON, refer to direct/general support maintenance.
    - (b) If circuit breaker is OFF, turn ON.
    - (c) If circuit breaker trips repeatedly, notify power supply supervisor.
2. NO ELECTRICAL POWER TO EQUIPMENT.
  - Step 1. Check equipment power switch.
    - (a) If power switch is ON, proceed to step 2.
    - (b) If power switch is OFF, turn ON.
  - Step 2. Check power cord.
    - (a) If power cord is plugged in, proceed to step 3.
    - (b) If power cord is unplugged, plug in.
  - Step 3. Inspect circuit breaker panel for breakers in OFF position.
    - (a) If all circuit breakers are ON, refer to direct/general support maintenance.
    - (b) If any circuit breakers are OFF, turn ON.

Table 1-2. TROUBLESHOOTING - Cont

MALFUNCTION

TEST OR INSPECTION

CORRECTIVE ACTION

3. BLACKOUT SWITCH DOES NOT OPERATE.

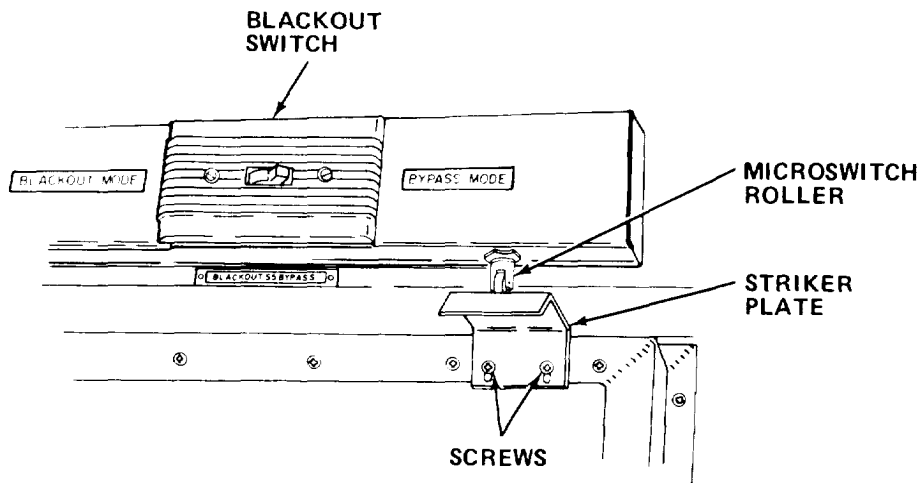

Step 1. Check blackout switch position.

- (a) If switch is ON, proceed to step 2.
- (b) If switch is OFF, reset switch to BLACKOUT.

Step 2. Check to see that striker plate contacts roller on microswitch.

- (a) Loosen screws, and move plate up or down until microswitch operates.
- (b) If blackout switch still fails to operate, refer to organizational maintenance.

**1-10. MAINTENANCE PROCEDURES.**

a. This section contains instructions covering operator maintenance functions for the Collection Section. Personnel required are listed only if the task requires more than one.

b. After completing each maintenance procedure, perform operational check to be sure that equipment is properly functioning.

**INDEX**

PROCEDURE	PARAGRAPH
Replace Fluorescent Lamp . . . . .	1-10.1
Service Ventilation Ducts . . . . .	1-10.2
Replace Blackout/Dome Light . . . . .	1-10.3

1-10.1 Replace Fluorescent Lamp.

MOS: 81Q, Terrain Analyst

TOOLS: None

SUPPLIES: Fluorescent Lamp

**WARNING**

Death or serious injury may result if power is left on while servicing lamp.

- a. Turn switch OFF.

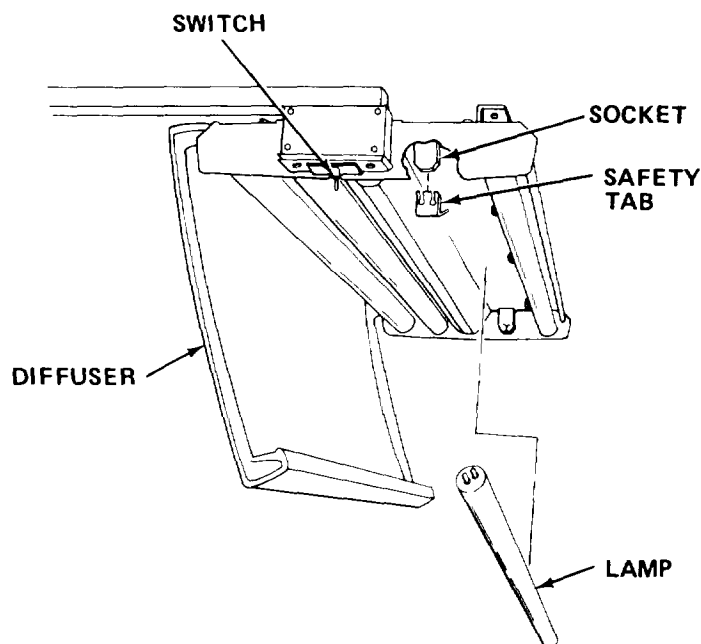

- b. Gently pull diffuser from light bracket and place diffuser out of the way to prevent damage.
- c. Remove safety tab from lamp socket.
- d. Rotate defective lamp until prongs are free from slot and remove.
- e. Insert new lamp prongs into slot and rotate 90 degrees.
- f. Reinstall safety tab into lamp socket.
- g. Reinstall diffuser.
- h. Turn power ON.



1-10.2 Service Ventilation Ducts.

MOS: 81Q, Terrain Analyst

TOOLS: Vacuum Cleaner  
Flat Tip Screwdriver

SUPPLIES: None

- a. Cover equipment to prevent dust from entering equipment.
- b. Close all doors and cabinets.
- c. Remove any documents or other work that may be damaged by dirt/dust.
- d. Turn off air conditioner/heater.

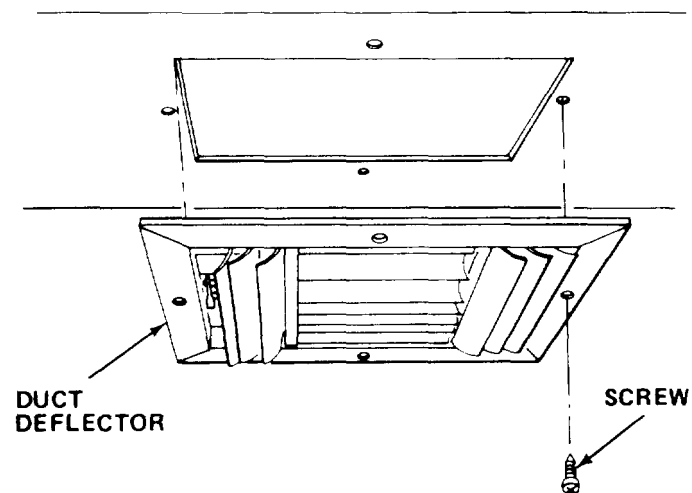

- e. Remove four screws from each ventilation duct deflector.
- f. Remove all duct deflectors.
- g. Vacuum dirt or dust from deflector louvers.
- h. Insert vacuum cleaner probe into ventilation duct at each deflector hole and vacuum as far as probe will reach.
- i. Reinstall deflectors and secure with four screws.
- j. Turn on air conditioner/heater.
- k. Vacuum any dislodged dirt or dust from interior of section.
- l. Remove covers for operation.

1-10.3 Replace Blackout/Dome Light.

MOS: 81Q, Terrain Analyst

TOOLS: None

SUPPLIES: Lamp (12 V)  
Silicone Spray (Item 20, Appendix E)

**NOTE**

Blackout light and dome light are sealed units. No bulb replacement is possible. Complete light must be replaced.

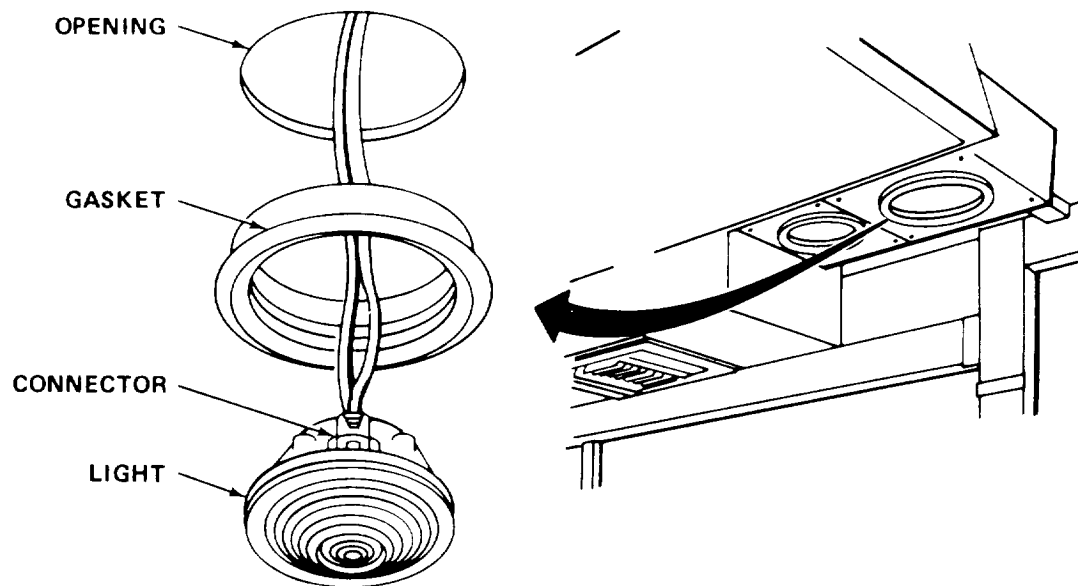

- a. Push light and gasket up into opening.
- b. Tilt and remove light and gasket from opening.
- c. Disconnect defective light from connector.
- d. Connect new light to connector.
- e. Reinstall gasket in opening.

**NOTE**

The use of silicone spray on the gasket will help to position light.

- f. Position light in gasket and push in.

## Section IV ORGANIZATIONAL MAINTENANCE

**1-11. LUBRICATION INSTRUCTIONS.** This equipment does not require lubrication at this level of maintenance.

### **1-12. REPAIR PARTS, SPECIAL TOOLS; TEST, MEASUREMENT, AND DIAGNOSTIC EQUIPMENT (TMDE); AND SUPPORT EQUIPMENT.**

1-12.1 Common Tools and Equipment. For authorized common tools and equipment, refer to the Modified Table of Organization and Equipment (MTOE) applicable to your unit.

1-12.2 Special Tools; Test, Measurement, and Diagnostic Equipment; and Support Equipment. Special Tools, TMDE, and Support Equipment is listed in the applicable repair parts and special tools list and in Appendix B of this manual.

1-12.3 Repair Parts. Repair parts for this equipment are listed in the Repair Parts and Special Tools List, TM 5-6675-322-24P covering organizational maintenance for this equipment.

### **1-13. SERVICE UPON RECEIPT.**

#### **NOTE**

The section may be received mounted on a chassis, or as a van body for mounting on an available transporter, or on site. Inspection of the chassis is covered in TM 5-2330-305-14. Inspection of the air conditioner/heater is covered in TM 5-4120-367-14.

#### 1-13.1 Checking Unpacked Equipment.

a. Inspect the equipment for damage incurred during shipment. If the equipment has been damaged, report the damage on DD Form 6, Packing Improvement Report.

(1) Visually inspect the section exterior starting at the rear to cover rear, curbside, roadside, front, top, and bottom. Inspect for damage, tears, breaks or corrosion.

(2) Enter section and inspect for broken equipment, tool boxes, chairs, or equipment loose and not secured.

(3) Close doors and vents to determine if light leaks exist.

(4) Inspect doors for damage, torn or rotted seals, and tightness of closure.

(5) Inspect interior for evidence of water damage, fungi, mildew or corrosion.

(6) Report damage or discrepancies in accordance with AR 735-11 and AR 735-11-2.

b. Check the equipment against the packing list to see if shipment is complete. Report all discrepancies in accordance with the instructions of DA Pam 738-750.

(1) Inventory section against Components of End Item and Basic Issue Items Lists (Appendix C).

(2) Inventory expendable supplies contained in section as shown in Appendix E.

(3) Conduct operational checks on equipment in accordance with the chapters in this manual when operators are available and power can be safely provided to the section.

c. Check to see whether the equipment has been modified.

#### 1-14. ORGANIZATIONAL PREVENTIVE MAINTENANCE CHECKS AND SERVICES

a. PMCS are designed to keep the equipment in good working condition by performing certain tests, inspections, and services. The intervals provide you, the organizational technician, with time schedules that determine when to perform specified tasks.

b. Item number column. Item numbers are assigned in chronological ascending sequence regardless of interval designation. These numbers are used for your "TM Number" column on DA Form 2404, Equipment Inspection and Maintenance Worksheet, in recording the results of PMCS.

c. Interval columns. This column determines the time period designated to perform your PMCS.

d. Item to be inspected and procedures column. This column lists functional groups and their respective assemblies and subassemblies as shown in the Maintenance Allocation Chart (Appendix B). The appropriate check or service procedure follows the specific item to be inspected.

Preventive maintenance checks and services for the air conditioners/heaters are contained in TM 5-4120-367-14.

f. List of tools and materials required for PMCS is as follows:

<u>Item</u>	<u>Quantity</u>
Vacuum Cleaner	1 ea
8 in. Adjustable Wrench	1 ea
Cross Tip Screwdriver	1 ea
Flat Tip Screwdriver	1 ea
Spring Scale	1 ea
Padlock	1 ea
Flashlight	1 ea

Table 1-3. ORGANIZATIONAL PREVENTIVE MAINTENANCE CHECKS AND SERVICES

B - Before  
D - During  
A - After

W - Weekly  
M - Monthly  
Q - Quarterly

AN - Annually  
S - Semiannually  
BI - Biennially

(Number) - Hundreds of Hours

ITEM NO.	INTERVAL	ITEM TO BE INSPECTED	PROCEDURE
<b><u>VAN BODY</u></b>			
1	M	<u>Service Air Conditioner/Heater.</u> Refer to TM 5-4120-367-14 for preventive maintenance checks and services.	
2	M	<u>Service Lighting System.</u>	 <p>The diagram illustrates the safety procedure for servicing the lighting system. On the left, a circuit breaker panel is shown with its door open. A hand icon points to a 'VOLTAGE METER' connected to the panel. Below the panel, the text 'CIRCUIT BREAKER OFF' is written. On the right, a 'SAFETY SWITCH OFF' is shown with a padlock attached to its handle, indicating that the main power is locked out.</p>
<b><u>WARNING</u></b>			
<p>Do not open circuit breaker panel or service electrical connections, cables, or switches until main power is off, and voltage meter confirms circuit is not energized. Death may result from failure to observe these safety precautions.</p>			
<ol style="list-style-type: none"> <li>1. Turn off main circuit breaker. Turn off safety switch.</li> <li>2. Padlock safety switch.</li> </ol>			

Table 1-3. ORGANIZATIONAL PREVENTIVE MAINTENANCE CHECKS AND SERVICES - Cont

		B - Before D - During A - After	W - Weekly M - Monthly Q - Quarterly	AN - Annually S - Semiannually BI - Biennially	(Number) - Hundreds of Hours
ITEM NO.	INTERVAL	ITEM TO BE INSPECTED		PROCEDURE	
<b><u>VAN BODY - Cont</u></b>					
2	M	<b><u>Service Lighting System - Cont</u></b>		<ol style="list-style-type: none"> <li>3. Tighten all loose screws, bolts, and clamps.</li> <li>4. Check which switches, switch plate outlets, receptacles, and posts require repair.</li> <li>5. Check for loose screws and nuts on ceiling, console lights, circuit breaker panels, and conduits.</li> <li>6. Remove padlock.</li> <li>7. Turn on main circuit breaker and safety switch.</li> </ol>	
3	M	<b><u>Service Air Vent</u></b>		 <ol style="list-style-type: none"> <li>1. Remove screws from front of grille.</li> <li>2. Remove front grille.</li> <li>3. Using vacuum cleaner, clean screens on side doors. Vacuum inside of air vent.</li> <li>4. Reinstall grille and secure with screws.</li> </ol>	

Table 1-3. ORGANIZATIONAL PREVENTIVE MAINTENANCE CHECKS AND SERVICES - Cont

B - Before  
D - During  
A - After

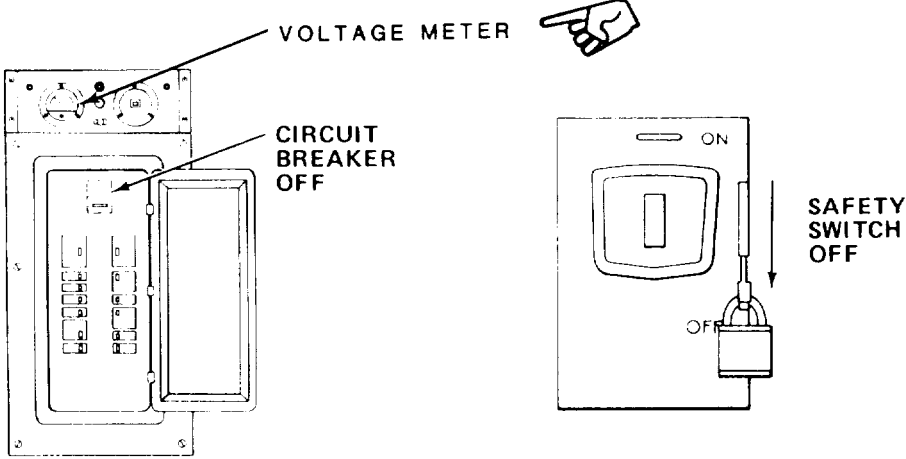
W - Weekly  
M - Monthly  
Q - Quarterly

SN - Annually  
S - Semiannually  
BI - Biennially

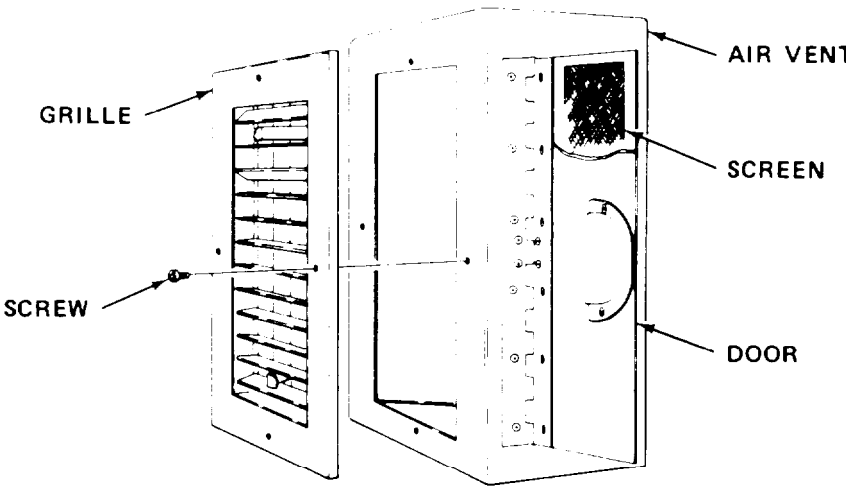
(Number) - Hundreds of Hours

ITEM NO.	INTERVAL	ITEM TO BE INSPECTED PROCEDURE
<b><u>VAN BODY - Cont</u></b>		
4	M	<p data-bbox="371 585 784 617"><u>Inspect Fire Extinguisher.</u></p> <div data-bbox="437 702 1478 1393" style="text-align: center;"> </div> <ol style="list-style-type: none"> <li data-bbox="371 1478 1247 1542">1. Remove from mounting bracket. Check free movement of bracket.</li> <li data-bbox="371 1574 1189 1606">2. Inspect nozzle and adapter assembly for damage.</li> <li data-bbox="371 1638 1082 1670">3. Inspect seal. Be sure it is not broken.</li> </ol> <p data-bbox="289 1702 1214 1766">S 4. Weigh cylinder. Replace if gross weight has decreased by 6 oz (170 g) or more.</p>

## 1-15. ORGANIZATIONAL TROUBLESHOOTING PROCEDURES.

a. Organizational troubleshooting procedures cover the most common malfunctions that may be repaired at the organizational level. Repair or adjustment requiring specialized equipment is not authorized unless such equipment is available. Troubleshooting procedures used by the operator should be conducted in addition to the organizational troubleshooting procedures.

b. This manual cannot list all the possible malfunctions or every possible test inspection and corrective action. If a malfunction is not listed or corrected by a listed corrective action, notify your supervisor.

c. For unidentified malfunctions, use the facing schematic or the foldout located at the end of this manual for further fault analysis.

d. If any component of the Collection Section does not power up when turned on, verify that 120 V ac is present at the receptacle. If voltage is not present, plug equipment into receptacle with power available and proceed with equipment troubleshooting. Perform no-power troubleshooting procedures for dead receptacle (Table 1-4).



Table 1-4. ORGANIZATIONAL TROUBLESHOOTING

MALFUNCTION
TEST OR INSPECTION
CORRECTIVE ACTION

**WARNING**

Electrical shock hazard. Be sure power is off when checking continuity at troubleshooting points. Death or serious injury could result from failure to do so.

## 1. FLUORESCENT CEILING LAMP IS INOPERATIVE.

Step 1. Check for continuity of fluorescent lamp switch.

(a) If continuity exists, proceed to step 2.

(b) If continuity does not exist, replace switch (paragraph 1-16.3).

Step 2. Check for continuity of lamp ballast.

(a) If continuity exists, proceed to step 3.

(b) If continuity does not exist, replace switch (paragraph 1-16.1).

Step 3. Check for shorts in RF Filter.

Replace RF filter (paragraph 1-16.2).

## 2. EXHAUST FAN IS INOPERATIVE.

Check on/off switch for continuity.

(a) If continuity exists, replace fan (paragraph 1-16.9).

(b) If continuity does not exist, replace switch (paragraph 1-16.9).

Table 1-4. ORGANIZATIONAL TROUBLESHOOTING - Cont

MALFUNCTION	TEST OR INSPECTION	CORRECTIVE ACTION
3. EMERGENCY LIGHTS ARE INOPERATIVE.	Press in test indicator.	If lamps do not light, replace emergency light assembly (paragraph 1-16.11).
4. NO POWER TO EQUIPMENT.	Step 1. Check circuit breaker ON/OFF position.	<ul style="list-style-type: none"> <li>(a) If circuit breaker is ON, proceed to step 2.</li> <li>(b) If circuit breaker is OFF, turn ON.</li> <li>(c) If circuit breaker trips repeatedly, notify power supply supervisor.</li> </ul>
	Step 2. Check circuit breaker input for 120 V ac.	<ul style="list-style-type: none"> <li>(a) If input voltage is present, proceed to step 3.</li> <li>(b) If input voltage is not present, refer to direct/general support maintenance for repair or replacement of defective wiring.</li> </ul>
	Step 3. Check circuit breaker output for 120 V ac.	<ul style="list-style-type: none"> <li>(a) If output voltage is present, proceed to step 4.</li> <li>(b) If output voltage is not present, refer to direct/general support maintenance for circuit breaker replacement (paragraph 1-20.5).</li> </ul>
	Step 4. Remove receptacle and check for 120 V ac input.	<ul style="list-style-type: none"> <li>(a) If present, replace receptacle (paragraph 1-16.6).</li> <li>(b) If not present, refer to direct/general support maintenance for repair or replacement of defective wiring.</li> </ul>

**1-16. MAINTENANCE PROCEDURES.**

a. This section contains instructions covering organizational maintenance functions for the Collection Section. Personnel required are listed only if the task requires more than one.

b. After completing each maintenance procedure, perform operational check to be sure that equipment is properly functioning.

**INDEX**

PROCEDURE	PARAGRAPH
Replace Fluorescent Lamp Ballast . . . . .	1-16.1
Replace Radio Frequency (RF) Filter . . . . .	1-16.2
Replace Fluorescent Lamp Switch . . . . .	1-16.3
Replace On/Off Switch. . . . .	1-16.4
Replace Blackout/Dome Light Microswitch . . . . .	1-16.5
Replace Receptacle . . . . .	1-16.6
Replace Wire Molding . . . . .	1-16.7
Repair Telephone Binding Post Assembly . . . . .	1-16.8
Replace Exhaust Fan . . . . .	1-16.9
Replace Exhaust Fan Cover . . . . .	1-16.10
Replace Emergency Light Assembly . . . . .	1-16.11
Repair Blackout Curtain . . . . .	1-16.12
Repair Van Body Skin (Temporary) . . . . .	1-16.13
Replace Tiedown Socket . . . . .	1-16.14
Repair Level Indicator . . . . .	1-16.15
Replace AirVent Screen . . . . .	1-16.16
Replace AirVent Cover . . . . .	1-16.17
Repair Personnel Ladder . . . . .	1-16.18

1-16.1 Replace Fluorescent Lamp Ballast.

MOS: 83FJ6, Reproduction Equipment Repairer

41B, Topographic Instrument Repair Specialist

TOOLS: Flat Tip Screwdriver  
1/4 in. Wrench  
1/4 in. Drive Socket Set  
Scribe

SUPPLIES: Lamp Ballast  
Wire Ties

**WARNING**

Death or serious injury may occur unless overhead light circuit breaker and main circuit breaker are turned off before working on light fixture.

- a. Turn off overhead light, circuit breaker, and main circuit breaker.
- b. Remove diffuser from light fixture.
- c. Remove safety tabs and lamps. Place in diffuser.
- d. Squeeze light wiring guard and remove.
- e. Remove wire ties as required.

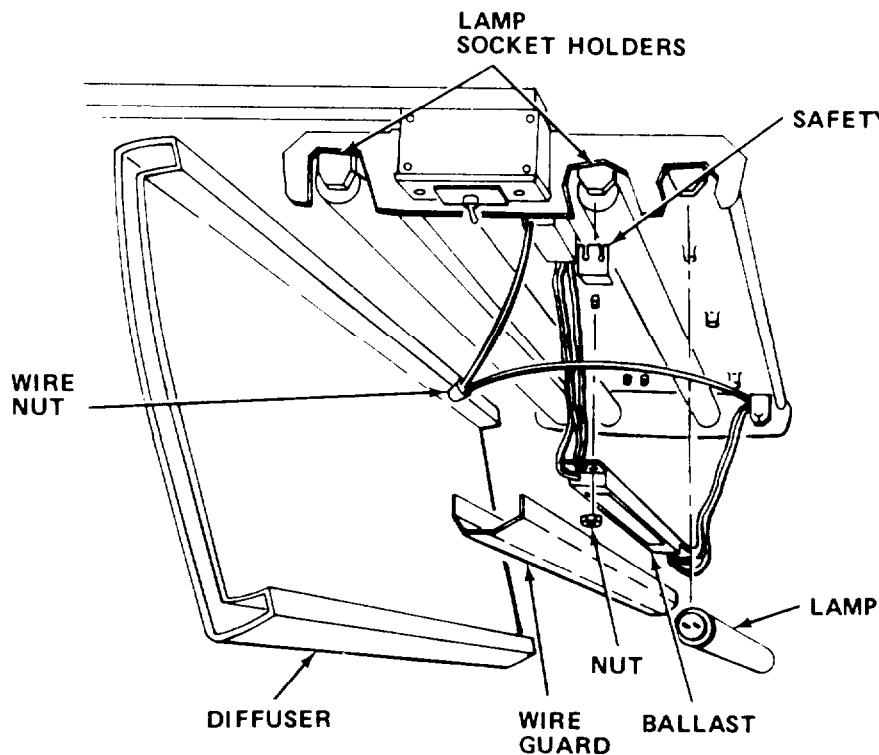

- f. Tag wires from ballast for reference.
- g. Disconnect ballast wire from wire nut connection.
- h. Pry out lamp socket holder with flat tip screwdriver.
- i. Using scribe, depress wire clips and disconnect ballast wiring.
- j. Remove nut and defective ballast.
- k. Install new ballast and connect wires to corresponding lamp socket holders.
- l. Secure with nut.
- m. Reconnect ballast wire to wire nut connection.
- n. Remove tags.
- o. Install new wire ties.

#### **NOTE**

Be sure wires are free of kinks and do not interfere with placement of wire guard.

- p. Reinstall wire guard.
- q. Reinstall lamp and safety tabs.
- r. Reinstall diffuser.
- s. Turn on overhead light circuit breaker and main circuit breaker.

1-16.2 Replace Radio Frequency (RF) Filter.

MOS: 83FJ6, Reproduction Equipment Repairer  
or  
41B, Topographic Instrument Repair Specialist

TOOLS: Flat Tip Screwdriver  
1/4 in. Wrench  
1/4 in. Drive Socket Set

SUPPLIES: RF Filter  
Wire Ties

---

**WARNING**

---

Death or serious injury may occur unless overhead light switch is turned OFF before working on light fixture.

- a. Turn overhead light switch OFF.
- b. Remove diffuser from light fixture.
- c. Remove safety tabs and lamps. Place in diffuser.
- d. Squeeze light wiring guard and remove.
- e. Remove wire ties as required.

- f. Tag wires to filter.
- g. Remove wire nuts and disconnect filter wires.
- h. Remove nuts and defective filter.
- i. Install new filter. Secure with nuts.
- J. Reconnect filter wires and secure with wire nuts.
- k. Remove tags.
- l. Install new wire ties.

**NOTE**

Be sure wires are free of kinks and do not interfere with placement of wire guard.

- m. Reinstall wire guard.
- n. Reinstall lamps and safety tabs.
- o. Reinstall diffuser.
- p. Turn on light switch.

1-16.3 Replace Fluorescent Lamp Switch.

MOS: 83FJ6, Reproduction Equipment Repairer

41B, Topographic Instrument Repair Specialist

TOOLS: Flat Tip Screwdriver  
Needle Nose Pliers  
Flashlight

SUPPLIES: Switch Assembly

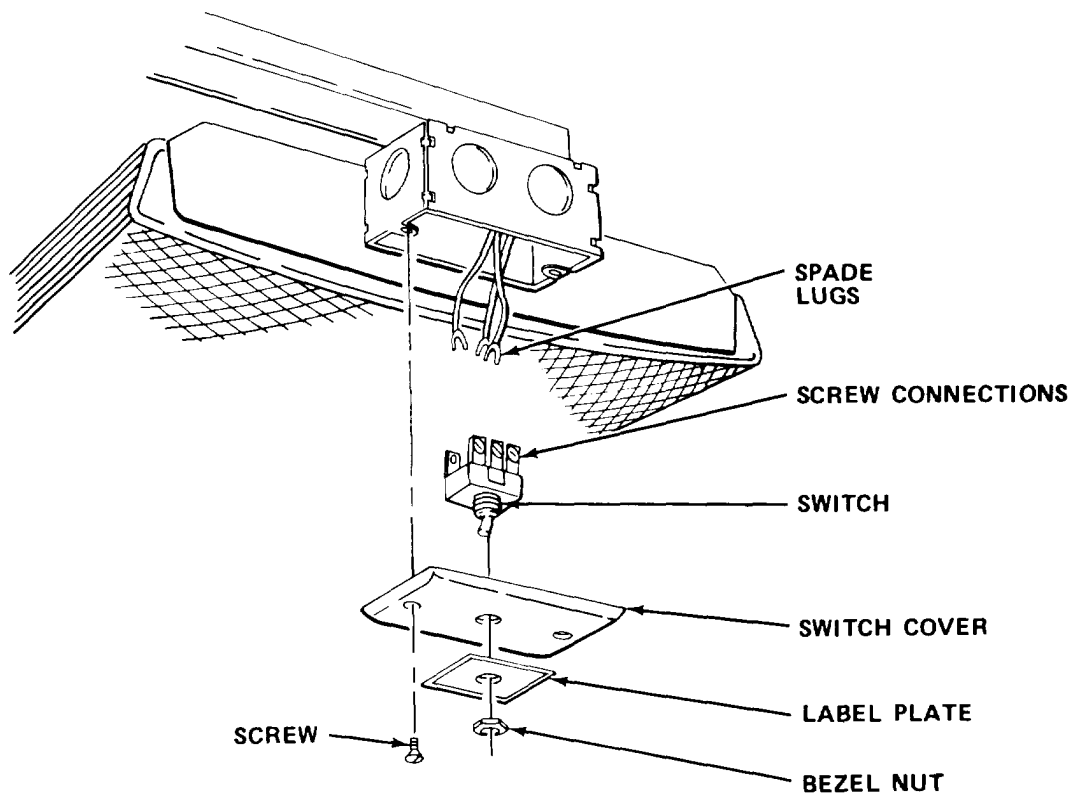



**WARNING**

Death or serious injury may occur if lighting circuit breaker is not turned off before working on lamp assembly.

**NOTE**

Alternate lighting is required to perform this task.

- a. Turn circuit breaker OFF.
- b. Remove bezel nut.
- c. Note notch on label plate and remove label plate.
- d. Loosen screws.

**NOTE**

Note position of cover and reinstall as noted.

- e. Remove cover plate.
- f. Tag and disconnect wires from defective switch.
- g. Install new switch, connect wires, and remove tags.
- h. Insert switch through cover plate and label plate.

**NOTE**

Be sure label plate is in same direction as when removed. Secure with bezel nut.

- i. Aline cover plate with holes and secure with screws.
- j. Turn circuit breaker ON.

1-16.4 Replace On/Off Switch.

MOS: 83FJ6, Reproduction Equipment Repairer  
or  
41B, Topographic Instrument Repair Specialist

TOOLS: Flat Tip Screwdriver

SUPPLIES: Switch

**WARNING**

Death or serious injury may occur if switch circuit breaker is not turned off before working on switch.

- a. Turn off appropriate circuit breaker.

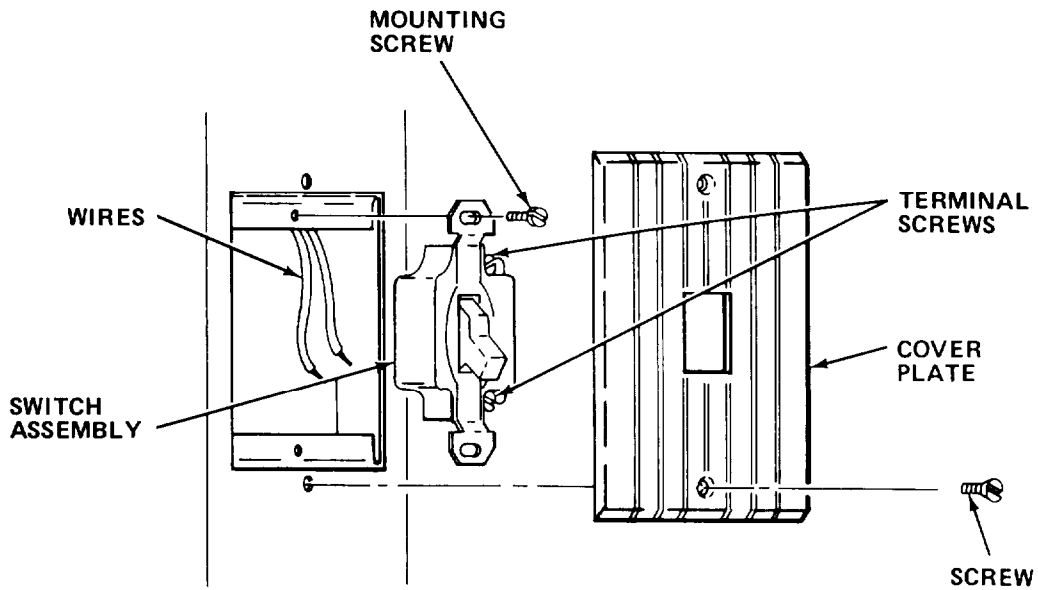

- b. Remove screws.
- c. Remove cover plate.
- d. Remove mounting screws.
- e. Pull switch assembly from wire guide to gain access to wires.
- f. Loosen terminal screws; then disconnect wires.
- g. Install new switch.
- h. Reconnect wires.
- i. Guide switch into wire guide, alining holes.

**NOTE**

Be sure wires are not kinked or strained.

- j. Reinstall mounting screws.
- k. Reinstall cover plate and secure with screws.
- l. Turn on switch circuit breaker.

1-16.5 Replace Blackout/Dome Light Microswitch.

MOS: 83FJ6, Reproduction Equipment Repairer  
or  
41B, Topographic Instrument Repair Specialist

TOOLS: Flat Tip Screwdriver  
6 in. Adjustable Wrench

SUPPLIES: Microswitch

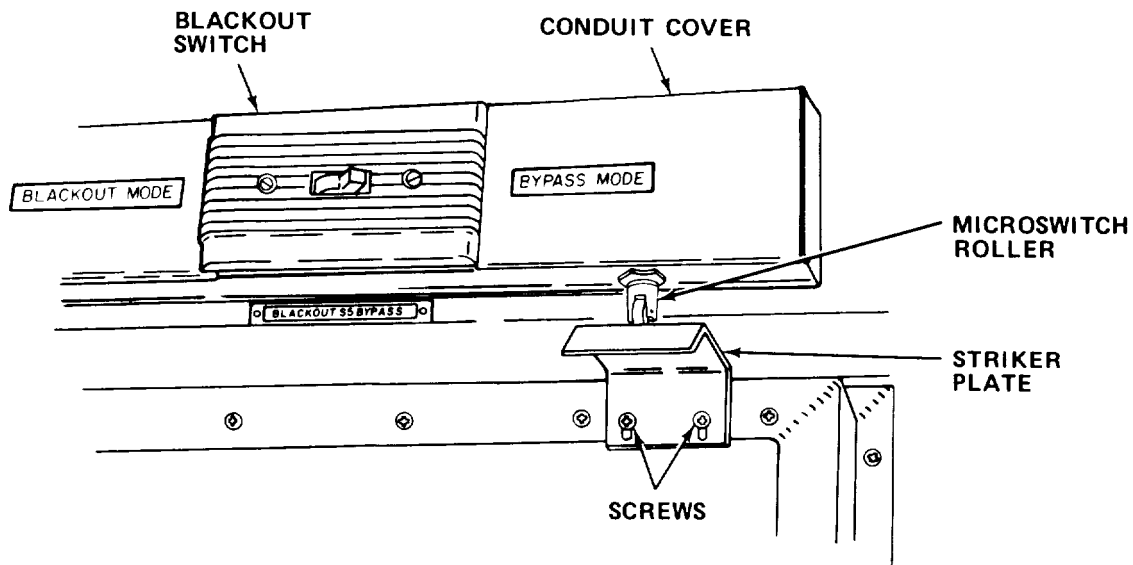

**WARNING**

Death or serious injury may occur from electrical shock unless power is off before servicing.

- a. Turn off blackout/dome light circuit breaker.
- b. Remove conduit cover.
- c. Remove nut and pull out switch to expose wiring.
- d. Disconnect wires from defective switch.
- e. Connect wires to new switch.
- f. Install switch and secure with nut.
- g. Adjust striker plate until plate contacts rollers.
- h. Reinstall conduit cover.
- i. Turn on circuit breaker.

1-16.6 Replace Receptacle.

MOS: 83FJ6, Reproduction Equipment Repairer  
 or  
 41B, Topographic Instrument Repair Specialist

TOOLS: Flat Tip Screwdriver

SUPPLIES: Receptacle

**WARNING**

Death or serious injury may occur if receptacle circuit breaker is not turned off before working on receptacle.

- a. Turn off receptacle circuit breaker.

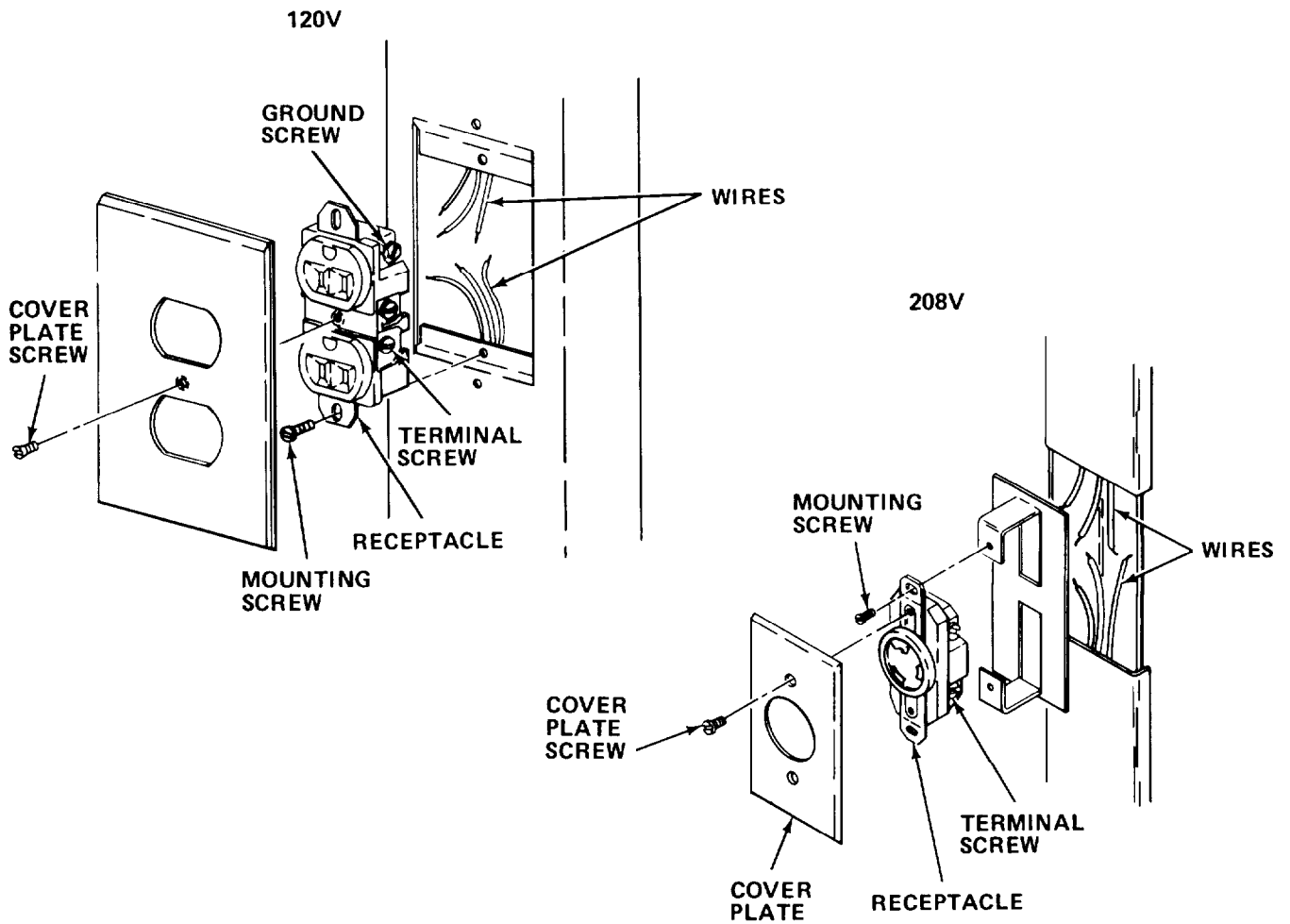

- b. Remove cover plate screws.
- c. Remove cover plate.
- d. Remove mounting screws.
- e. Withdraw receptacle to gain access to wires.
- f. Loosen terminal screws and ground screw. Then disconnect wires.
- g. Reconnect wires. Connect green (ground) wire first.
- h. Install new receptacle.
- i. Guide receptacle into wire guide.

**NOTE**

Be sure wires are not kinked or strained.

- j. Secure receptacle with screws.
- k. Reinstall cover plate. Secure with screws.
- l. Turn on receptacle circuit breaker.

1-16.7 Replace Wire Molding.

MOS: 83FJ6, Reproduction Equipment Repairer  
 or  
 41B, Topographic Instrument Repair Specialist

TOOLS: Flat Tip Screwdriver  
 Hacksaw  
 Flashlight  
 Multimeter  
 Drill and Bits  
 File  
 Machinist Rule

SUPPLIES: Paint (Item 12, Appendix E)  
 Cheesecloth (Item 5, Appendix E)  
 Conduit Base  
 Conduit Cover  
 Padlock  
 Paint Brush

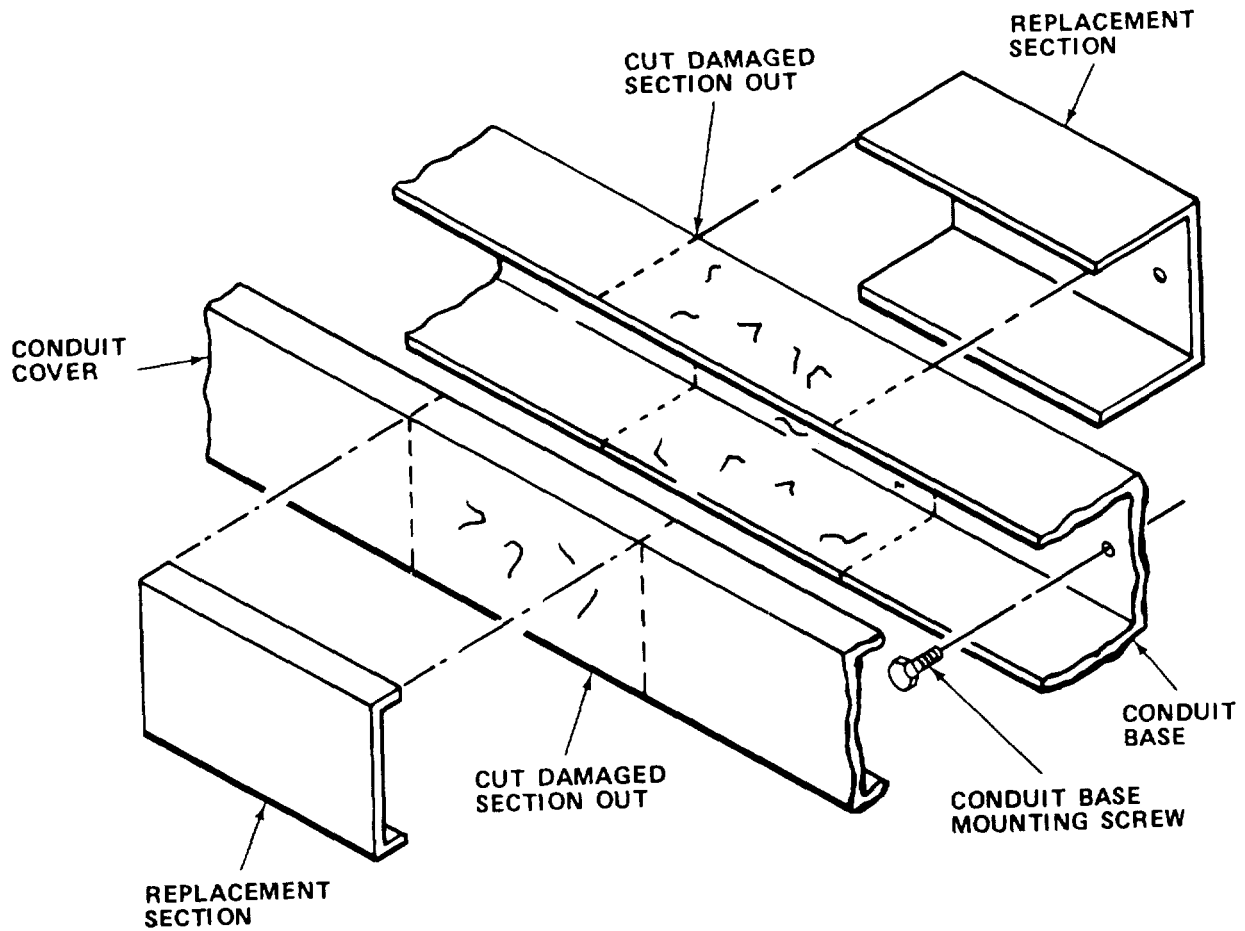

**WARNING**

Death or serious injury may occur from failure to turn off and padlock safety switch before repairing molding.

**NOTE**

Alternate lighting is required to perform this task.

- a. Turn off and padlock safety switch.
- b. Remove conduit cover.
- c. Inspect wires for damage.

**NOTE**

Refer to direct support maintenance for wiring repair if necessary.

- d. Loosen wiring and carefully pull it from the entire base section.
- e. Remove screws and base from wall.
- f. Mark and measure damaged area on molding, Record measurement.
- g. Cut damaged area from molding.
- h. Cut section from new molding to the length recorded in step f.
- i. Using damaged area as a template, mark mounting holes on new piece.
- j. With a number 25 drill bit, drill holes in new molding.
- k. With file, remove all burred edges.
- l. Paint base section as required.
- m. Reinstall conduit base on wall with screws.
- n. Carefully place wiring back in conduit base.
- o. Reinstall cover on base.
- p. Test wiring for continuity between power wires and conduit. If there is continuity, determine and correct grounding fault.
- q. Test wiring with power on.



1-16.8 Repair Telephone Binding Post Assembly.

MOS: 83FJ6, Reproduction Equipment Repairer  
or  
41B, Topographic Instrument Repair Specialist

TOOLS: Cross Tip Screwdriver  
1/2 in. Combination Wrench

SUPPLIES: Binding Post Box  
Binding Posts

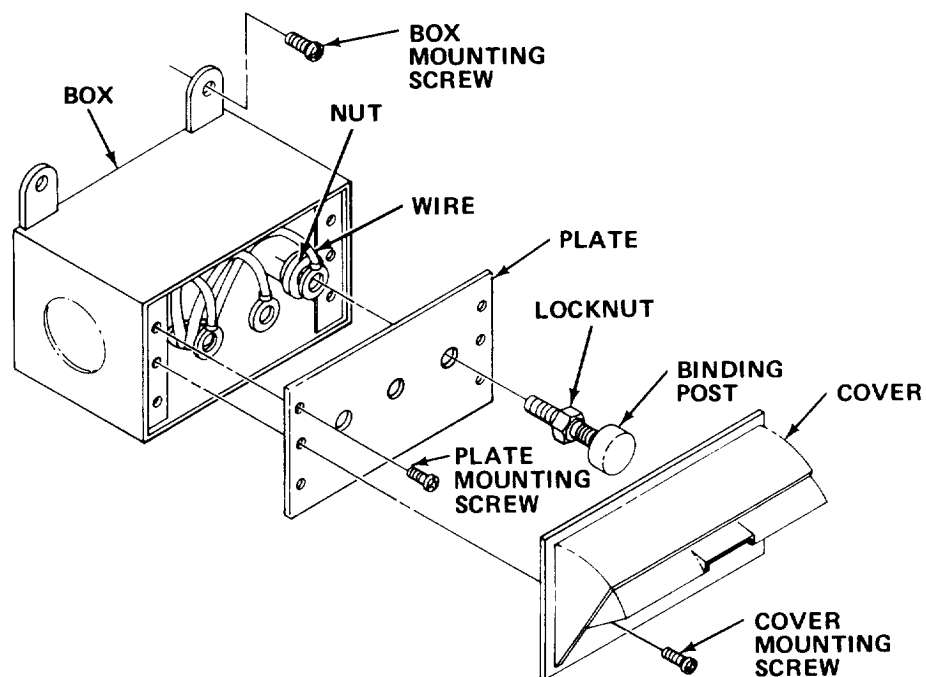

- a. Remove cover mounting screws. Remove cover.
- b. Remove plate mounting screws to gain access to back of plate.
- c. Tag wires for identification.
- d. Remove nuts and wires from binding posts.
- e. If required, remove box mounting screws and replace box.
- f. Replace any defective binding posts. Secure wires new posts and remove tags.
- g. Reinstall box assembly and plate, and secure plate with screws.
- h. Secure cover with screws.

1-16.9 Replace Exhaust Fan.

MOS: 83FJ6, Reproduction Equipment Repairer  
or  
41B, Topographic Instrument Repair Specialist

TOOLS: Flat Tip Screwdriver  
Cross Tip Screwdriver  
Wire Cutters

SUPPLIES: Fan Assembly  
Wire Nuts  
Power Cord

**WARNING**

Death or serious injury may occur if power is left on. Turn fan switch OFF and unplug power cord before working on exhaust fan.

- a. Unplug power cord.

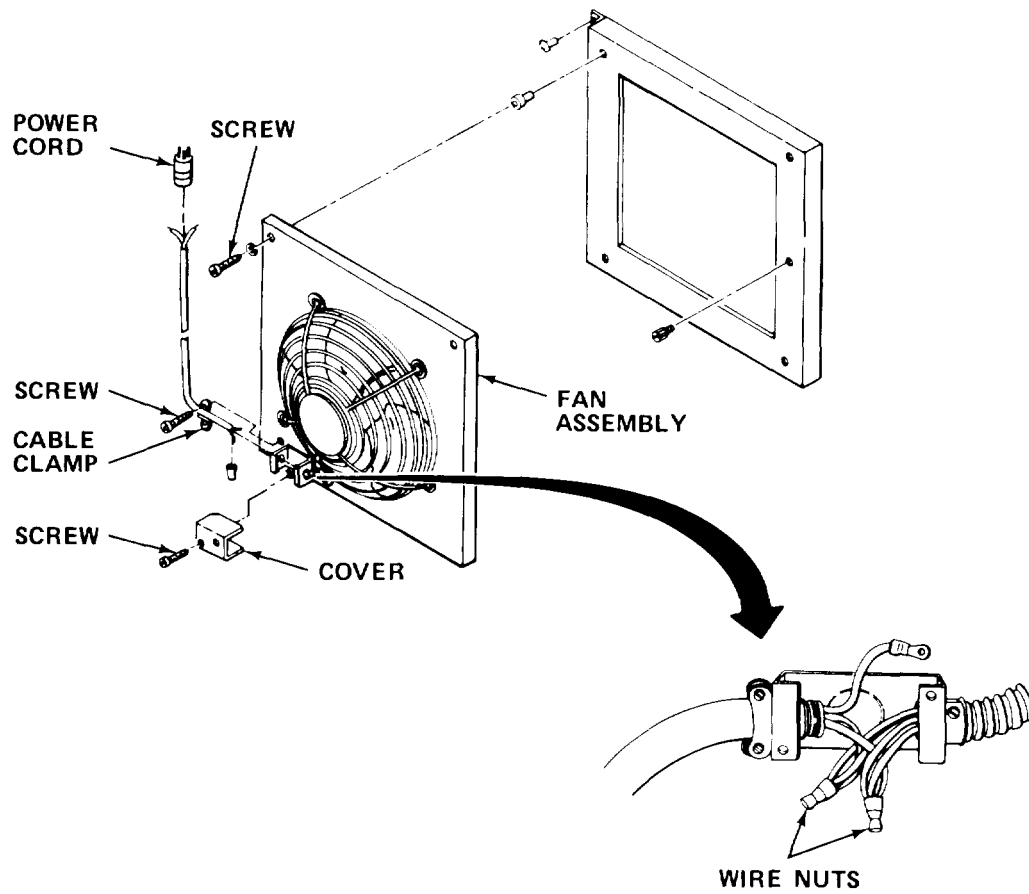

- b. Remove screws and place fan assembly on work surface.
- c. Loosen screws on cable clamp.
- d. Remove screws and cover.
- e. Tag wires and cut wire nuts from wires.
- f. Remove power cord from defective fan assembly.
- g. Install new fan.
- h. Install new power cord.
- i. Connect wires with wire nuts and remove tags.
- j. Tighten cable clamp screws.
- k. Reinstall cover. Secure with screws.
- l. Reinstall fan assembly. Secure with screws.
- m. Plug in power cord.

1-16.10 Replace Exhaust Fan Cover.

MOS: 83FJ6, Reproduction Equipment Repairer  
or  
41B, Topographic Instrument Repair Specialist

TOOLS: Drill and Bits  
Pop Rivet Gun  
Scraper

SUPPLIES: Pop Rivets  
Exhaust Fan Cover  
Gasket  
Solvent P-D-680 (Item 19, Appendix  
Adhesive (Item 2, Appendix E  
Cheesecloth (Item 5, Appendix E)  
Impermeable Gloves  
Goggles

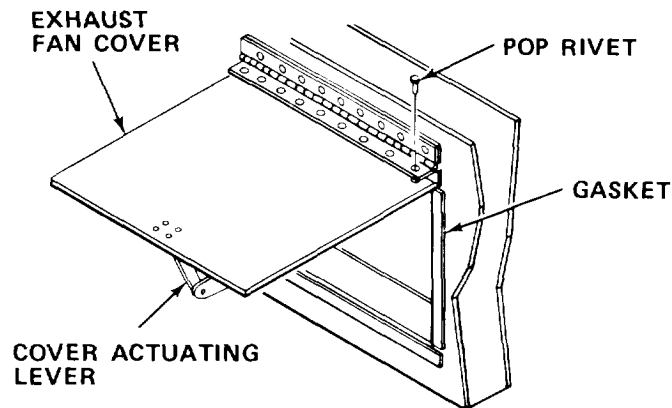

- a. Drill pop rivets from hinged cover to remove vent cover.
- b. Remove defective vent cover and transfer mounting hardware to new cover.

**WARNING**

Dry cleaning solvent, P-D-680, used to clean parts is potentially dangerous to personnel and property. Avoid repeated and prolonged skin contact. Wear solvent-impermeable gloves and eye/face protective equipment when using solvent. Do not use near open flame or excessive heat. Flash point of solvent is 100°F to 138°F (38°C to 59°C).

- c. Scrape gasket off section and clean area with solvent P-D-680.
- d. Secure new gasket to section with adhesive.
- e. Aline exhaust fan vent cover and pop rivet to hinge.
- f. Test cover for tightness of closure.

1-16.11 Replace Emergency Light Assembly.

MOS: 83FJ6, Reproduction Equipment Repairer  
or

41B, Topographic Instrument Repair Specialist

TOOLS: Cross Tip Screwdriver  
Flat Tip Screwdriver

SUPPLIES: Emergency Light Assembly

**WARNING**

Death or serious injury may occur if power cord is not unplugged before servicing light.

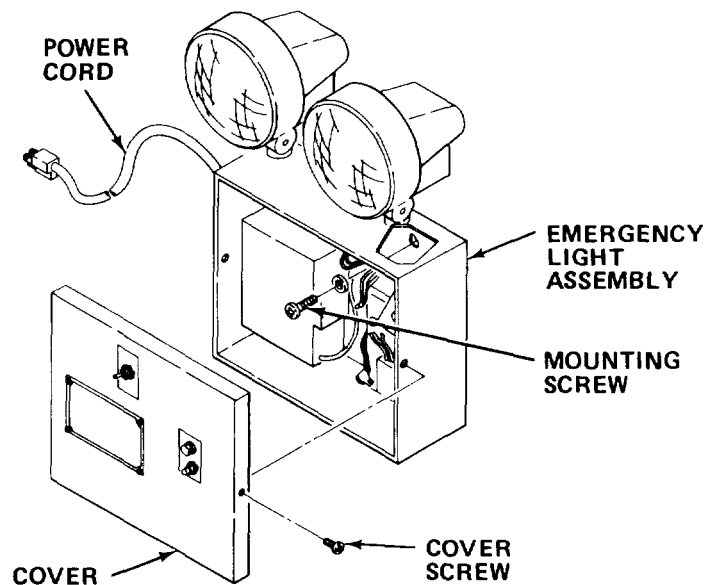

- a. Unplug power cord.
- b. Remove cover screws. Move cover out of way.
- c. Remove mounting screws.
- d. Remove emergency light assembly.
- e. Install new emergency light assembly. Secure with screws.
- f. Secure cover with screws.
- g. Plug in power cord.

1-16.12 Repair Blackout Curtain.

MOS: 83FJ6, Reproduction Equipment Repairer  
or  
41B, Topographic Equipment Reps Specialist

TOOLS: Cross Tip Screwdriver

SUPPLIES: Hooks  
Valance  
Curtain  
Nylon Hook and Pile Tape  
Adhesive (Item 1, Appendix E)

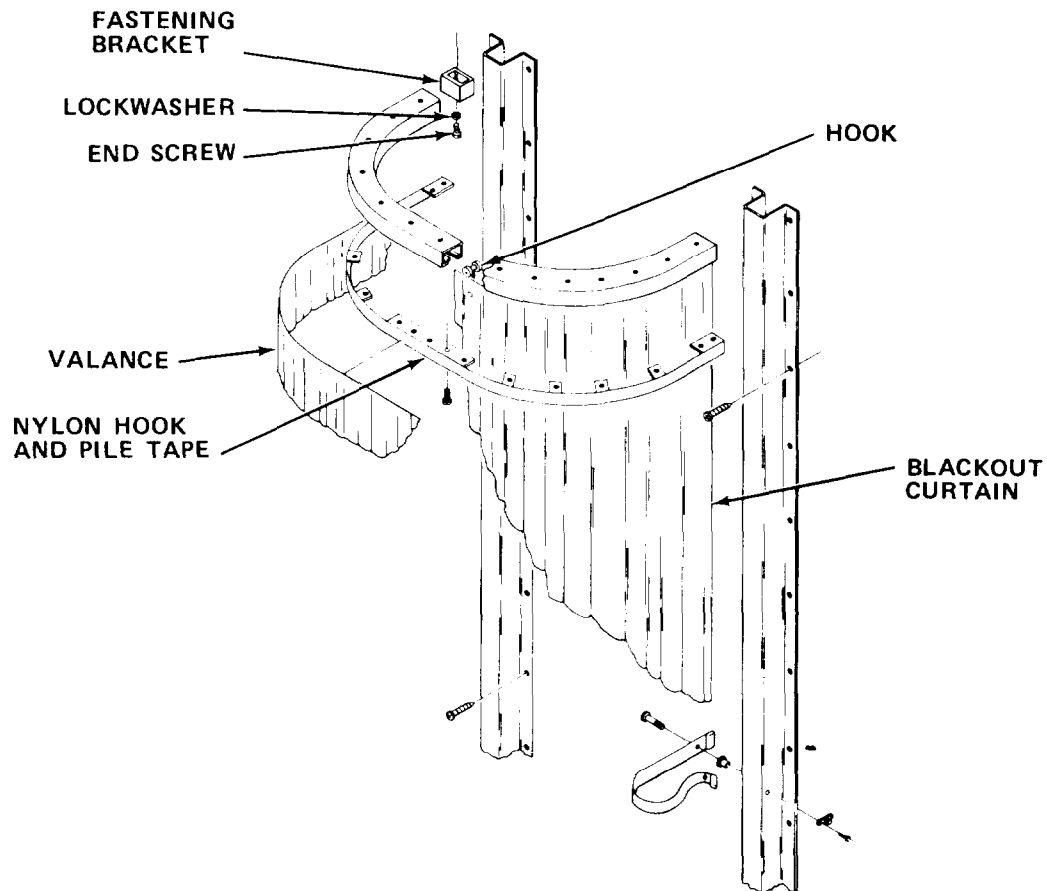

- a. Remove curtain from hooks.
- b. Pull curtain and valance from nylon hook and pile tape.
- c. Remove end screw, lockwasher, and fastening bracket from ceiling.
- d. Replace damaged hooks.

- e. Reinstall fastening bracket with hooks. Fasten with end screw and lockwasher.
- f. Glue loose nylon hook and pile tape to wall or bracket. Replace tape if worn out.
- g. Hook curtain to bracket.
- h. Attach valance.
- i. Check curtain for free movement.

1-16.13 Repair Van Body Skin (Temporary).

MOS: 52C, Utilities Equipment Repairer

TOOLS: Pliers  
 Ball Peen Hammer  
 Scissors or Utility Knife

SUPPLIES: Cloth Duct Sealing Tape (Item 22, Appendix E)  
 Silicone Sealant (Item 17, Appendix E)  
 Sprayfoam (Item 21, Appendix E)  
 Cheesecloth, (Item 5, Appendix E)

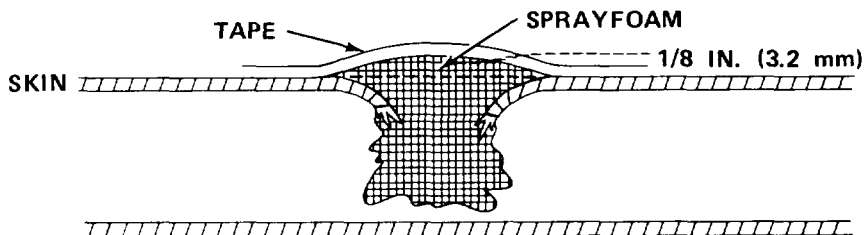

- a. Bend broken edges of punctured skin inward into puncture hole. Do not attempt to remove fragments of skin by bending or pulling outward. Bend skin inward only enough to put broken edges below surface of unbroken skin.
- b. Remove any loose fragments of foam which are not now held in place by bent broken skin. Removing small pieces of foam or dust is more important than removing chunks.

- c. Using cloth slightly dampened with water, wipe area around puncture to remove any dirt or mud and wipe dry.
- d. Inject sprayfoam into puncture. Mound sprayfoam to about 1/8 in. (3.2 mm) above surface of unbroken skin. Apply bead of sealant about 1/4 in. (6.4 mm) wide over all cuts in skin leading out from puncture. Do not smooth out sealant.
- e. Plan how puncture is to be covered with tape before applying any tape. Length and width of tape, number of tape strips, overlapping, and how tape is applied will affect sealing capability of repair. Each piece of tape should extend about 1-1/2 in. (3.81 cm) beyond sealant it will cover. If this will require more than one strip of tape, tape should overlap about 1/2 in. (12.7 mm). If three or more strips of tape are required, center strip should be applied first.
- f. Holding tape taut, apply it perpendicular to panel skin. Do not apply with rolling motion either end-to-end or center-to-ends. Do not rub each strip in place individually. Apply all strips lightly with proper overlap and rub into place.
- g. If necessary damaged tape can be replaced; however, it should be removed with careful peeling motion to avoid damage to sealant. If sealant also peels back, new sealant should be applied. Complete removal of old sealant is not necessary. Permanent repair by direct support or higher category of maintenance, should be made as soon as possible.



**1-16.14 Replace Tiedown Socket.**

MOS: 83FJ6, Reproduction Equipment Repairer

41B, Topographic Instrument Repair Specialist

TOOLS: Cross Tip Screwdriver  
Flat Tip Screwdriver

SUPPLIES: Tiedown Socket

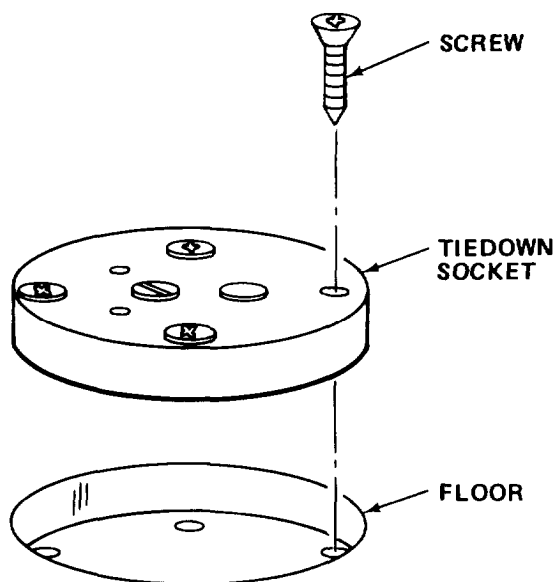

- a. Remove screws from tiedown socket.
- b. Pry defective socket from floor.
- c. Install new tiedown socket. Rotate new tiedown socket enough to avoid installing screws in old screw holes.
- d. Reinstall screws.

1-16.15 Repair Level Indicator.

MOS: 83FJ6, Reproduction Equipment Repairer  
or  
41B, Topographic Instrument Repair Specialist

TOOLS: Carpenter's Level  
Cross Tip Screwdriver  
Knife, TL-29

SUPPLIES: Level Indicator  
Gasket

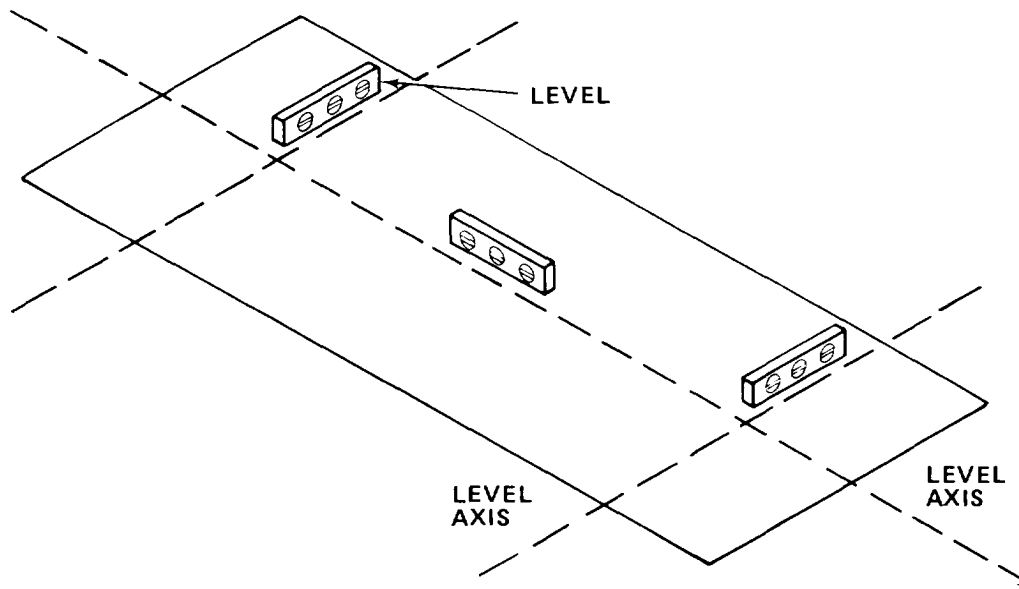

- a. Level section using level indicators. Then confirm section is level by using carpenter's level on floor inside section.

- b. Adjust section leveling jacks until section is level as indicated by carpenter's level at front-rear and left-right at each end as shown in illustration.

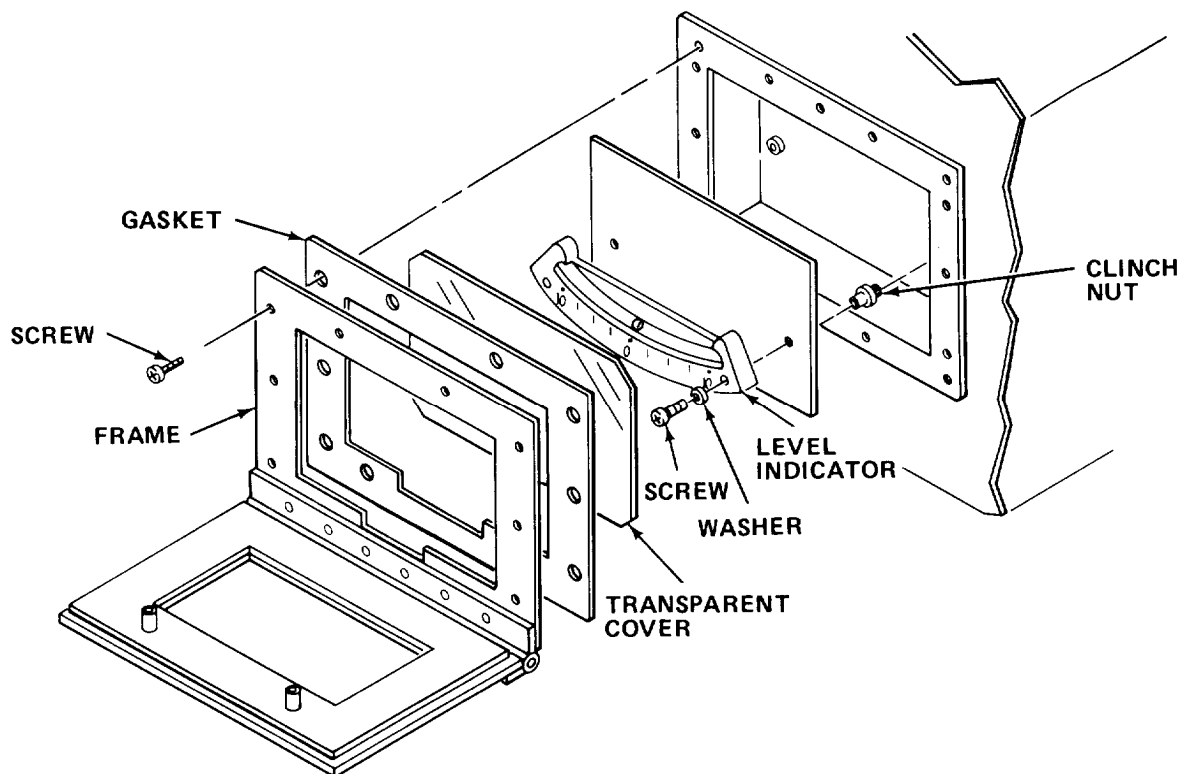

- c. Loosen knurled screws and move cover away from level assembly.  
 d. Remove screws and washers to release frame and gasket.  
 e. Remove transparent cover.  
 f. Remove screws and washers to remove level indicator.  
 g. Replace level indicator and secure with screws and washers.  
 h. Reinstall transparent cover.  
 i. Install new gasket.  
 j. Reinstall frame and secure with screws and washers.

1-16.16 Replace Air Vent Screen.

MOS: 83FJ6, Reproduction Equipment Repairer  
or  
41B, Topographic Instrument Repair Specialist

TOOLS: Cross Tip Screwdriver  
Scissors

SUPPLIES: Rubber Adhesive (Item 1, Appendix E)  
Nylon Screen (Item 16, Appendix E )

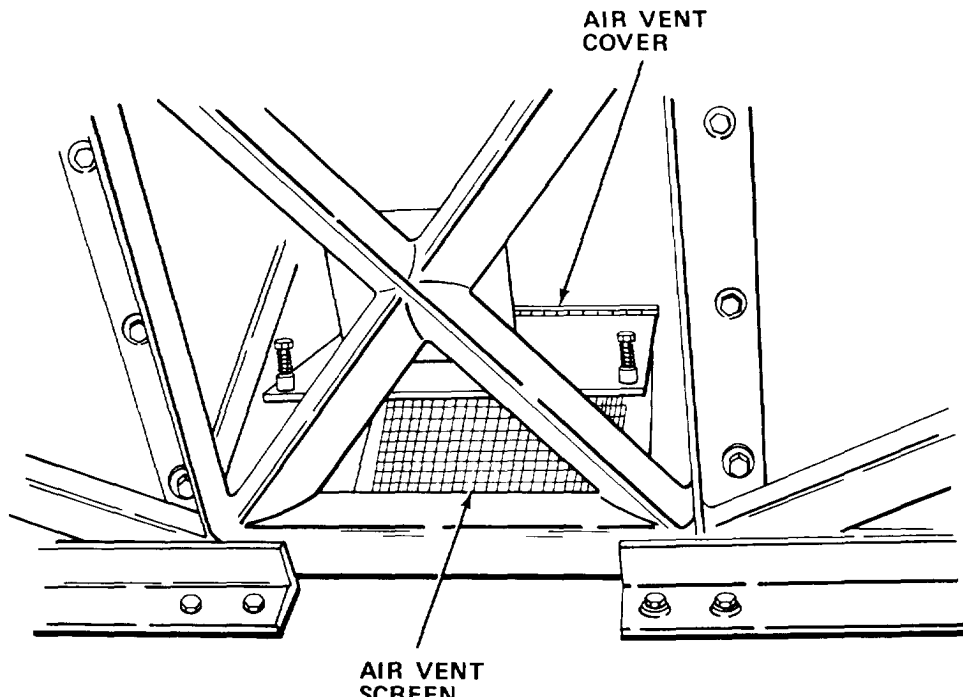

- a. Raise access cover and remove screws holding screen frame to section.
- b. Remove screen and frame.
- c. Clean all old screen material and adhesive from frame.
- d. Cut new screen material to size and attach to frame with adhesive.
- e. Reinstall frame to section and secure with screws. Lower cover.

1-16.17 Replace Air Vent Cover.

MOS: 83FJ6, Reproduction Equipment Repairer

41B, Topographic Instrument Repair Specialist

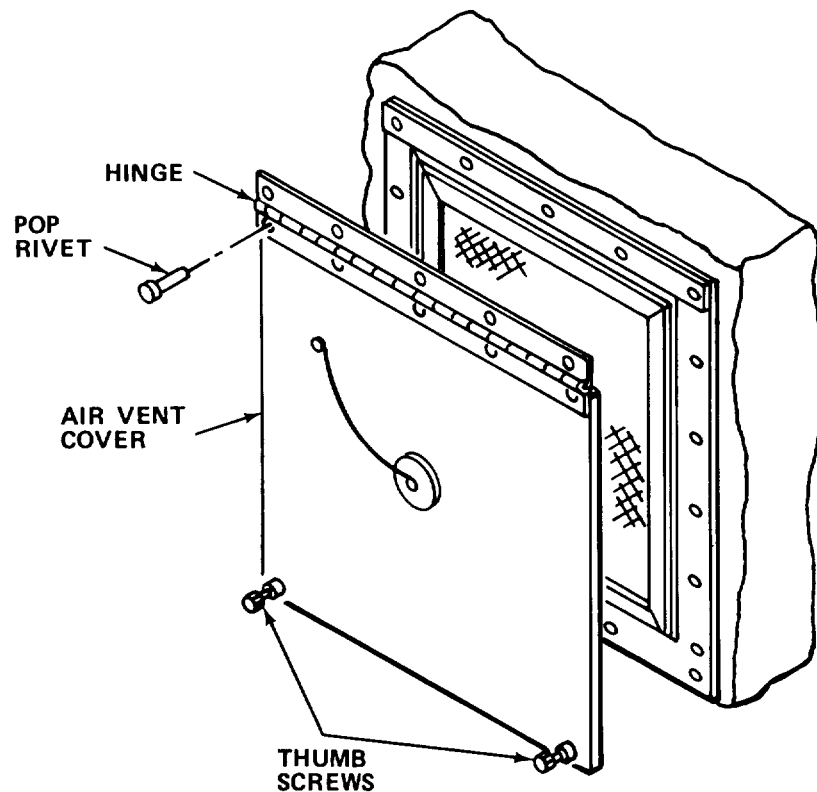
TOOLS: Drill and Bits  
Pop Rivet GunSUPPLIES: Vent Cover  
Pop Rivets

- a. Loosen thumbscrews.
- b. Drill pop rivets from hinge. Remove air vent cover.
- c. Aline holes and pop rivet new air vent cover to section.
- d. Tighten thumbscrews.

1-16.18 Repair Personnel Ladder.

MOS: 63W, Wheel Vehicle Repairer

TOOLS: Drill and Bits  
Pop Rivet Gun  
9/16 in. Combination Wrench  
8 in. Adjustable Wrench

SUPPLIES: Cable Assembly  
Locking Pins  
Pop Rivets  
Mounting Brackets

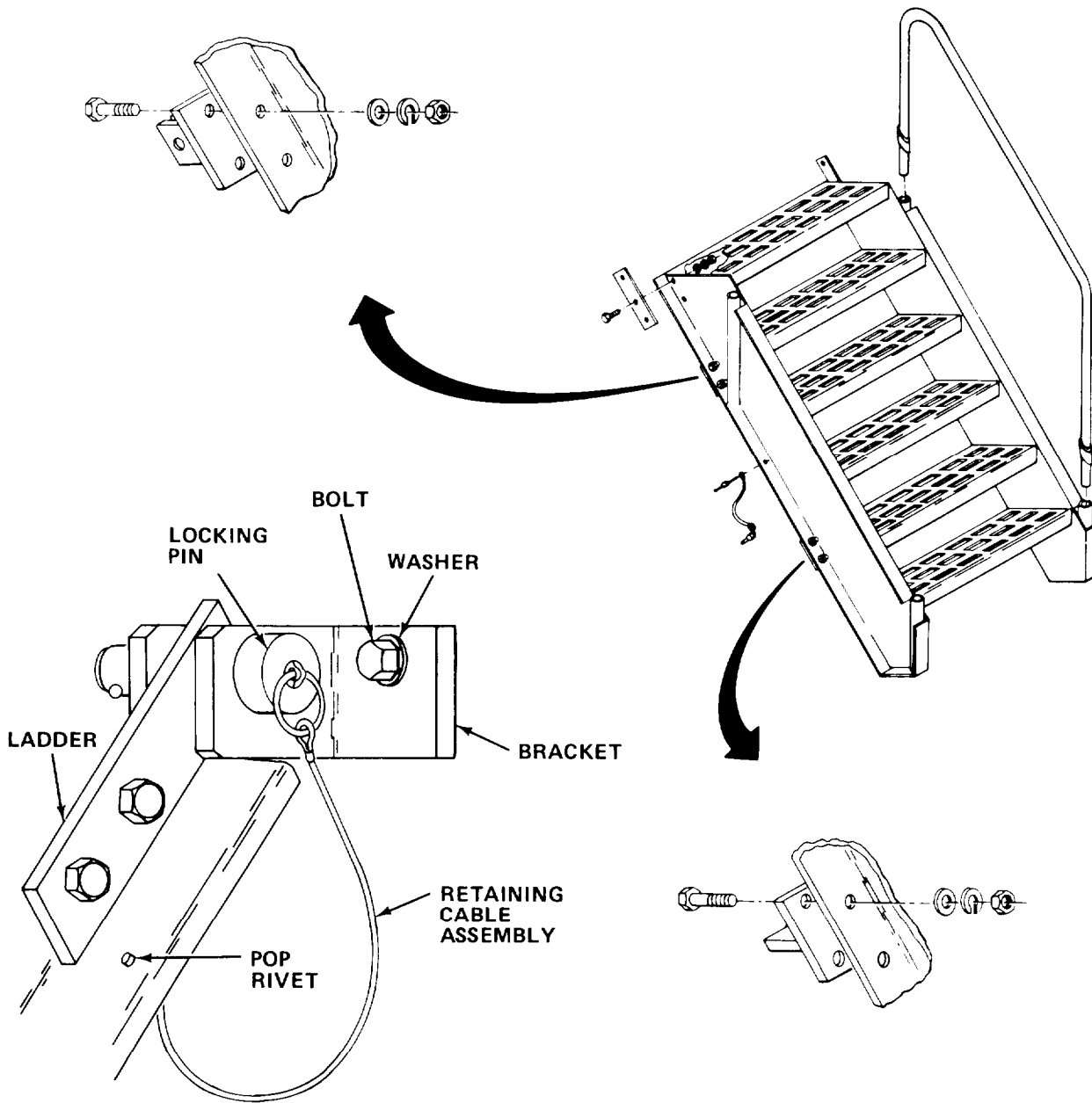

- a. Remove ladder from mounting bracket.
- b. Remove bolts, washers, and nuts securing damaged mounting brackets to ladder.
- c. Remove damaged cable assembly from ladder by drilling out rivet.
- d. Reinstall or install new mounting brackets. Secure with bolts, washers, and nuts.
- e. Rivet new cable assembly to ladder.

#### NOTE

Be sure ladder mounting brackets fit section on rear door and under personnel doors.

- f. Reinstall ladder on mounting bracket.

#### 1-17. PREPARATION FOR STORAGE OR SHIPMENT.

a. Section may be stored or shipped either mounted on trailer chassis or unmounted. Preparation of trailer chassis is covered in TM 5-2330-305-14 and should be referred to when trailer-mounted section is prepared for storage and shipment. TM 5-4120-367-14 must be reviewed for instructions covering air conditioner/heater

b. Remove consumable supplies that have limited shelf life or broken seals. Replace missing items and be sure that all remaining consumable supplies are at authorized levels. Be sure all major components are operational.

c. Remove all unauthorized or personal equipment from section.

d. Move all classified material or sensitive data to proper storage. Complete all accountability and/or transfer of documents.

e. Refer to Preparation for Movement (paragraph 1-6.2) and follow applicable steps and any additional steps directed by proper authority.

## Section V DIRECT/GENERAL SUPPORT MAINTENANCE

### 1-18. REPAIR PARTS, SPECIAL TOOLS; TEST, MEASUREMENT, AND DIAGNOSTIC EQUIPMENT (TMDE); AND SUPPORT EQUIPMENT.

1-18.1 Common Tools and Equipment. For authorized common tools and equipment, refer to the Modified Table of Organization and Equipment (MTOE) applicable to your unit.

1-18.2 Special Tools: Test, Measurement, and Diagnostic Equipment; and Support Equipment. Special Tools, TMDE, and Support Equipment is listed in the applicable repair parts and special tools list and in Appendix B of this manual.

1-18.3 Repair Parts. Repair parts are listed and illustrated in the Repair Parts and Special Tools List, TM 5-6675-322-24P covering direct/general support maintenance for this equipment.

1-18.4 Electrical System. Direct/general support level of maintenance for the repair of the section's electrical system will consist of electrical wiring repair using standard electrical wiring repair procedures.

### 1-19. DIRECT/GENERAL SUPPORT TROUBLESHOOTING PROCEDURES.

a. Direct/general support troubleshooting procedures cover the most common malfunctions that may be repaired at the direct/general support level. Repair or adjustment requiring specialized equipment is not authorized unless such equipment is available. Troubleshooting procedures used by lower level maintenance should be conducted in addition to the direct/general support troubleshooting procedures.

b. This manual cannot list all the possible malfunctions or every possible test/inspection and corrective action. If a malfunction is not listed or corrected by a listed corrective action, notify your supervisor.

For unidentified malfunctions, use the facing schematic or the foldout located at the end of this manual for further fault analysis.



**Table 1-5. DIRECT/GENERAL SUPPORT TROUBLESHOOTING**

---

MALFUNCTION
TEST OR INSPECTION
CORRECTIVE ACTION

---

1. PERSONNEL/CARGO DOORS DO NOT CLOSE COMPLETELY.
  - Step 1. Check that latch rollers rotate freely.
    - Replace latches (paragraph 1-20.2).
  - Step 2. Check to see if latch rods are bent.
    - Replace latch rods (paragraph 1-20.2).
  - Step 3. Check to see if door gasket is torn or broken.
    - Replace door gasket (paragraph 1-20.3).
  
2. PERSONNEL/CARGO DOORS DO NOT LATCH PROPERLY.
  - Check door latch for missing or damaged components.
    - Replace door latch (paragraph 1-20.2).
  
3. AIR OR WATER ENTERS SECTION AROUND DOOR.
  - Check to see if door gasket is worn or broken.
    - Replace door gasket (paragraph 1-20.3).

Table 1-5. DIRECT/GENERAL SUPPORT TROUBLESHOOTING - Cont

---

MALFUNCTION

TEST OR INSPECTION

CORRECTIVE ACTION

---

4. RECEPTACLES DO NOT OPERATE BUT CIRCUIT BREAKERS ARE ON.

**WARNING**

Turn off main circuit breaker before inspecting or servicing circuit breakers or receptacles. Failure to do so may result in death or serious injury.

Step 1. Check to see if power cable is firmly connected to power entry panel .

Connect power cable.

Step 2. Check to see if voltage meter and frequency scale and INCORRECT PHASE or CORRECT PHASE lamp indicate necessary power.

Notify your supervisor for service of power supply at source.

5. CIRCUIT BREAKERS TRIP CONTINUALLY.

**WARNING**

Turn off and padlock safety switch before inspecting or servicing circuit breakers or receptacles. Failure to do so may result in death or serious injury.

Step 1. Check to see if receptacles are overloaded.

Reconnect equipment to different receptacles.

Step 2. Check to see if receptacles are damaged.

Replace receptacles (paragraph 1-16.6)

---

**1-20. MAINTENANCE PROCEDURES.**

a. This section contains instructions covering direct/general support maintenance functions for the Collection Section. Personnel required are listed only if the task requires more than one.

b. After completing each maintenance procedure, perform operational check to be sure that equipment is properly functioning.

**INDEX**

PROCEDURE	PARAGRAPH
Repair Personnel Door Handle . . . . .	1-20.1
Replace Cargo Door Latch Assembly . . . . .	1-20.2
Replace Personnel/Cargo Door Gasket . . . . .	1-20.3
Replace Personnel/Cargo Door . . . . .	1-20.4
Replace Circuit Breaker . . . . .	1-20.5
Repair Floor Covering . . . . .	1-20.6
Repair Van Body Skin (Permanent) . . . . .	1-20.7
Replace Air Conditioner/Heater . . . . .	1-20.8
Replace Air Conditioner Support Bracket . . . . .	1-20.9
Replace Ventilation Duct . . . . .	1-20.10

1-20.1 Repair Personnel Door Handle.

MOS: 63W, Wheel Vehicle Repairer

TOOLS: Cross Tip Screwdriver  
Needle Nose Pliers  
15/16 in. Combination Wrench  
Hammer  
Center Punch  
1/8 in. Hex Head Key Wrench

SUPPLIES: O-Ring Washer  
Sleeve  
Roll Pin  
Personnel Door Handle  
Cheesecloth (Item 5, Appendix E)  
Oil, Lubricating, General Purpose (Item 10, Appendix E)  
Hand Oiler  
Cotter Pin  
Washer

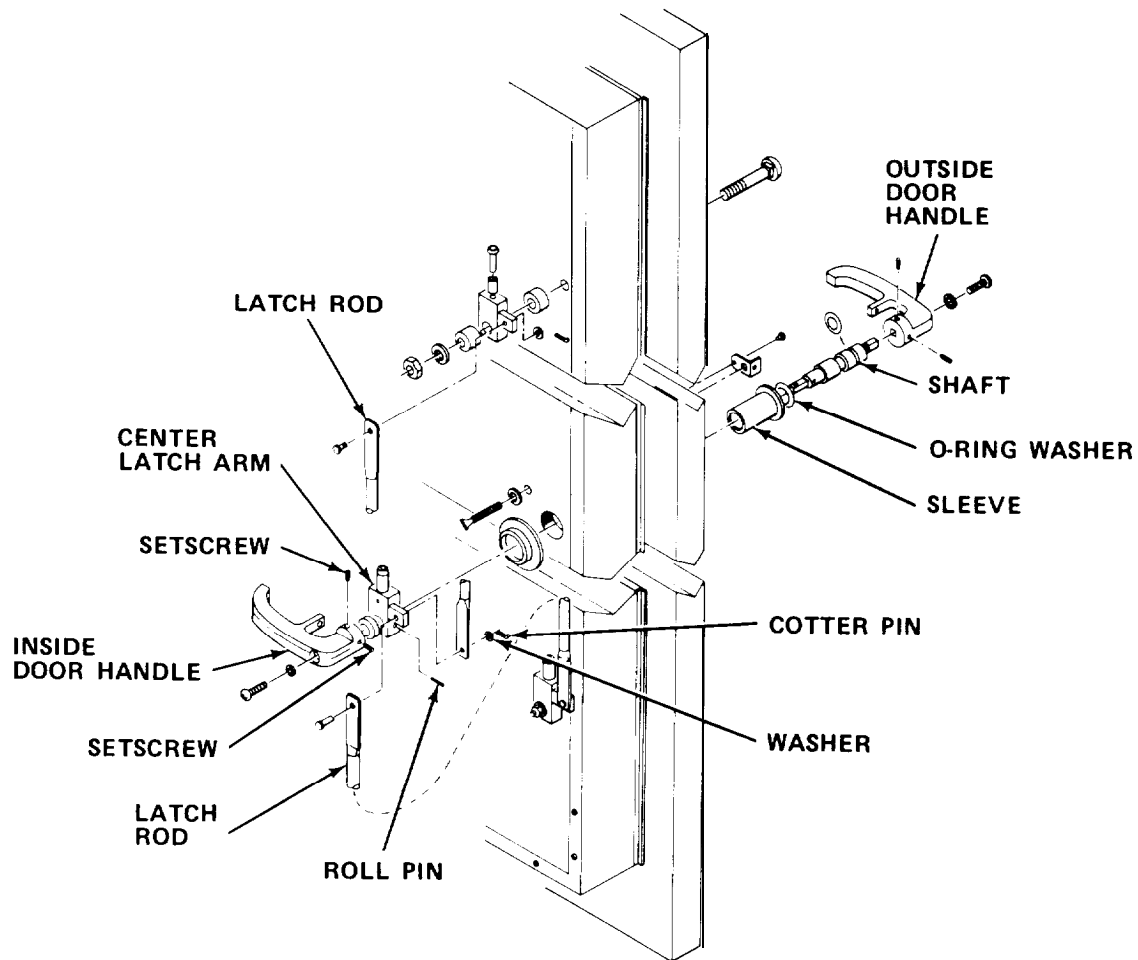

- a. Loosen screw and socket head setscrews. Remove defective inside door handle.
- b. Remove cotter pin and pins from center latch arm assembly.
- c. Move latch rods out of way.
- d. Punch roll pin from center latch arm assembly and pull latch arm assembly from shaft.
- e. Withdraw latch and defective outside door handle.
- f. Inspect all components for wear.
- g. Replace worn O-ring washer and sleeve.
- h. Replace other worn components as needed.
- i. Reinstall latch and new outside door handle.
- j. Aline center latch arm assembly on shaft. Secure with new roll pin.
- k. Aline latch rods. Attach to latch arms with pins, washers, and new cotter pin.
- l. Reinstall new inside door handle.
- m. Lightly oil all moving parts. Wipe up surplus oil.

1-20.2 Replace Cargo Door Latch Assembly.

MOS: 63W, Wheel Vehicle Repairer

TOOLS: 9/16 in. Combination Wrench

SUPPLIES: Cargo Door Latch Assembly

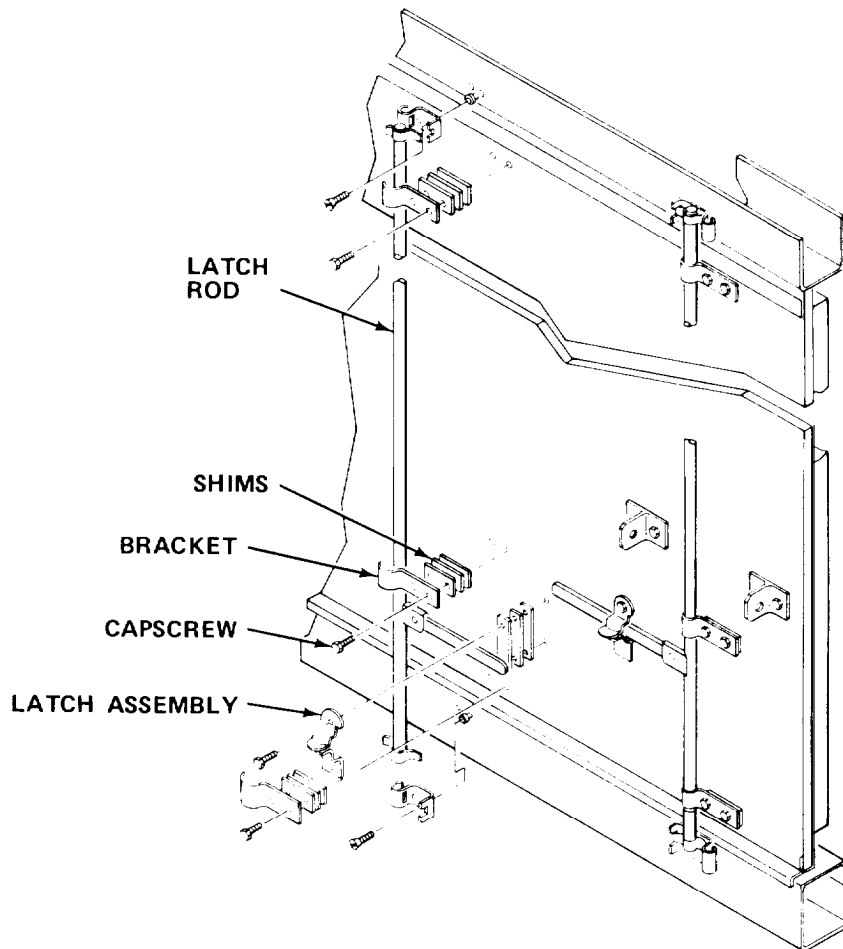

- a. Unlock latch.
- b. Remove capscrows and washers from brackets. Remove brackets and shims.
- c. Remove defective latch assembly and latch rod.
- d. Install new latch assembly and latch rod.
- e. Reinstall shims, brackets, washers, and capscrows.
- f. Check movement of latch rod and latch assembly. Lock latch.

1-20.3 Replace Personnel/Cargo Door Gasket.

MOS: 63W, Wheel Vehicle Repairer

TOOLS: Knife

SUPPLIES: Vinyl Gasket  
Adhesive (Item 2, Appendix E)  
Solvent P-D-680 (Item 19, Appendix E)  
Impermeable Gloves  
Goggles

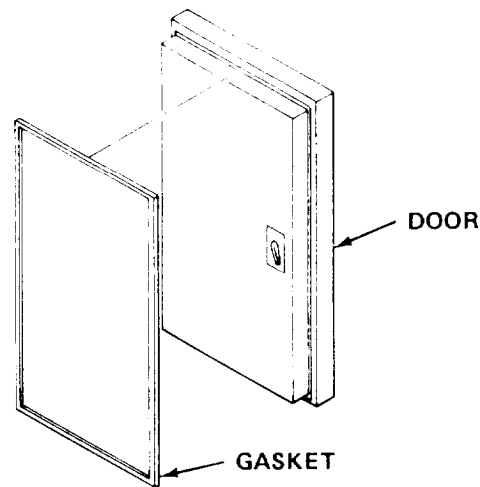

- a. Open door completely and secure in open position.

---

**WARNING**

---

Dry cleaning solvent, P-D-680, used to clean parts is potentially dangerous to personnel and property. Avoid repeated and prolonged skin contact. Wear solvent-impermeable gloves and eye/face protective equipment when using solvent. Do not use near open flame or excessive heat. Flash point of solvent is 100°F to 138°F (38°C to 59°C).

- b. Remove defective gasket by prying gasket from door. Scrape traces of gasket and adhesive from door. Wash with solvent P-D-680.
- c. Coat gasket area on door with adhesive.
- d. Firmly press new gasket onto door.
- e. Wipe excess adhesive from gasket.
- f. Close door and wipe excess adhesive from door and frame.
- g. Allow adhesive to dry before using door.

1-20.4 Replace Personnel/Cargo Doors.

MOS: 63W, Wheel Vehicle Repairer

PERSONNEL: Two persons are required to perform this procedure.

TOOLS: Pop Rivet Gun  
Electric Drill and Bits  
Hoist  
3/4 in. Combination Wrench  
Paint Brush

SUPPLIES: Personnel/Cargo Door  
Pop Rivets  
Vinyl Gasket  
Paint (Items 11, 11A and 11B, Appendix E)  
Paint (Item 12, Appendix E)  
Adhesive (Item 2, Appendix E)  
Cheesecloth (Item 5, Appendix E)

**WARNING**

To prevent personal injury or equipment damage, do not attempt to remove doors unless suitable lifting equipment and hoist are available.

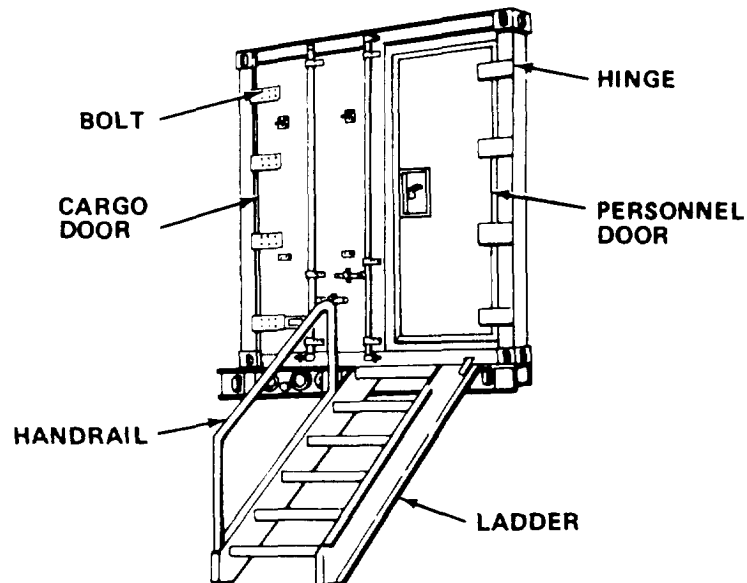

- a. Remove handrails and ladders if rear cargo door is to be replaced.
- b. Unlock and open door to be replaced.



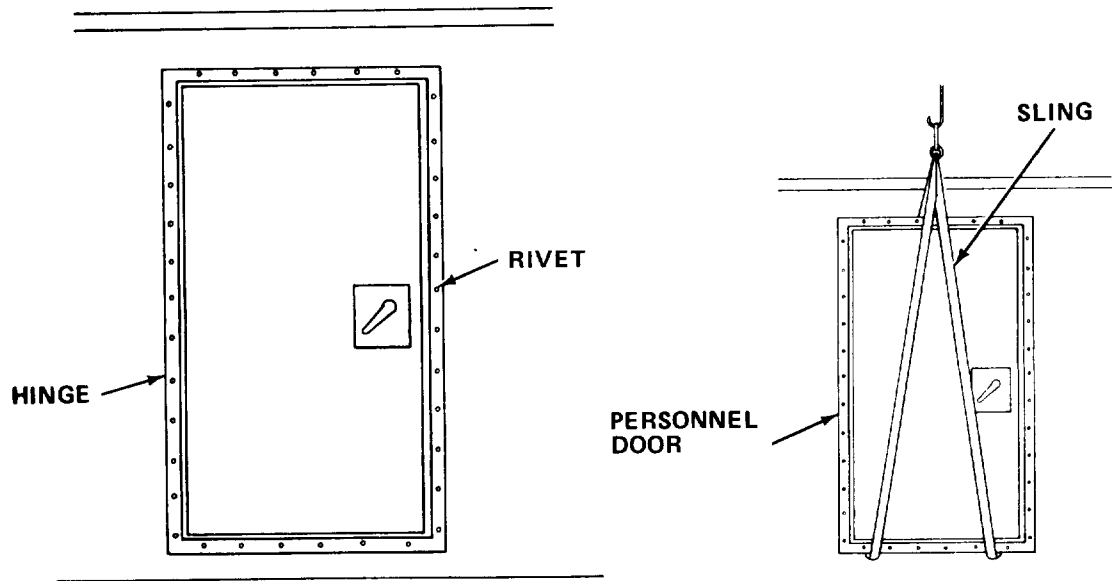

- c. Place sling around door and put a slight strain on hoist to remove weight from hinges.
- d. Remove bolts from hinges on rear personnel door. On side personnel door, drill out pop rivets from hinge. Remove hinges from door.
- e. Remove damaged door using hoist.
- f. Install new door using hoist.
- g. Reinstall hinges on rear personnel door. Secure with bolts. Reinstall hinges on side personnel door. Secure with pop rivets.
- h. Remove sling from door.
- i. Install new gaskets on door after it is mounted (paragraph 1-20.3).
- j. Repaint as needed.
- k. Close and lock door.

1-20.5 Replace Circuit Breaker.

MOS: 35E, Special Electronic Devices Repairer

TOOLS: Flat Tip Screwdriver  
Multi meter

SUPPLIES: Circuit Breaker

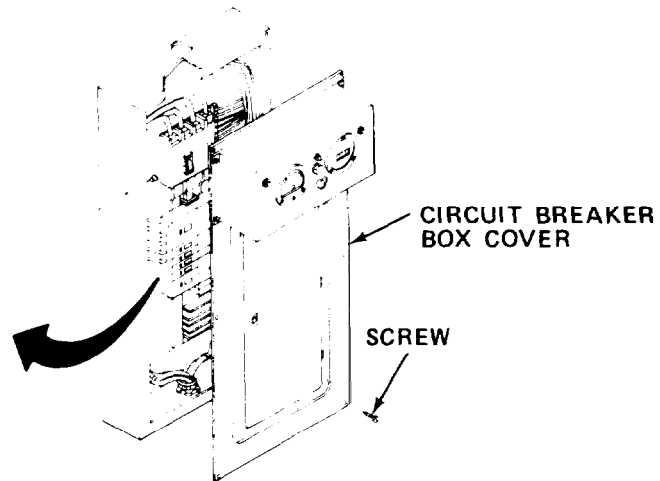
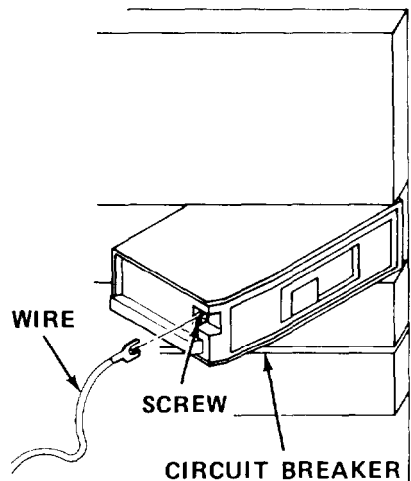

**WARNING**

Turn off and padlock safety switch. Turn off all individual circuit breakers before inspecting or servicing circuit breakers. Failure to do so may result in death or serious injury.

- a. Turn off and padlock safety switch. Turn off individual circuit breakers.
- b. Remove circuit breaker box cover.
- c. Use multimeter to make sure voltage is not present.
- d. Remove defective circuit breaker by pushing and snapping out of place.
- e. Tag and remove wires from defective circuit breaker.
- f. Pull circuit breaker from panel.
- g. Reconnect wires to new circuit breaker. Secure wires with screws.
- h. Install new circuit breaker by pushing and snapping into place.
- i. Reinstall circuit breaker box cover.
- j. Remove padlock and turn on safety switch and individual circuit breakers.

1-20.6 Repair Floor Covering.

MOS: 52C, Utilities Equipment Repairer

TOOLS: Utility Knife  
Cross Tip Screwdriver  
Scraper  
Straightedge

SUPPLIES: Vinyl Floor Covering  
Epoxy Resin (Item 15, Appendix E)  
Floor Patch (Item 8, Appendix E)  
Cheesecloth (Item 5, Appendix E)  
Adhesive (Item 1, Appendix E)

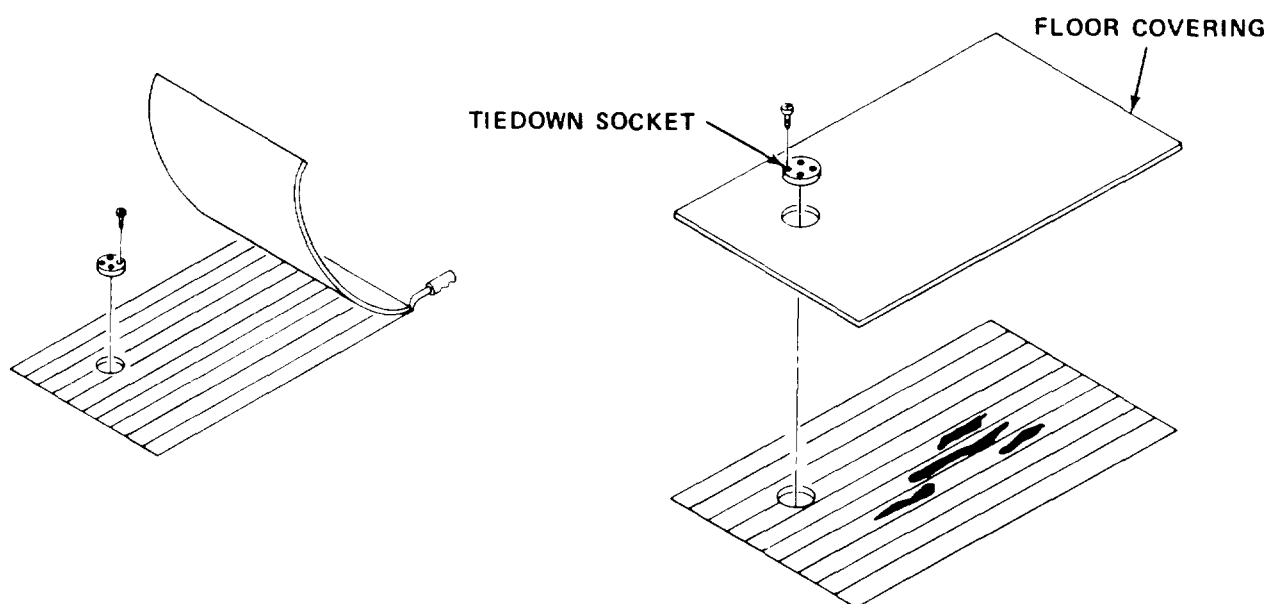

- a. Cut a rectangular area from damaged floor covering.
- b. Remove tiedown socket. Remove damaged floor covering.
- c. Cut new floor covering to fit. Apply adhesive to floor. Press down new floor covering.
- d. Reinstall tiedown socket.

1-20.7 Repair Van Body Skin (Permanent).

MOS: 63W, Wheel Vehicle Repairer

TOOLS: Pop Rivet Gun  
Electric Drill and Bits  
Paint Brush

SUPPLIES: Pop Rivets  
Sprayfoam (Item 21, Appendix E)  
Silicone Sealant (Item 17, Appendix E)  
Sheet Metal  
Paint (Items 11, 11A and 11B, Appendix E)  
Cheesecloth (Item 5, Appendix E)

- a. Bend broken edges of skin inward into puncture hole. Do not attempt to remove fragments of skin by bending or pulling out.
- b. Remove any loose fragments of foam.
- c. Use cloth dampened with water to clean area around puncture. Wipe dry.
- d. Inject sprayfoam into puncture. Fill to 1/8 in. (3.2mm) above surface of unbroken skin. Apply sealant to cracks leading to puncture.

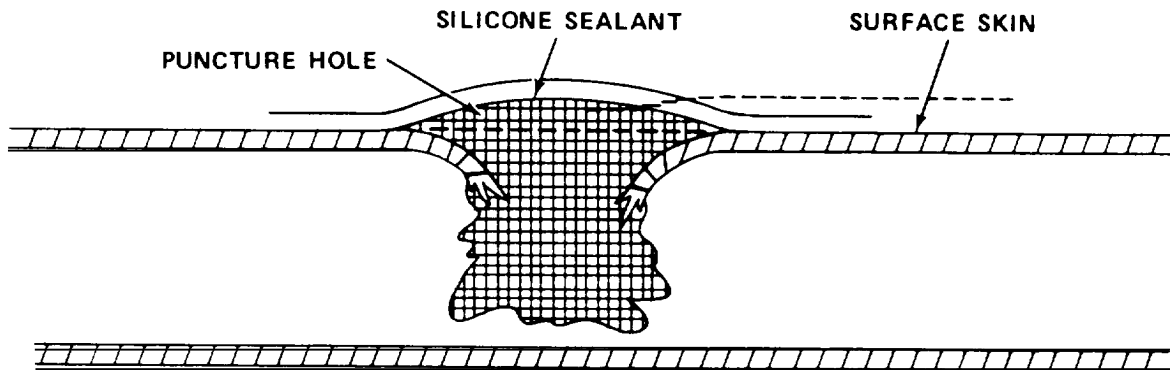
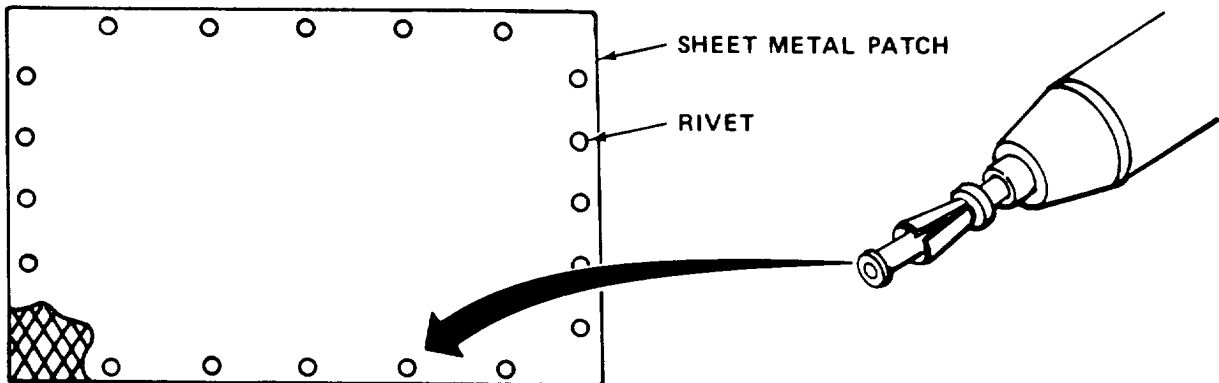

- e. Prepare sheet metal patch large enough to cover damaged area with overlap.
- f. Place patch over damaged area and mark all around edges of patch.
- g. Drill holes 1 in. (25.4 mm) apart.
- h. Apply sealant to edges of patch.
- i. Apply patch to van body.
- j. Install pop rivets beginning at center of each side. Rivets should be placed 1 in. (25.4 mm) apart.
- k. Paint as needed.

1-20.8 Replace Air Conditioner/Heater.

MOS: 63W, Wheel Vehicle Repairer

PERSONNEL: Two persons are required to perform this procedure.

TOOLS: Cross Tip Screwdriver  
Lifting Equipment  
8 in. Adjustable Wrench  
7/16 in. Combination Wrench

SUPPLIES: Air Conditioner/Heater  
Solvent P-D-680 (Item 19, Appendix E)  
Gasket  
Silicone Sealant (Item 17, Appendix E)  
Adhesive (Item 2, Appendix E)

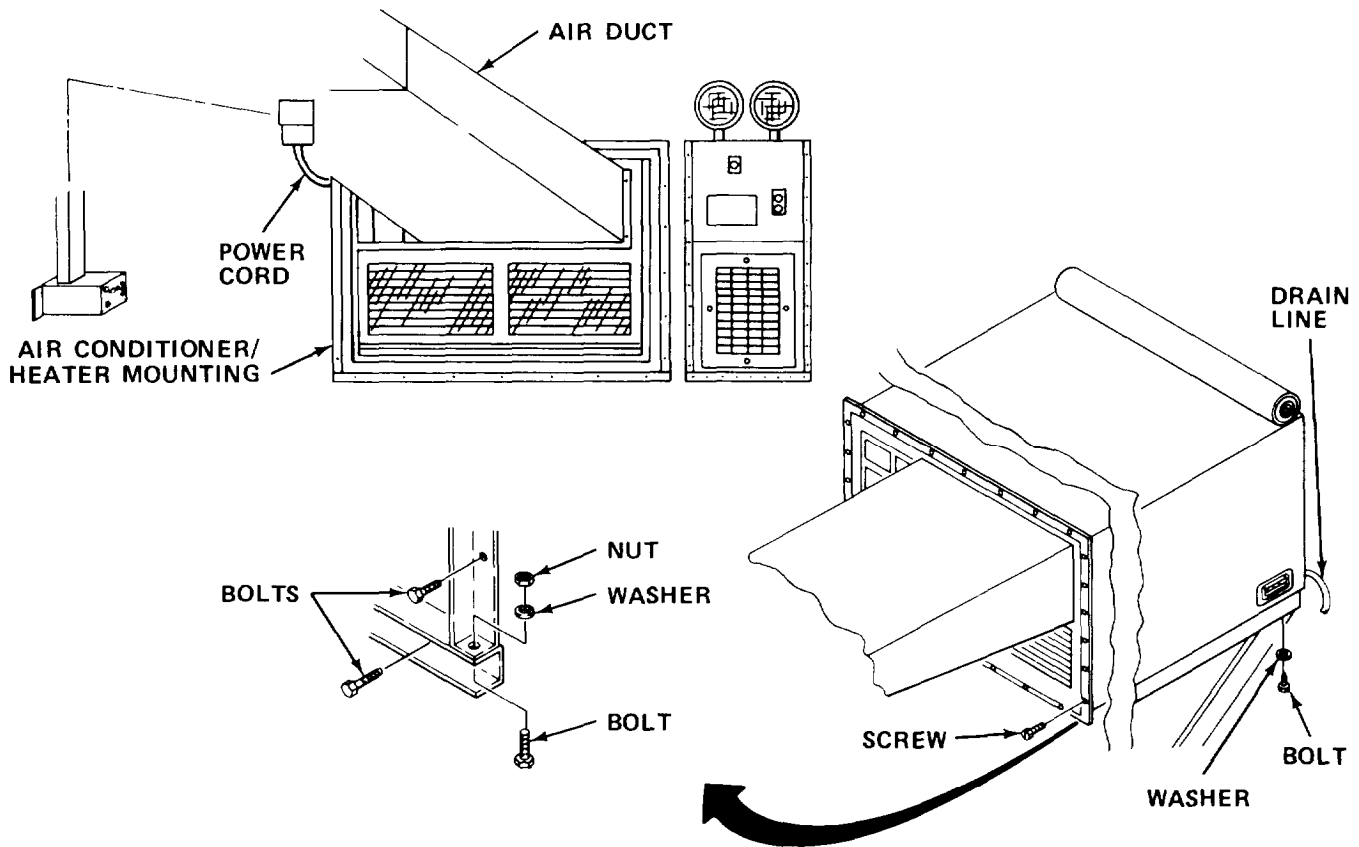

**WARNING**

- Use hoist or proper lifting equipment to replace air conditioner/heater. Failure to do so may result in death or serious injury.
- Turn off air conditioner/heater circuit breaker and unplug power cord. Failure to do so may result in death or serious injury.

- a. Turn off air conditioner/heater circuit breaker. Unplug or disconnect power cord as appropriate.
- b. Remove screws holding air duct to air conditioner/heater.
- c. Remove nut, washer, and screw from each corner of air conditioner/heater mounting. Remove screws securing mounting to section.
- d. Disconnect drain line from air conditioner/heater.
- e. Attach sling to lifting handles. Raise hoist enough to remove slack from sling.
- f. Remove mounting bolts and washers.
- g. Slide out air conditioner until other lifting handles are free. Attach sling to handles.
- h. Raise defective air conditioner/heater with hoist until unit is free from brackets and section.
- i. Place air conditioner/heater on flat-bed truck or pallet.

**WARNING**

Dry cleaning solvent, P-D-680, used to clean parts is potentially dangerous to personnel and property. Avoid repeated and prolonged skin contact. Wear solvent-impermeable gloves and eye/face protective equipment when using solvent. Do not use near open flame or excessive heat. Flash point of solvent is 100°F to 138°F (38°C to 59°C).

- j. Clean sealant from opening using dry cleaning solvent P-D-680.
- k. Remove damaged gasket and replace with new gasket.
- l. Raise air conditioner/heater until it rests on air conditioner/heater brackets.
- m. Remove two sling hooks as unit is eased into hole until grille touches duct .
- n. Remove remaining sling.
- o. Reinstall washers and mounting bolts.
- p. Reconnect drain lines.
- q. Reinstall screws securing air conditioner/heater mounting to section wall. Reinstall screw, washer, and nut to each corner of mounting.
- r. Reinstall screws securing air duct to air conditioner/heater.
- s. Reconnect or plug in power cord. Turn on air conditioner/heater circuit breaker.

1-20.9 Replace Air Conditioner Support Bracket.

MOS: 63W, Wheel Vehicle Repairer

PERSONNEL: Two persons are required to perform this procedure,

TOOLS: 9/16 in. Combination Wrench  
Lifting Equipment  
Knife, TL-29

SUPPLIES: Air Conditioner Support Bracket  
Drain Tube Ties

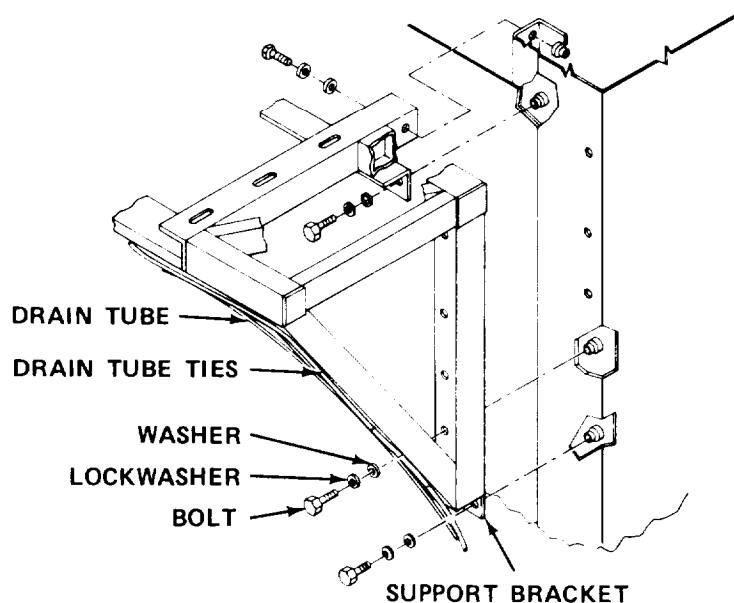

**WARNING**

Serious injury to personnel or damage to equipment may occur unless two or more personnel are used to remove and replace air conditioner/heater because of weight and balance of air conditioner/heater.

- a. Remove air conditioner/heater (paragraph 1-20.8).
- b. Cut drain tube ties and remove drain tube from support bracket.
- c. Remove bolts, lockwashers, and washers securing support bracket.
- d. Remove defective support bracket.
- e. Install new support bracket. Secure to section with bolts, lockwashers, and washers.
- f. Reinstall drain tube on support bracket, and secure with new ties.
- g. Reinstall air conditioner/heater (paragraph 1-20.8).



1-20.10 Replace Ventilation Duct.

MOS: 52C, Utilities Equipment Repairer

TOOLS: Hacksaw  
 Electric Drill and Bits  
 Ball Peen Hammer  
 Pop Rivet Gun  
 Paint Brush  
 Cross Tip Screwdriver

SUPPLIES: Silicone Sealant (Item 17, Appendix E)  
 Wood Block  
 Pop Rivets  
 Paint (Item 12, Appendix E)  
 Cheesecloth (Item 5, Appendix E)  
 Salvaged Ventilation Duct

- a. Turn off air conditioner/heater so air will not blow through duct.

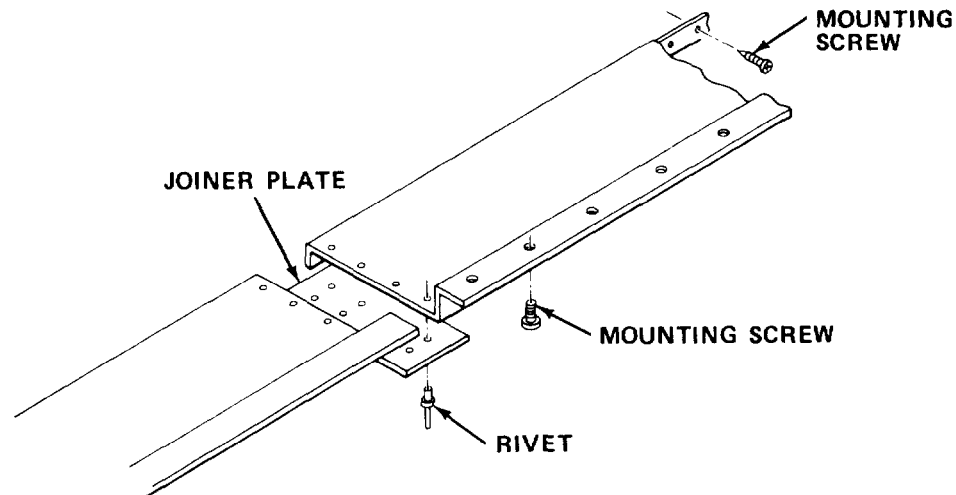

- b. Drill rivets from damaged section of duct. Remove joiner plates.  
 c. Remove mounting screws to remove damaged sections of duct.  
 d. Straighten remaining sections of duct at edges using hammer and wood block.  
 e. Place sealant on mounting edges.  
 f. Install new duct section cut from salvaged duct. Secure with screws.  
 g. Reinstall joiner plates. Install rivets to secure.  
 h. Paint as necessary.  
 i. Turn on air conditioner/heater.





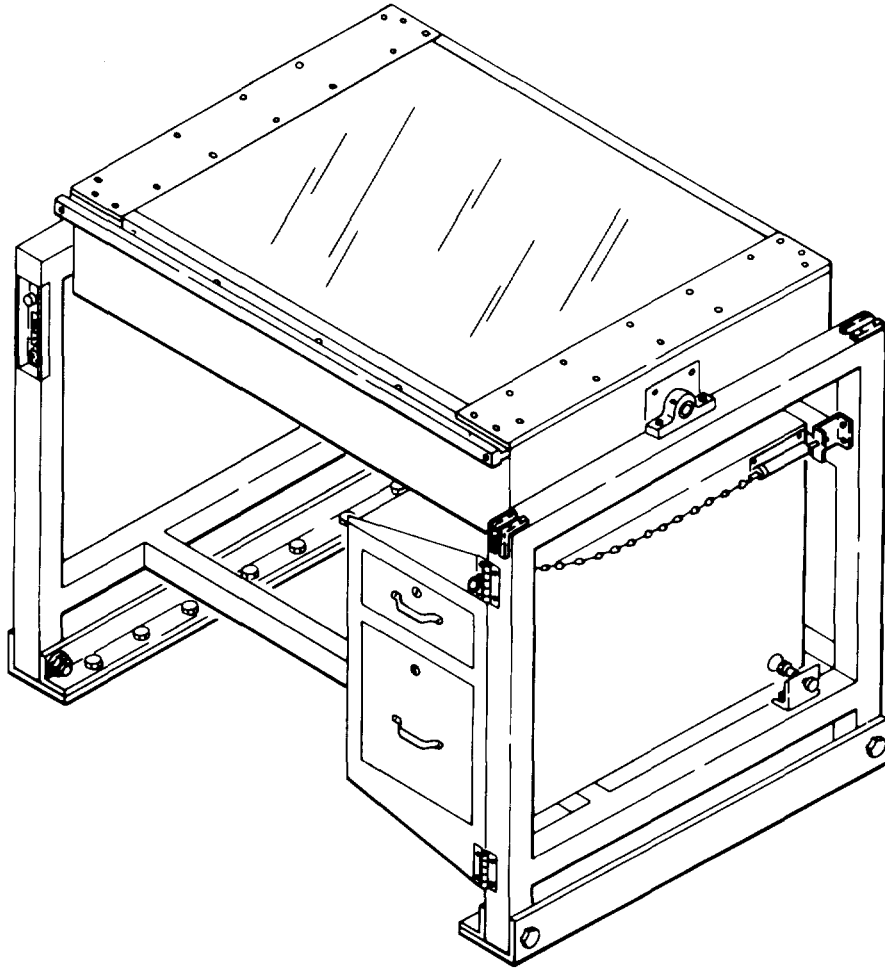

## CHAPTER 2

## DRAFTING, SCRIBING/TRACING TABLE

## Section I INTRODUCTION

**2-1. GENERAL INFORMATION.**2-1.1 Scope.

a. Model Number and Equipment Name. Model 99-9933 Drafting, Scribing/Tracing Table.

b. Purpose of Equipment. To provide user with drafting, scribing, or tracing table in compact unit.

**2-2. EQUIPMENT DESCRIPTION.**2-2.1 Equipment Characteristics, Capabilities, and Features.

- a. Rapid work surface selection.
- b. Auxiliary electrical outlets.
- c. Two drawer storage.
- d. Tilting work surface (0, 5, and 10 degrees).
- e. Easy access to all controls.
- f. Diffused light source.
- g. Drawing guard on front edge of drafting, scribing/tracing table.
- h. Sturdy steel base.

2-2.2 Location and Description of Major Components.

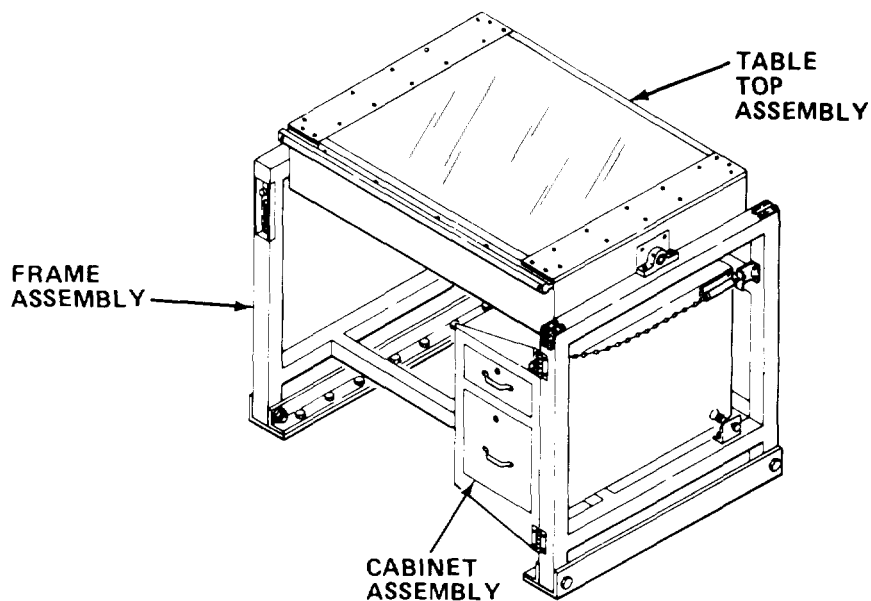

**FRAME ASSEMBLY.** Supports table top assembly, drawer assembly, control panel, safety stops, and tilt lock.

**TABLE TOP ASSEMBLY.** Consists of drafting board, light board, diffused lighting, and drawing guard.

**CABINET ASSEMBLY.** Consists of two drawers and drawer lock module.

2-2.3 Equipment Data.

Power Requirements	115 V, 60 Hz, single-phase
Drafting Surface	42 in. X 31 in. (106.7 cm X 78.7 cm)
Light Table Surface	30 in. X 30 in. (76.2 cm X 76.2 cm)
Dimensions	
Width	47 in. (119.4 cm)
Depth	34 in. (86.4 cm)
Height (Table Flat)	42 in. (106.7 cm)

2-3. TECHNICAL PRINCIPLES OF OPERATION.

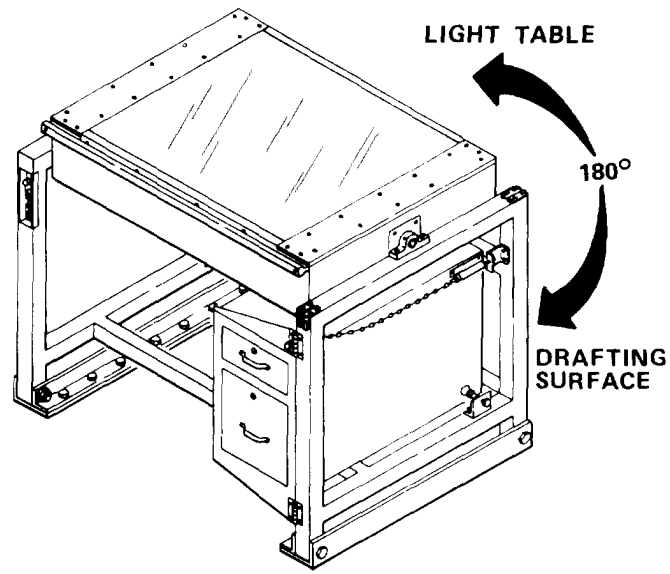

2-3.1 General. The movable top permits selection of drafting surface or light table, Has safety stops so that table top will turn only 180 degrees to prevent damage to electrical wiring. For drafting surface, rotate top away from operator. For light table, rotate top toward operator.

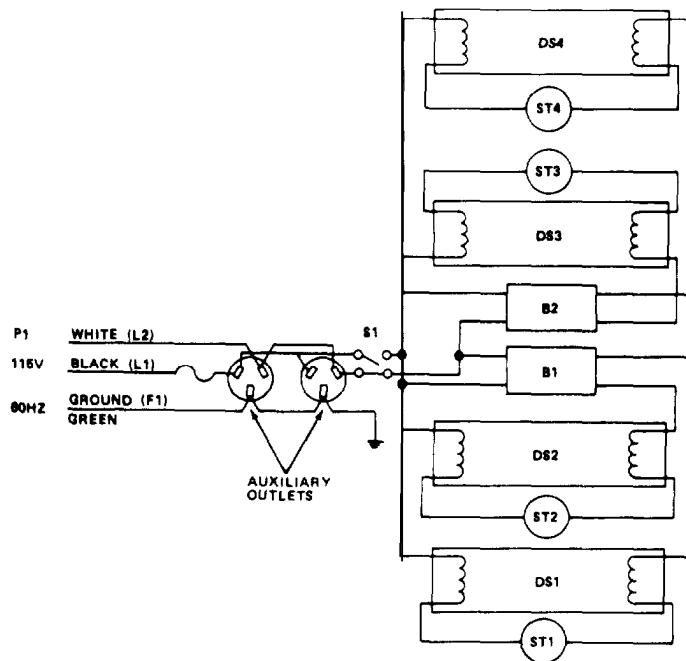

2-3.2 Electrical System. Provides power to the light table and two auxiliary outlets. The auxiliary outlets are located on the control panel. When plug P1 is connected, 120 V ac is applied to auxiliary outlets even if power switch S1 is off.

Section II OPERATING INSTRUCTIONS

2-4. DESCRIPTION AND USE OF OPERATOR'S CONTROLS AND INDICATORS.

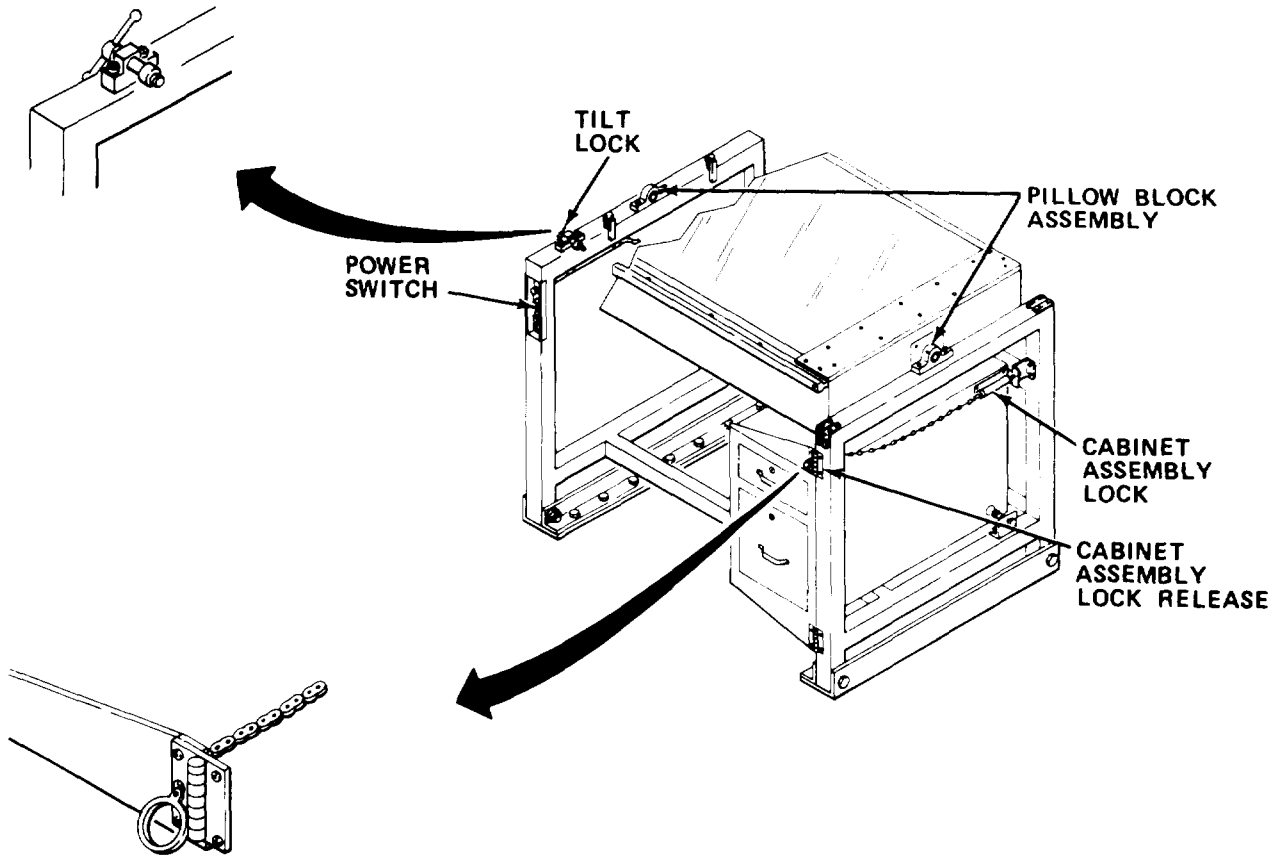

Control or Indicator	Function
Tilt Lock	Used to change angle of work surface or to change work surface. Loosen tilt lock to change work surface. Tighten to secure in position.
Pillow Block Assembly	Houses the bearing which allows easy rotation of the work surface.



Control or Indicator	Function
Cabinet Assembly Lock and Cabinet Assembly Lock Release	Located at upper cabinet assembly hinge on right front table leg. To open cabinet assembly, pull cabinet assembly lock release and swing assembly out, so it is not under table.
Power Switch	Provides power to light table lamps only.

## 2-5. OPERATOR PREVENTIVE MAINTENANCE CHECKS AND SERVICES.

- a. Before You Operate. Always keep in mind the WARNINGS and CAUTIONS. Perform your before (B) PMCS.
- b. While You Operate. Always keep in mind the WARNINGS and CAUTIONS. Perform your during (D) PMCS.
- c. After You Operate. Be sure to perform your after (A) PMCS.
- d. If Your Equipment Fails to Operate. Troubleshoot with proper equipment. Report any deficiencies using the proper forms. See DA Pam 738-750.

### 2-5.1 PMCS Procedures.

- a. PMCS are designed to keep the equipment in good working condition by performing periodic service tasks.
- b. Service intervals provide you, the operator, with time schedules that determine when to perform specified service tasks.
- c. The "Equipment is Not Ready/Available If" column is used for identification of conditions that make the equipment not ready/available for readiness reporting purposes or denies use of the equipment until corrective maintenance is performed.
- d. If your equipment fails to operate after PMCS is performed, immediately report this condition to your supervisor.
- e. Perform weekly as well as before operation if you are the assigned operator and have not operated the item since the last weekly or if you are operating the item for the first time.

f. Item number column. Item numbers are assigned in chronological ascending sequence regardless of interval designation. These numbers are used for your "TM Number" column on DA Form 2404, Equipment Inspection and Maintenance Worksheet in recording results of PMCS.

g. Interval columns. This column determines the time period designated to perform your PMCS.

h. Item to be inspected and procedures column. This column lists functional groups and their respective assemblies and subassemblies as shown in the Maintenance Allocation chart (Appendix B). The appropriate check or service procedure follows the specific item to be inspected.

i. Equipment is not ready/available if: column. This column indicates the reason or cause why your equipment is not ready/available to perform its primary mission.

j. List of tools and materials required for PMCS is as follows:

<u>Item</u>	<u>Quantity</u>
Liquid Detergent (Item 7, Appendix E)	ar
Cheesecloth (Item 5, Appendix E)	ar

Table 2-1. OPERATOR PREVENTIVE MAINTENANCE CHECKS AND SERVICES

NOTE

If the equipment must be kept in continuous operation, check and service only those items that can be checked and serviced without disturbing operation. Make the complete checks and services when the equipment can be shut down.

B - Before  
D - During  
A - After

W - Weekly  
M - Monthly  
Q - Quarterly

AN - Annually  
S - Semiannually  
BI - Biennially

(Number) - Hundreds of Hours

ITEM NO	INTERVAL	ITEM TO BE INSPECTED  PROCEDURE	For Readiness Reporting, Equipment Is Not Ready/ Available If:
1	B/P	<p><b>DRAFTING. SCRIBING/TRACING TABLE</b></p> <p><u>Inspect.</u></p> <ol style="list-style-type: none"> <li>Glass table surface.</li> </ol>  <ol style="list-style-type: none"> <li>Turn power switch OFF.</li> </ol>	Glass cracked or broken.

Table 2-1. OPERATOR PREVENTIVE MAINTENANCE CHECKS AND SERVICES - Cont

B - Before  
D - During  
A - After

W - Weekly  
M - Monthly  
Q - Quarterly

AN - Annually  
S - Semiannually  
BI - Biennially

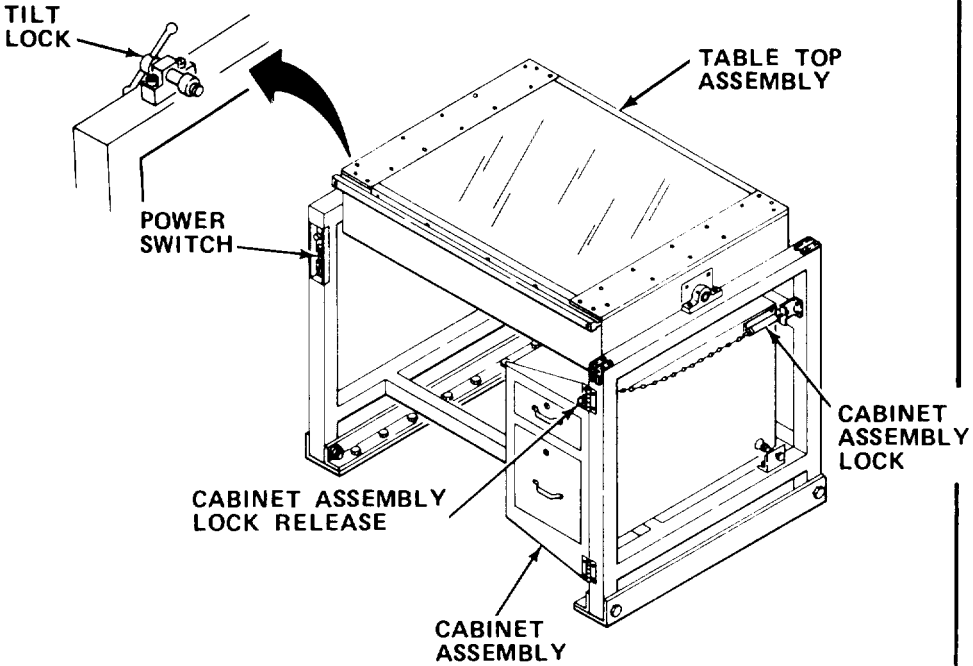
(Number) - Hundreds of Hours

ITEM NO.	INTERVAL	ITEM TO BE INSPECTED  PROCEDURE	For Readiness Reporting, Equipment Is Not Ready/ Available If:
1	B/A	<u>DRAFTING, SCRIBING/TRACING TABLE - Cont</u>	
		<u>Inspect - Cont</u>	
		3. Pull cabinet assembly lock release ring and swing out cabinet assembly.	
		4. Loosen tilt lock until it clears table top assembly.	
		5. Rotate table top 180°.	
		6. Tighten tilt lock to secure table top assembly in position.	
		7. Inspect wooden table top.	
		8. Rotate table top 180° and tighten tilt lock.	
		9. Return cabinet assembly to its normal position under table.	
		10. Press firmly on cabinet assembly front until cabinet assembly lock clicks.	
		11. Turn power switch ON. Be sure all table lights are on. Check surface for cracks or breaks.	
		12. Turn power switch OFF.	

Table 2-1. OPERATOR PREVENTIVE MAINTENANCE CHECKS AND SERVICES - Cont

B - Before  
D - During  
A - After

W - Weekly  
M - Monthly  
Q - Quarterly

AN - Annually  
S - Semiannually  
BI - Biennially

(Number) - Hundreds of Hours

ITEM NO	INTERVAL	ITEM TO BE INSPECTED  PROCEDURE	For Readiness Reporting, Equipment Is Not Ready/ Available If:
2	B	<p><u>DRAFTING, SCRIBING/TRACING TABLE - Cont</u></p> <p><u>Service.</u></p>  <p style="text-align: center;"><b>WARNING</b></p> <p>Death or serious injury may occur from electrical shock unless power cord is unplugged before servicing.</p> <ol style="list-style-type: none"> <li>1. Unplug power cord.</li> <li>2. Pull cabinet assembly lock release ring and swing out cabinet assembly.</li> <li>3. Loosen tilt lock until it clears table top assembly.</li> </ol>	

Table 2-1. OPERATOR PREVENTIVE MAINTENANCE CHECKS AND SERVICES - Cont

B - Before  
D - During  
A - After

W - Weekly  
M - Monthly  
Q - Quarterly

AN - Annually  
S - Semiannually  
BI - Biennially

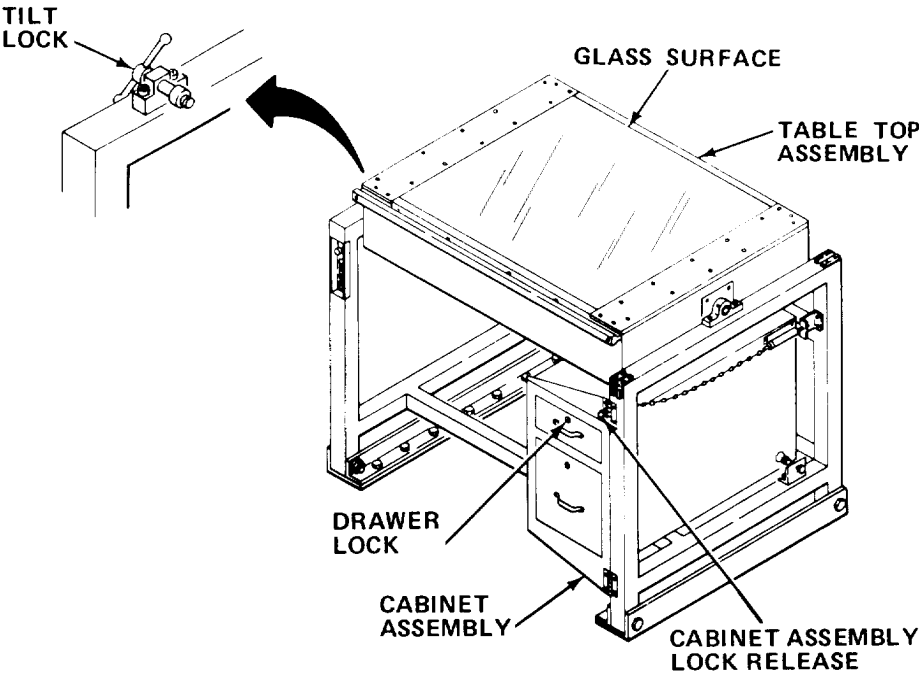
(Number) - Hundreds of Hours

ITEM NO.	INTERVAL	ITEM TO BE INSPECTED  PROCEDURE	For Readiness Reporting, Equipment Is Not Ready/ Available If:
2	B	<b>DRAFTING, SCRIBING/TRACING TABLE - Cont</b>	Table top does not rotate.
		<p data-bbox="277 527 508 555"><u>Service - Cont</u></p> <ol style="list-style-type: none"> <li data-bbox="277 591 1070 651">4. Rotate table top assembly until glass surface is on top.</li> <li data-bbox="277 719 1136 778">5. Tighten tilt lock to secure table top assembly in position.</li> </ol> <p data-bbox="637 810 769 838" style="text-align: center;"><b><u>CAUTION</u></b></p> <p data-bbox="365 874 1136 1034">Do not use abrasive cleaner on glass surface. Do not use running water or excessive water on cloth. Use moist cloth. Abrasive cleaner will scratch glass surface. Excessive water can cause equipment damage.</p> <ol style="list-style-type: none"> <li data-bbox="277 1102 1075 1161">6. Wipe glass surface with cheesecloth moistened in mild solution of detergent and water.</li> <li data-bbox="277 1193 1025 1253">7. Wipe glass surface with dry cheesecloth to remove streaks and smears.</li> <li data-bbox="277 1289 1080 1349">8. Swing cabinet assembly to its normal position under table.</li> <li data-bbox="277 1385 657 1412">9. Plug in power cord.</li> </ol>	

**2-6. OPERATION UNDER USUAL CONDITIONS.**2-6.1 Assembly and Preparation for Use.

- a. Clean work surface.
- b. Plug power cord into electrical receptacle.
- c. Turn power switch on for light table use.

2-6.2 Operating Procedures,

- a. Changing Work Surface.

**CAUTION**

Safety stops have been included to prevent overtravel of table top and damage to electrical wiring. If drafting surface is in top position, swing front edge of table top down to change work surface. If light table is in top position, swing front edge up to change work surface. Table cannot be rotated until cabinet assembly is swung out.

- (1) Pull cabinet assembly lock release ring and swing out cabinet assembly.
- (2) Loosen tilt lock until it clears table top assembly.
- (3) Tighten tilt lock to secure table top assembly in position.
- (4) Return cabinet assembly to its normal position under table top assembly.
- (5) Press firmly on cabinet assembly front until cabinet assembly lock clicks.

2-6.3 Preparation for Movement.

- a. Turn off power.
- b. Unplug power cord. Coil power cord and tape to table.
- c. Rotate table top assembly, if necessary, to be sure glass surface faces upward.
- d. Tighten tilt lock to secure table top assembly.
- e. Press firmly on cabinet assembly front until cabinet assembly lock clicks.
- f. Check cabinet drawers for open containers and loose items. Seal containers and secure all loose items.
- g. Lock cabinet drawers.

**2-7. OPERATION UNDER UNUSUAL CONDITIONS.** This equipment is designed for operation only in a controlled environment.

### Section III OPERATOR MAINTENANCE

#### 2-8. LUBRICATION INSTRUCTIONS.

##### NOTE

These lubrication instructions are mandatory.

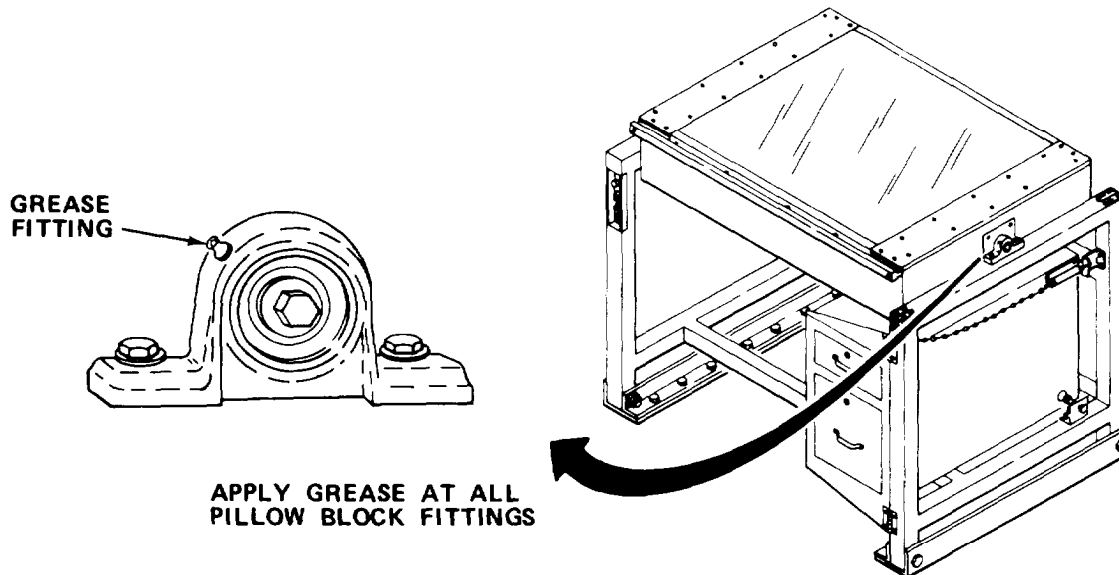

2-8.1 Pillow Block Fittings. Apply ball and roller bearing grease (Item 9, Appendix E) to both pillow blocks annually.

- a. Apply grease sparingly using grease gun.
- b. Wipe grease fittings clean after application.

#### 2-9. TROUBLESHOOTING PROCEDURES.

a. The table lists the common malfunctions which you may find during operation or maintenance of the drafting, scribing/tracing table, or its components. You should perform the test/inspections and corrective actions in the order listed.

b. This manual cannot list all malfunctions that may occur, nor all test or inspections and corrective actions. If a malfunction is not listed or is not corrected by listed corrective actions, notify your supervisor.



Table 2-2. TROUBLESHOOTING

---

MALFUNCTION
TEST OR INSPECTION
CORRECTIVE ACTION

---

1. LAMPS DO NOT LIGHT.

Step 1. Check that power switch is ON.

- (a) If power switch is ON, proceed to step 2.
- (b) Turn on power switch.

Step 2. Check that power cord is plugged in.

- (a) If power cord is plugged in, proceed to step 3.
- (b) Plug in power cord.

Step 3. Visually check fuse for broken filament.

- (a) Replace fuse (paragraphs 2-10.1)
- (b) If filament is not broken, refer to organizational maintenance.

2. TABLE DOES NOT LOCK.

Check for loose tilt lock.

- (a) If loose, tighten.
- (b) If tight, refer to organizational maintenance.

---

**2-10. MAINTENANCE PROCEDURES.**

This section contains instructions covering operator/crew maintenance functions for the drafting, scribing/tracing table. Personnel required are listed only if the task requires more than one.

b. After completing each maintenance procedure, perform operational check to be sure that equipment is properly functioning.

**INDEX**

PROCEDURE	PARAGRAPH
Replace Fuse . . . . .	2-10.1

**2-10.1 Replace Fuse.**

MOS: 81C, Cartographer

SUPPLIES: Fuse

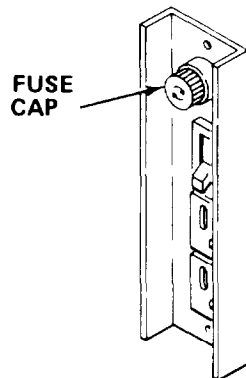

a. Turn power switch OFF.

**WARNING**

Death or serious injury may occur from electrical shock unless power cord is unplugged before servicing.

b. Unplug power cord.

c. Push in on cap and turn left.

d. Remove defective fuse.

e. Install new fuse, push in, and turn right.

f. Plug in power cord.

## Section IV ORGANIZATIONAL MAINTENANCE

### 2-11. LUBRICATION INSTRUCTIONS.

2-11.1 Pillow Block Fittings. After replacement, apply ball and roller bearing grease to pillow blocks (paragraph 2-8.1).

### 2-12. REPAIR PARTS, SPECIAL TOOLS; TEST, MEASUREMENT, AND DIAGNOSTIC EQUIPMENT (TMDE); AND SUPPORT EQUIPMENT.

2-12.1 Common Tools and Equipment. For authorized common tools and equipment, refer to the Modified Table of Organization and Equipment (MTOE) applicable to your unit.

2-12.2 Special Tools; Test, Measurement, and Diagnostic Equipment; and Support Equipment. Special Tools, TMDE, and Support Equipment is listed in the applicable repair parts and special tools list and in Appendix B of this manual.

2-12.3 Repair Parts. Repair parts are listed and illustrated in the Repair Parts and Special Tools List, TM 5-6675-313-24P covering organizational maintenance for this equipment.

**2-13. SERVICE UPON RECEIPT.** The drafting, scribing/tracing table may be received mounted in the section or in a shipping crate.

#### 2-13.1 Checking Unpacked Equipment.

a. Inspect the equipment for damage incurred during shipment. If equipment has been damaged, report the damage on DD Form 6, Packing Improvement Report.

b. Check the equipment against the packing list to see if the shipment is complete. Report all discrepancies in accordance with the instructions of DA Pam 738-750.

c. Check to see whether the equipment has been modified.

**2-14. ORGANIZATIONAL PREVENTIVE MAINTENANCE CHECKS AND SERVICES.** There are no organizational PMCS procedures assigned for this equipment.

**2-15. ORGANIZATIONAL TROUBLESHOOTING PROCEDURES.**

a. Organizational troubleshooting procedures cover the most common malfunctions that may be repaired at the organizational level. Repair or adjustment requiring specialized equipment is not authorized unless such equipment is available. Troubleshooting procedures used by the operator should be conducted in addition to the organizational troubleshooting procedures.

b. This manual cannot list all the possible malfunctions or every possible test/inspection and corrective action. If a malfunction is not listed or corrected by a listed corrective action, notify your supervisor.

c. For unidentified malfunctions, use the following schematic or foldout located at the end of this manual for further fault analysis.

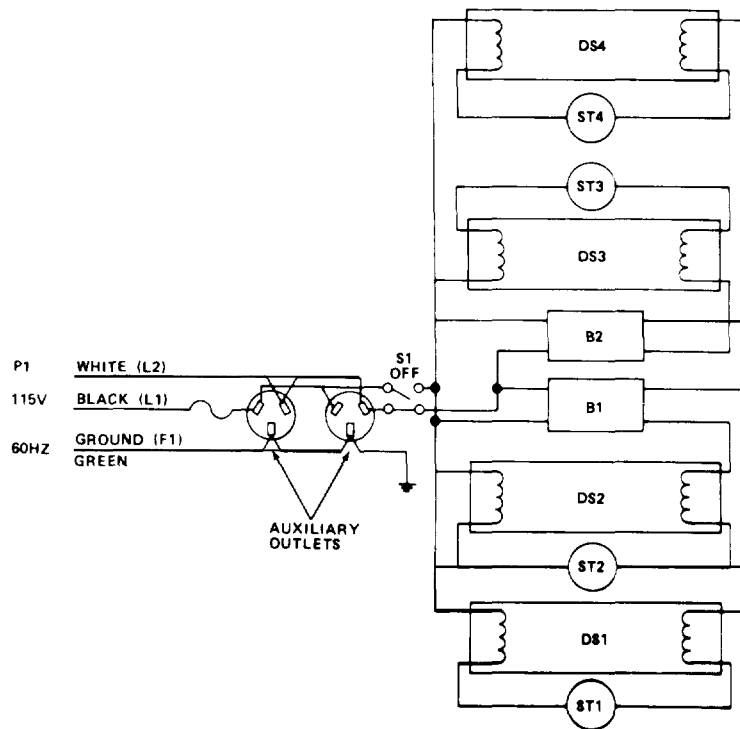

d. If the drafting, scribing/tracing table does not power-up when turned on, verify that 120 V ac is present at the receptacle. If voltage is not present, plug equipment into receptacle with power available and proceed with equipment troubleshooting. Perform no-power procedures for dead receptacle (Table '1-4).

Table 2-3. ORGANIZATIONAL TROUBLESHOOTING

MALFUNCTION	TEST OR INSPECTION	CORRECTIVE ACTION
1. LAMPS DO NOT LIGHT.	Step 1. Check continuity of power switch.	(a) If continuity exists, proceed to step 2. (b) If Continuity exists, replace power switch (paragraph 2-16.1).
	Step 2. Check continuity of power cord.	(a) If no continuity exists, replace power cord (paragraph 2-16.2). (b) If continuity exists, replace tube starter (paragraph 2-16.5). (c) If lamps still do not light, replace ballast (paragraph 2-16.4).
2. POWER RECEPTACLES DO NOT WORK.	Step 1. Check continuity of power cord.	(a) If continuity exists, proceed to step 2. (b) If noc oontinuity exists, replace power cord (paragraph 2-16.2).
	Step 2. Check continuity of receptacle.	Repair receptacle (paragraph 2-16.3).
3. TABLE DOES NOT LOCK.	Step 1. Check for loose tilt lock.	(a) If tight, proceed to step 2. (b) Tighten tilt lock.

Table 2-3. ORGANIZATIONAL TROUBLESHOOTING - Cont

---

MALFUNCTION

TEST OR INSPECTION

CORRECTIVE ACTION

---

3. TABLE DOES NOT LOCK - Cont

Step 2. Check for defective tilt lock.

(a) If good, proceed to step 3.

(b) If defective, replace (paragraph 2-16.6).

Step 3. Check for loose tilt locking block.

(a) If tight, proceed to step 4.

(b) If loose, tighten.

Step 4. Check for defective tilt locking block.

(a) If good, proceed to step 5.

(b) If defective, replace (paragraph 2-16.6).

Step 5. Check for defective tilt lock plate.

If defective, replace (paragraph 2-16.6).

---

**2-16. MAINTENANCE PROCEDURES.**

a. This section contains instructions covering organizational maintenance functions for the drafting, scribing/tracing table. Personnel required are listed only if the task requires more than one.

b. After completing each maintenance procedure, perform operational check to be sure that equipment is properly functioning.

**INDEX**

PROCEDURES	PARAGRAPH
Replace Power Switch . . . . .	2-16.1
Replace Power Cord . . . . .	2-16.2
Replace Receptacle . . . . .	2-16.3
Replace Lamp Ballast . . . . .	2-16.4
Replace Lamp/Starter . . . . .	2-16.5
Repair Tilt Lock . . . . .	2-16.6
Replace Pillow Block Assembly . . . . .	2-16.7
Remove/Install Drafting, Scribing/Tracing Table . . . . .	2-16.8

2-16.1 Replace Power Switch.

MOS: 83FJ6, Reproduction Equipment Repairer

TOOLS: 5/64 in. Hex Head Key Wrench

SUPPLIES: Power Switch

**WARNING**

Death or serious injury may occur from electrical shock unless power cord is unplugged before servicing.

- a. Turn power switch OFF.
- b. Unplug power cord.

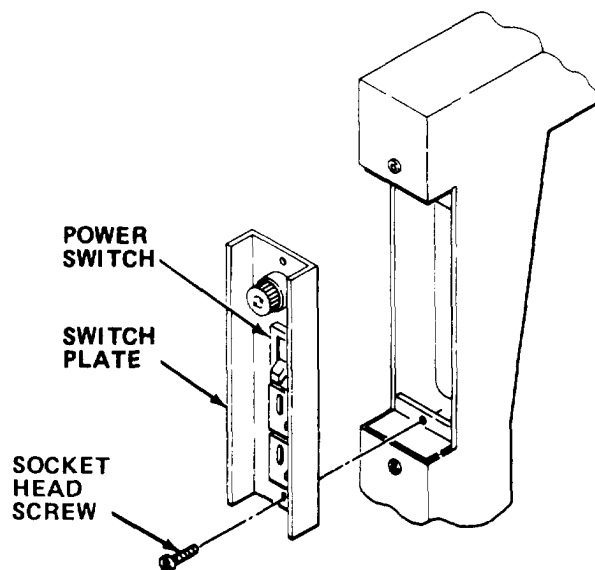

- c. Remove socket head screws and pull switch plate out.



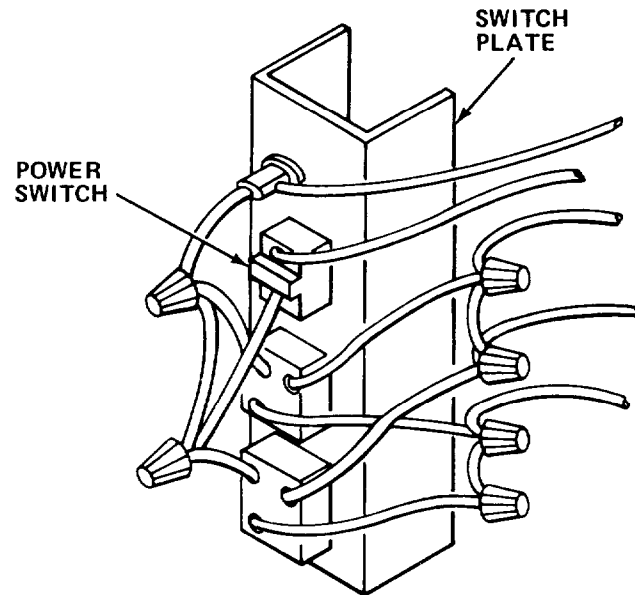

- d. Tag and disconnect wires from power switch.
- e. Remove defective power switch from front of switch plate.
- f. Install new power switch.
- g. Reconnect wires to power switch and remove tags.
- h. Reinstall switch plate and secure with socket head screws.
- i. Plug in power cord.

#### 2-16.2 Replace Power Cord.

MOS: 83FJ6, Reproduction Equipment Repairer

TOOLS: Flat Tip Screwdriver  
Soldering Iron  
5/64 in. Hex Head Key Wrench

SUPPLIES: Power Cord  
Solder (Item 18, Appendix E)

#### WARNING

Death or serious injury may occur from electrical shock unless power cord is unplugged before servicing.

- a. Turn power switch OFF.
- b. Unplug power cord.

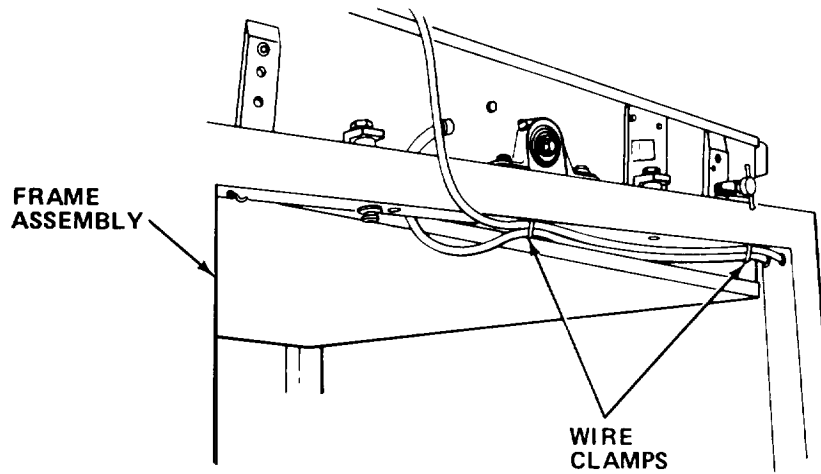

- c. Remove wire clamps located on frame assembly.

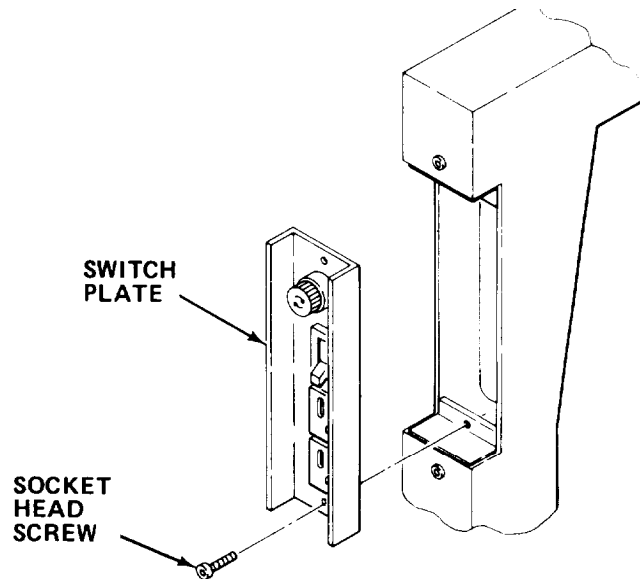

- d. Remove socket head screws and pull switch plate out.
- e. Tag wire connections for proper reconnection of wires.

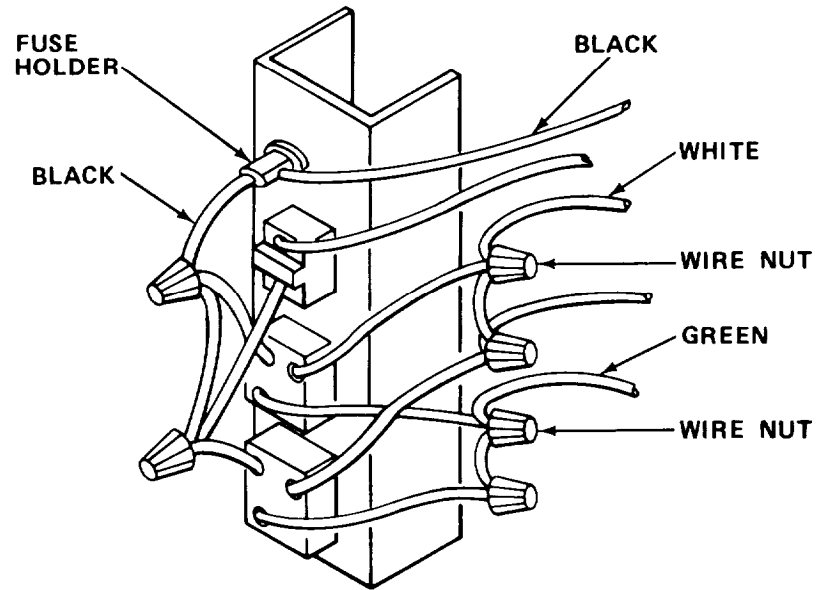

- f. Desolder black power cord lead from fuse holder.
- g. Disconnect white lead and green ground at wire nuts.
- h. Remove power cord.
- i. Insert new power cord through hole in back of leg.
- j. Reconnect white lead and green ground; tighten wire nuts.
- k. Solder black lead to fuse holder.
- l. Reinstall wire clamps.
- m. Reinstall switch plate and secure with socket head screws.
- n. Plug in power cord.

2-16.3 Replace Receptacle.

MOS: 83FJ6, Reproduction Equipment Repairer

TOOLS: Flat Tip Screwdriver  
5/64 in. Hex Head Key Wrench

SUPPLIES: Receptacle

**WARNING**

Death or serious injury may occur from electrical shock unless power cord is unplugged before servicing.

- a. Turn power switch OFF.
- b. Unplug power cord.

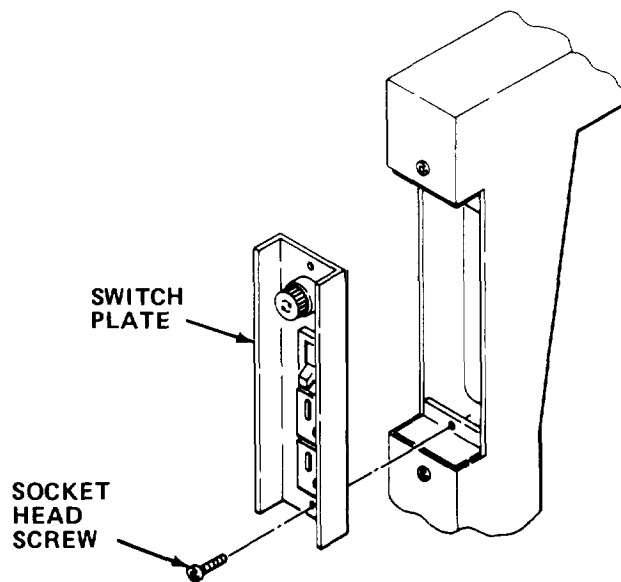

- c. Remove socket head screws and pull switch plate out.

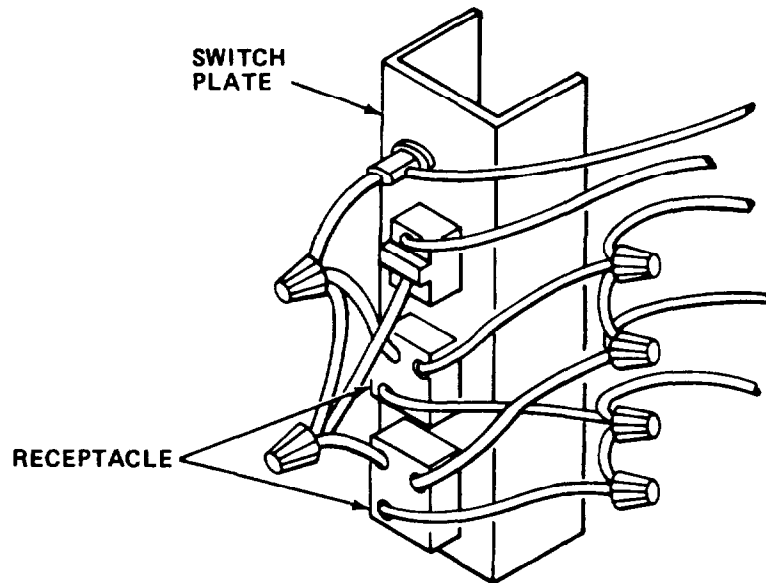

- d. Tag and disconnect wires from defective receptacle.
- e. Remove defective receptacle from switch assembly.
- f. Install new receptacle and reconnect wires.
- g. Reinstall switch plate and secure with socket head screws.
- h. Plug in power cord.

2-16.4 Replace Lamp Ballast.

MOS: 83FJ6, Reproduction Equipment Repairer

TOOLS: 3/32 in. Hex Head Key Wrench  
1/8 in. Hex Head Key Wrench  
1/4 in. Wrench  
3/8 in. Socket, 1/4 in. Drive  
1/4 in. Drive Ratchet

SUPPLIES: Lamp Ballast

**WARNING**

Death or serious injury may occur from electrical shock unless power cord is unplugged before servicing.

- a. Turn power switch OFF.
- b. Unplug power cord.

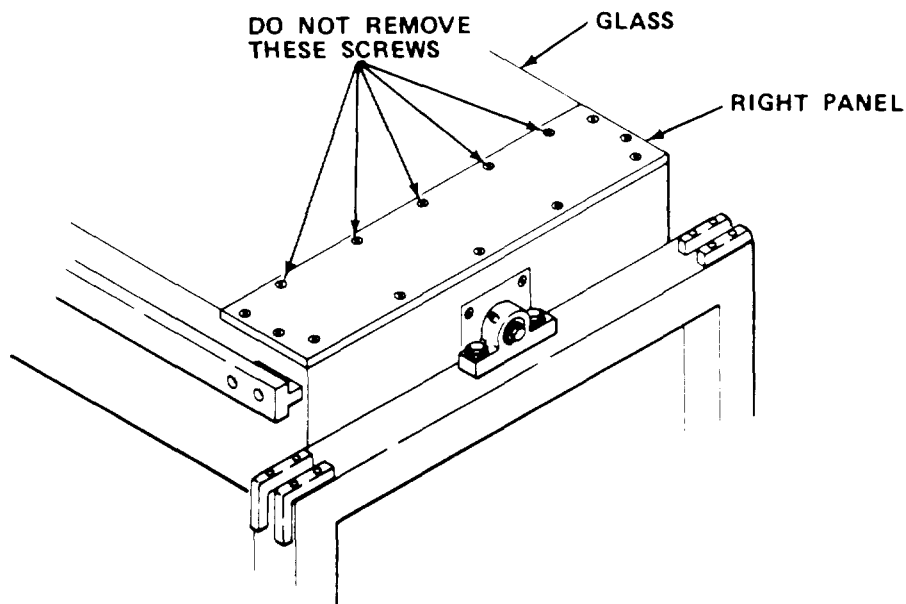

**CAUTION**

Removal of five socket head screws located closest to glass surface may result in damage to equipment.

- c. Remove nine socket head screws and right panel, but do not remove five socket head screws indicated in CAUTION and illustration.

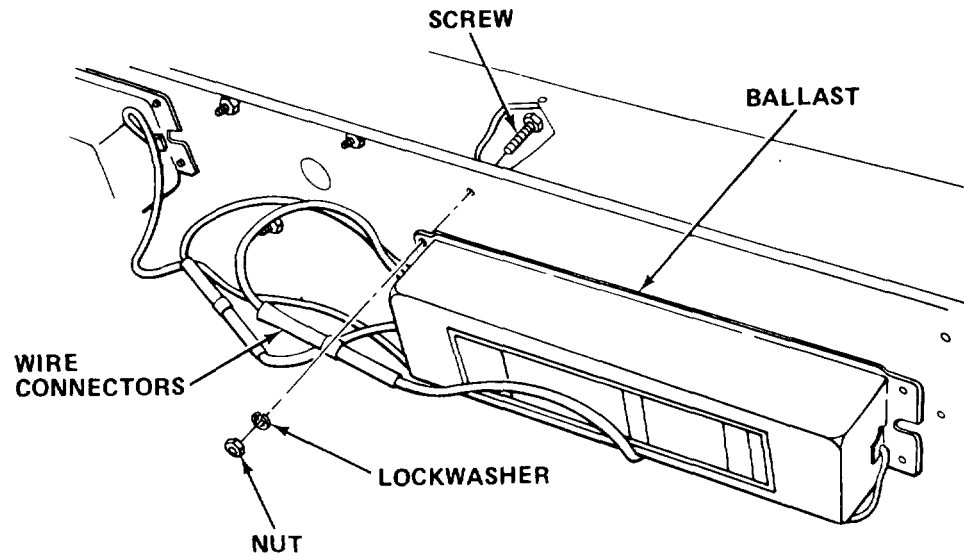

- d. Remove socket head screws, lockwashers, and nuts that secure ballast.
- e. Lift ballast out of table to gain access to wire connectors.
- f. Tag and disconnect all wires.
- g. Install new ballast.

#### NOTE

Be sure wires are not kinked.

- h. Reconnect all wires.
- i. Secure ballast with nuts, lockwashers, and socket head screws.
- j. Reinstall right panel and secure with socket head screws.
- k. Plug in power cord.

2-16.5 Replace Fluorescent Lamp/Starter.

MOS: 83FJ6, Reproduction Equipment Repairer

TOOLS: 3/32 in. Hex Head Key Wrench  
Flat Tip Screwdriver.

SUPPLIES: Fluorescent Lamp/Starter

**WARNING**

Death or serious injury may occur from electrical shock unless power cord is unplugged before servicing.

- a. Place light surface up. Turn on power switch and note defective lamp.
- b. Turn off power switch and unplug power cord.

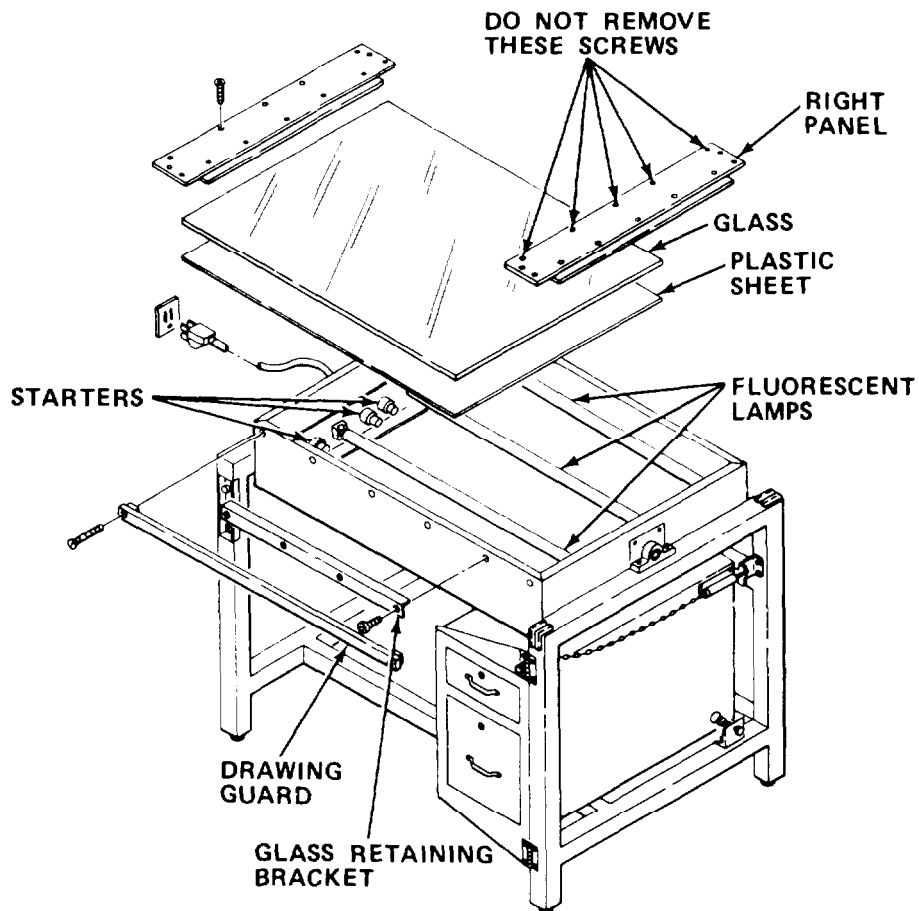



**CAUTION**

Removal of five socket head screws located closest to glass surface may result in equipment damage.

- c. Remove nine socket head screws and right panel, but do not remove five socket head screws indicated in CAUTION and illustration.
- d. Remove socket head screws and drawing guard.
- e. Remove socket head screws and glass retaining bracket.
- f. Carefully slide glass and plastic sheet from retaining glass bracket and left panel.
- g. Remove defective lamp/starter.
- h. Install new lamp/starter.
- i. Reinstall plastic sheet and glass.
- j. Reinstall right panel and secure with socket head screws.
- k. Reinstall glass retaining bracket and secure with socket head screws.
- l. Reinstall drawing guard and secure with socket head screws.
- m. Plug in power cord.

2-16.6 Repair Tilt Lock.

MOS: 83FJ6, Reproduction Equipment Repairer

TOOLS: Flat Tip Screwdriver  
7/16 in. Combination Wrench  
9 mm Wrench  
3/32 in. Hex Head Key Wrench  
3/16 in. Hex Head Key Wrench  
5/32 in. Hex Head Key Wrench

SUPPLIES: Tilt Lock Plate  
Limit Control Plate  
Safety Stop

**WARNING**

Death or serious injury may occur from electrical shock unless power cord is unplugged before servicing.

- a. Turn power switch OFF.
- b. Unplug power cord.

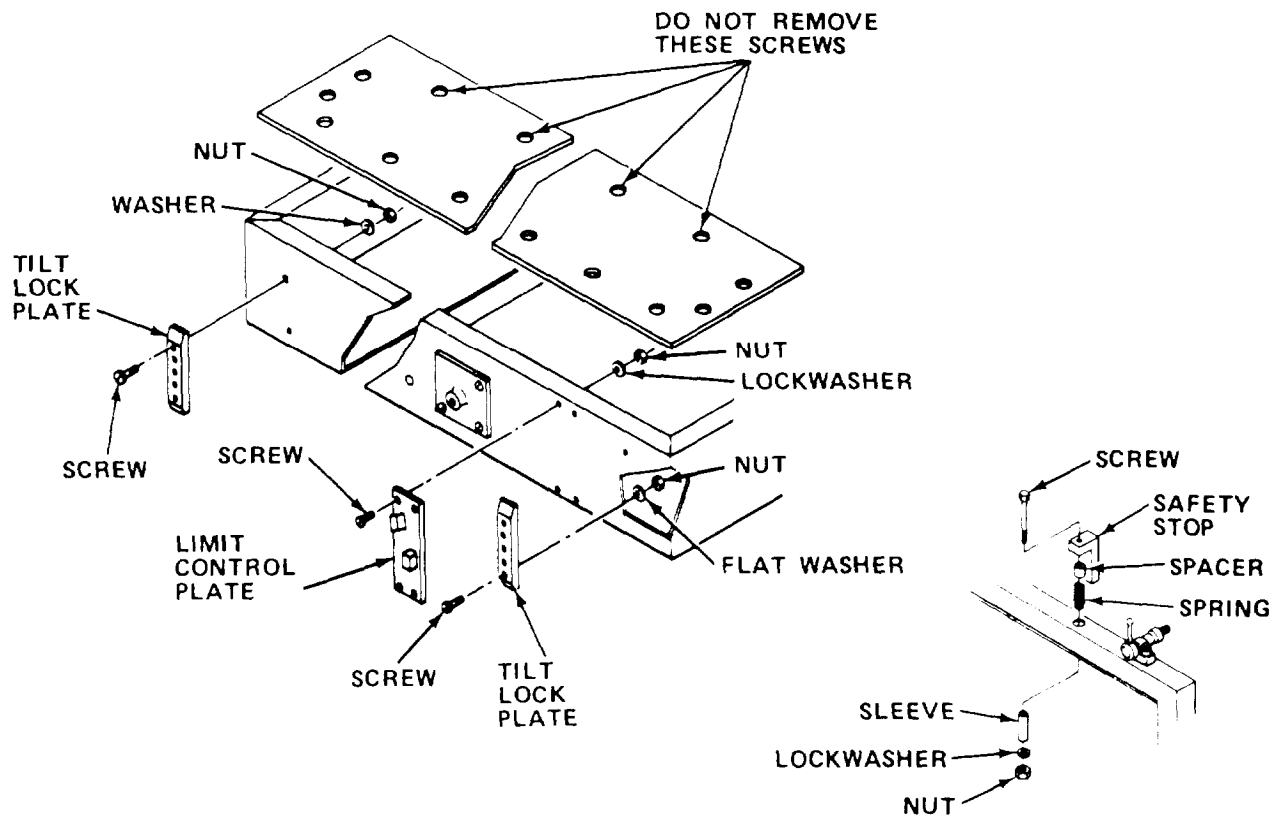

**CAUTION**

Removal of five socket head screws located closest to glass surface may result in damage to equipment.

- c. Remove nine socket head screws and left panel, but do not remove five socket head screws indicated in CAUTION and illustration.
- d. Pull cabinet assembly lock release and swing cabinet assembly out so that it is not under table.

**NOTE**

Tilt lock plates are not interchangeable and must be replaced in same positions.

- e. Remove upper screws, nuts, and washers from defective tilt lock plate.
- f. Tilt table top as necessary and remove defective tilt lock plate by removing lower screws, nuts, and washers.
- g. Install new tilt lock plate and secure with washers, nuts, and screws.
- h. Check position of tilt lock plate and readjust if required.
- i. Remove defective limit control plate by removing screws, washers, and nuts.
- j. Install new limit control plate. Secure with nuts, washers, and screws.
- k. Reinstall left panel and secure with nine socket head screws.

**NOTE**

Use care in disassembly of safety stop to prevent spring from falling inside frame.

- l. Remove defective safety stop by removing nut, lockwasher, sleeve, spring, spacer, and screw.
- m. Install new safety stop. Secure with screw, spacer, spring, sleeve, lockwasher, and nut.
- n. Swing cabinet assembly to its normal position under table.
- o. Plug in power cord.

2-16.7 Replace Pillow Block Assembly.

MOS: 83FJ6, Reproduction Equipment Repairer

TOOLS: 1/8 in. Hex Head Key Wrench.  
9/16 in. Combination Wrench  
1/2 in. Combination Wrench  
Grease Gun

SUPPLIES: Pillow Block Assembly  
GAA Grease (Item 9, Appendix E)

**WARNING**

Death or serious injury may occur from electrical shock unless power cord is unplugged before servicing.

- a. Turn power switch OFF.
- b. Unplug power cord.

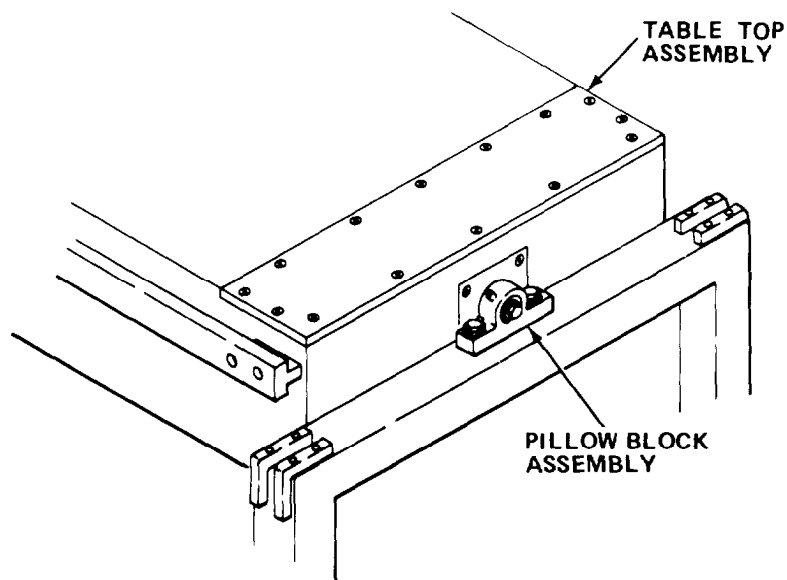

**CAUTION**

Table top assembly must be supported with drafting surface down to prevent table top from falling, causing equipment damage.

- c. Support table top assembly.

- d. Loosen, but do not remove socket head setscrew.

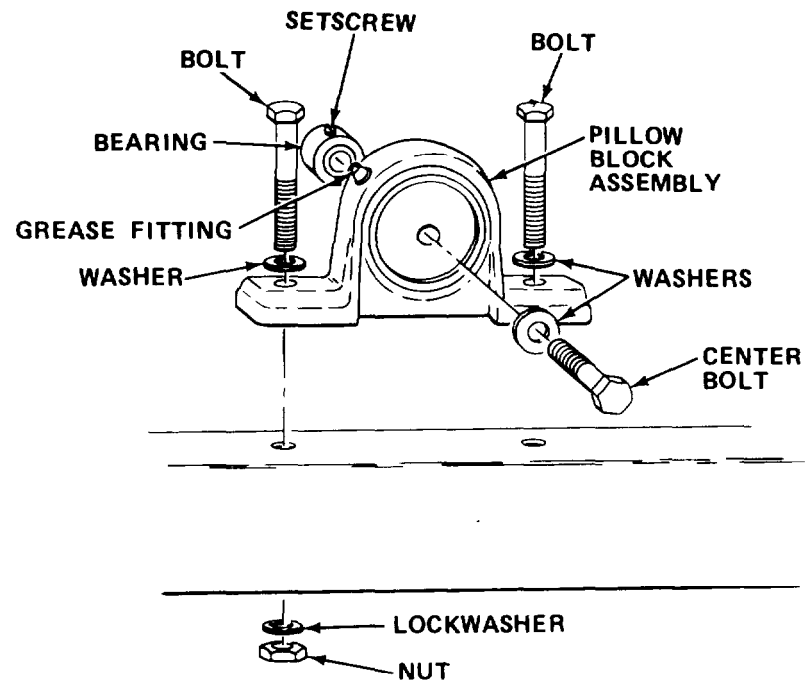

- e. Remove center bolt and washer.
- f. Remove bolts, washers, lockwashers, and nuts; remove defective pillow block assembly.
- g. Install new pillow block assembly and secure with nuts, lockwashers, washers, and bolts.
- h. Grease bearing (Paragraph 2-11.1).
- i. Reinstall washer and center bolt.
- j. Tighten socket head setscrew.
- k. Remove table top assembly supports.

2-16.8 Remove/Install Drafting, Scribing/Tracing Table.

MOS: 83FJ6, Reproduction Equipment Repairer

PERSONNEL: Two persons are required to perform this procedure.

TOOLS: 1/2 in. Combination Wrench

SUPPLIES: Drafting, Scribing/Tracing Table

**WARNING**

Death or serious injury may occur from electrical shock unless power cord is unplugged before servicing.

- a. Unplug power cord.
- b. Remove socket head screws, lockwashers, and nuts from table mounting brackets.

**WARNING**

To prevent personal injury, two persons are required to move the drafting, scribing/tracing table.

- c. Carefully pull table away from wall until it clears table mounting brackets.

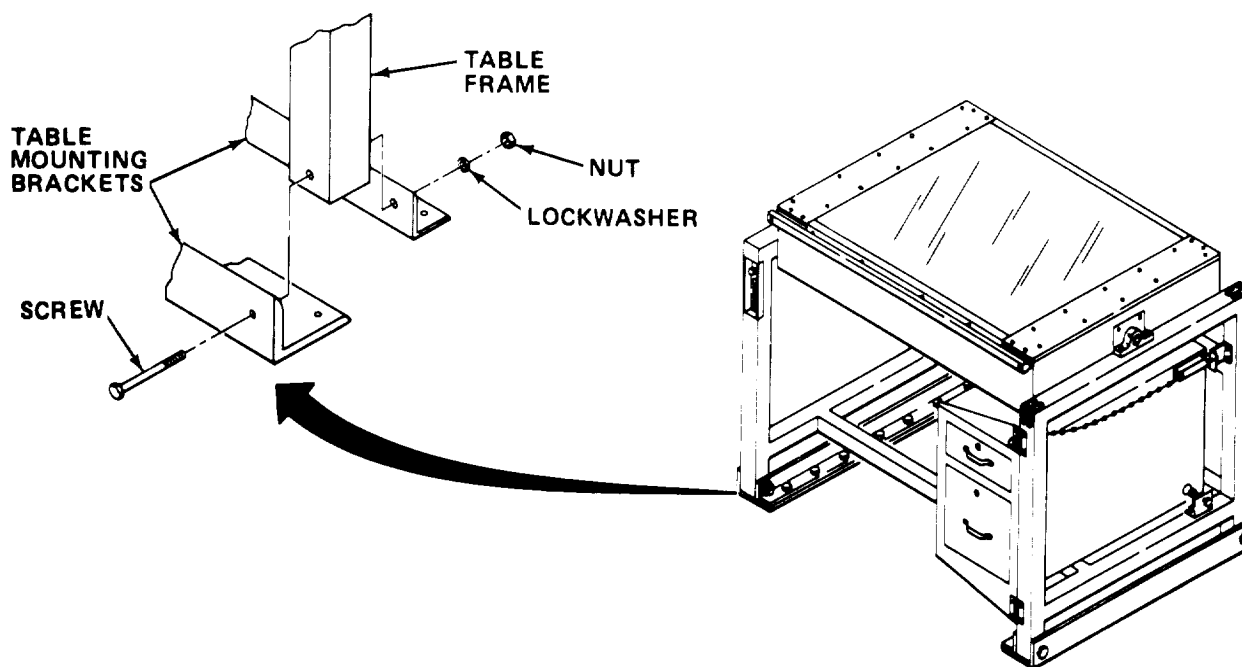

- d. Remove defective table from section.
- e. Position new drafting, scribing/tracing table in front of table mounting bracket.
- f. Slide table between table mounting brackets until holes in table frame are alined with table mounting bracket holes.
- g. Reinstall socket head screws, lock washers, and nuts into table mounting brackets.
- h. Plug in power cord.

**2-17. PREPARATION FOR STORAGE OR SHIPMENT.** Contact your battalion for packing and shipping instructions.

#### **Section V DIRECT/GENERAL SUPPORT MAINTENANCE**

There are no direct/general support maintenance procedures assigned for this equipment.







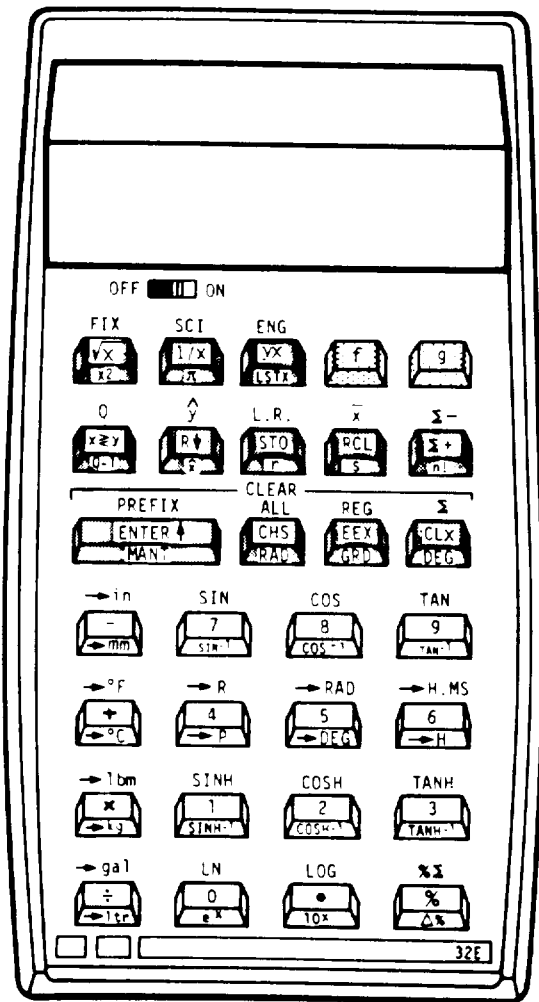

## CHAPTER 3

## POCKET CALCULATOR

## Section I INTRODUCTION

**3-1. GENERAL INFORMATION.**3-1.1 Scope.

- a. Model Number and Equipment Name. Model HP-32E Pocket Calculator.
- b. Purpose of Equipment. To perform mathematical calculations.

**3-2. EQUIPMENT DESCRIPTION.**

3-2.1 Equipment Characteristics, Capabilities, and Features. Performs mathematical calculations with the following capabilities and features.

- a. Rechargeable battery pack.
- b. AC operation.
- c. Trigonometric functions.
- d. Ten-digit display.
- e. Automatic memory stack.
- f. Fifteen storage registers.
- g. Scientific notation.
- h. Logarithmic functions.
- i. Square root.
- j. Fixed-point display.
- k. Engineering display.
- l. Automatic overflow and underflow.
- m. Error display.
- n. Key-selected metric conversions.
- o. Self-Check.

3-2.2 Equipment Data.

Power Requirements	120 V, 60 Hz
Battery Pack:	
Recharge Time	9 hrs, maximum (calculator off)
	17 hrs, minimum (calculator on)
Operating Time	3 hrs, maximum

**3-3. TECHNICAL PRINCIPLES OF OPERATION.** The purpose of the HP-32E Calculator is to assist its user in the performance of complex or simple mathematics equations and consists of the following functional parts:

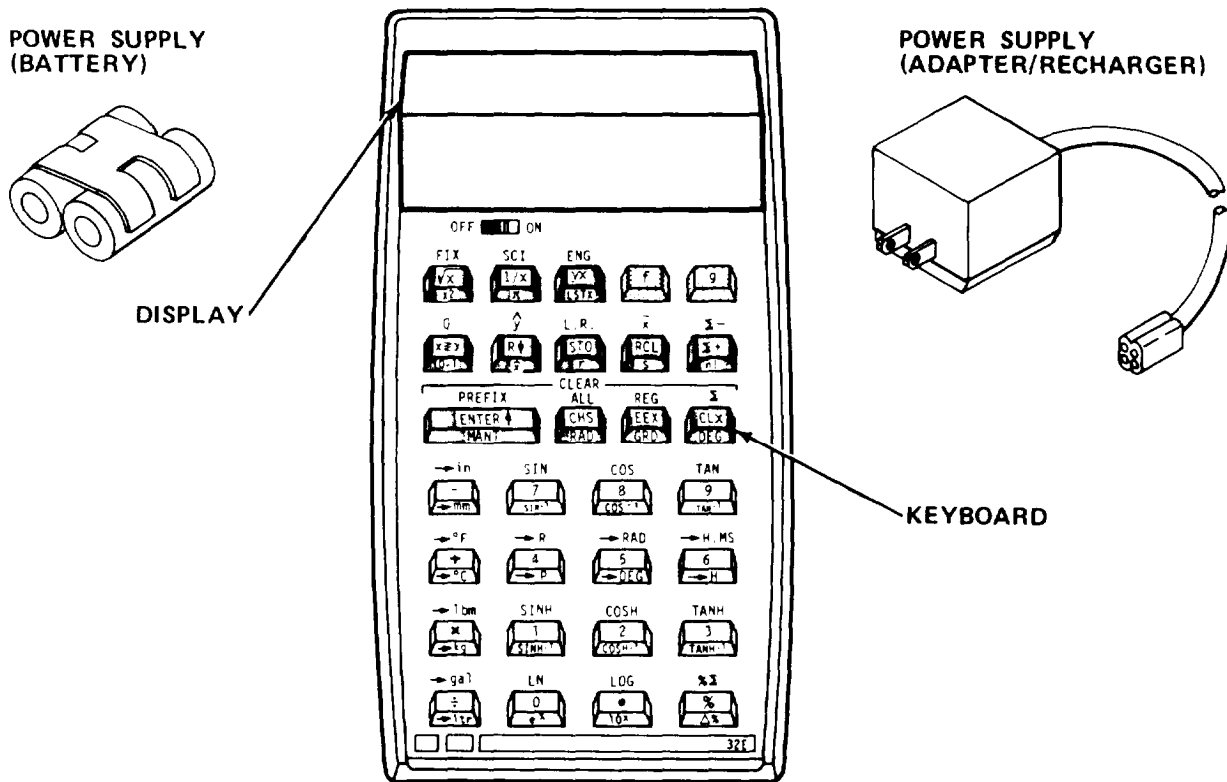

**POWER SUPPLY.** Power is provided to the calculator from either the battery pack or ac adapter/recharger. The battery pack consists of two rechargeable nickel cadmium batteries which give the calculator full portability. The adapter/recharger also provides power to the calculator when plugged into a power outlet. When battery pack is in need of recharging, raised decimal is turned on at the far left of the display. When raised decimal is displayed, there are 1 to 25 minutes of operating time left.

**KEYBOARD.** The keyboard is used to select functions and input numbers into the calculator. All keys, except **f** and **g** keys, perform three functions.

One function is indicated by the symbol on the flat surface of the key, a second by the symbol on the slanted key face, and a third by the symbol written above the key on the calculator case. Function printed on the flat face of the key is selected by pressing the key. Function printed above the key is selected by first pressing prefix key  $\boxed{f}$  and then the function key. The function printed on the slanted face of the key is selected by first pressing prefix key  $\boxed{g}$  and then the function key.

**DISPLAY.** The display is the X-register of the automatic memory stack and provides a visual readout of latest numeric entry, operation result, or error messages.

**MEMORY.** Memory is divided into two parts; storage registers and automatic memory stack.

a. **Storage registers.** Storage registers are used to set aside numbers for recall in later calculations. Numbers are stored by first pressing  $\boxed{STO}$  followed by a number  $\boxed{0}$  thru  $\boxed{8}$  or a decimal point and a number  $\boxed{0}$  thru  $\boxed{5}$ . The number in displayed X-register is then copied into the selected register. Recalling a number is accomplished by first pressing  $\boxed{RCL}$  followed by a number  $\boxed{0}$  thru  $\boxed{8}$  or a decimal point and a number  $\boxed{0}$  thru  $\boxed{5}$ . The number that is in the selected register will be copied into the displayed X-register without any change to contents of that register. Storage registers  $R_0$  through  $R_5$  are used for accumulation of statistical data. Turning calculator off will clear (place zeros in) all storage registers.

b. **Automatic memory stack.** The automatic memory stack is used to store intermediate results during calculations. The stack consists of four registers designated X, Y, Z and T. The contents of X-register are constantly shown on the calculator display. Numbers are manually entered into the memory stack by pressing  $\boxed{ENTER}$ . During chain calculations (long equations), intermediate answers are automatically entered in the memory stack. Each new entry into the stack is first entered in the X-register and, with each additional entry, the stack rolls up one and the contents that were in the T-register before roll-up, are lost. The contents of the stack can be viewed by pressing  $\boxed{RCL}$  key four times. The contents of T-register are not lost because the stack forms a continuous loop, i.e., the contents of T-register are shifted to the Z-register; Z-register to Y-register; Y-register to X-register; and X-register to T-register. With intermediate answers stored in the stack, operations can be performed with these numbers by pressing the key of the desired operation.

Example: To calculate  $(3 \times 5) + 2$ , press:

$\boxed{3}$  (3 enters X-register.)

$\boxed{ENTER}$  (3 is copied to Y-register.)

$\boxed{5}$  (5 is entered in X-register; 3 stays in Y-register.)

$\boxed{\times}$  (5 is multiplied by 3; result, 15, is placed in X-register; Y-register becomes 0.)

$\boxed{2}$  (15 moves to Y-register; 2 enters x-register.)

$\boxed{+}$  (2 is added to 15; result, 17, is placed in X-register; Y-register becomes 0.)

Section II OPERATING INSTRUCTIONS

3-4. DESCRIPTION AND USE OF OPERATOR'S CONTROLS AND INDICATORS.

NOTE

Symbols on flat surface and slanted surface of keys are boxed. Symbols over keys are not boxed.

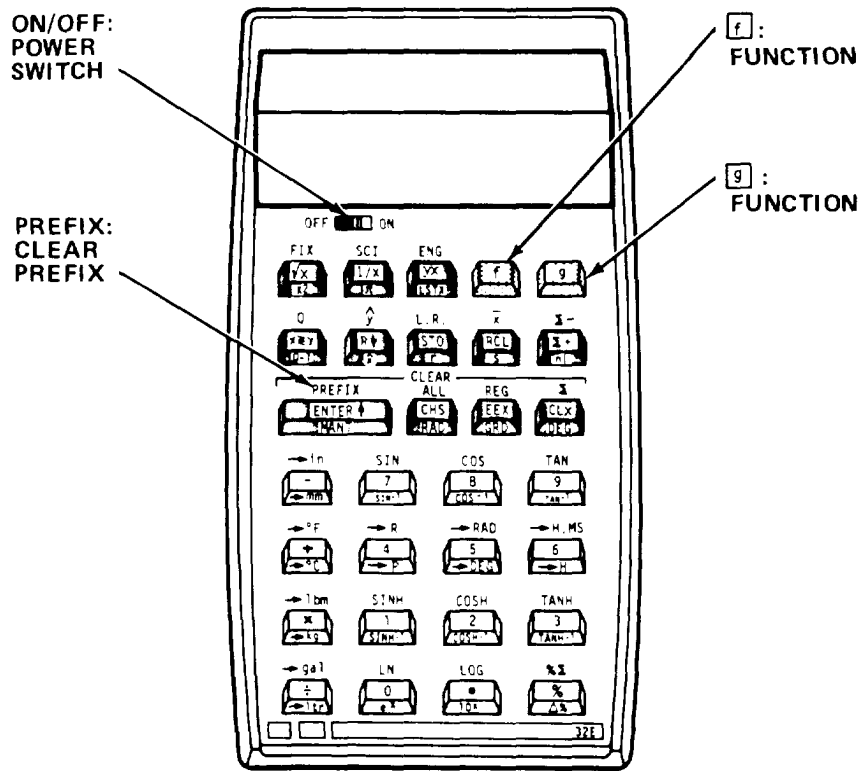

Key	Control or Indicator	Function
OFF ON	Power Switch	Turns power on or off.
f	Function	Pressed before another key, it selects function printed above key.
g	Function	Pressed before another key, it selects function printed on slanted face of key.

Key	Control or Indicator	Function
-----	----------------------	----------

PREFIX

Clear Prefix

Cancels the following key strokes or sequence of key strokes when pressed after each one:

$f$ ,  $g$ ,  $STO$ ,  $RCL$ ,  
 $STO$   $.$ ,  $RCL$   $.$ ,  
 $STO$   $+$ ,  $STO$   $-$ ,  
 $STO$   $\times$ ,  $STO$   $\div$ ,  
 $STO$   $+$   $.$ ,  
 $STO$   $-$   $.$ ,  
 $STO$   $\times$   $.$ ,  
 $STO$   $\div$   $.$ ,  
 FIX SCI, ENG.

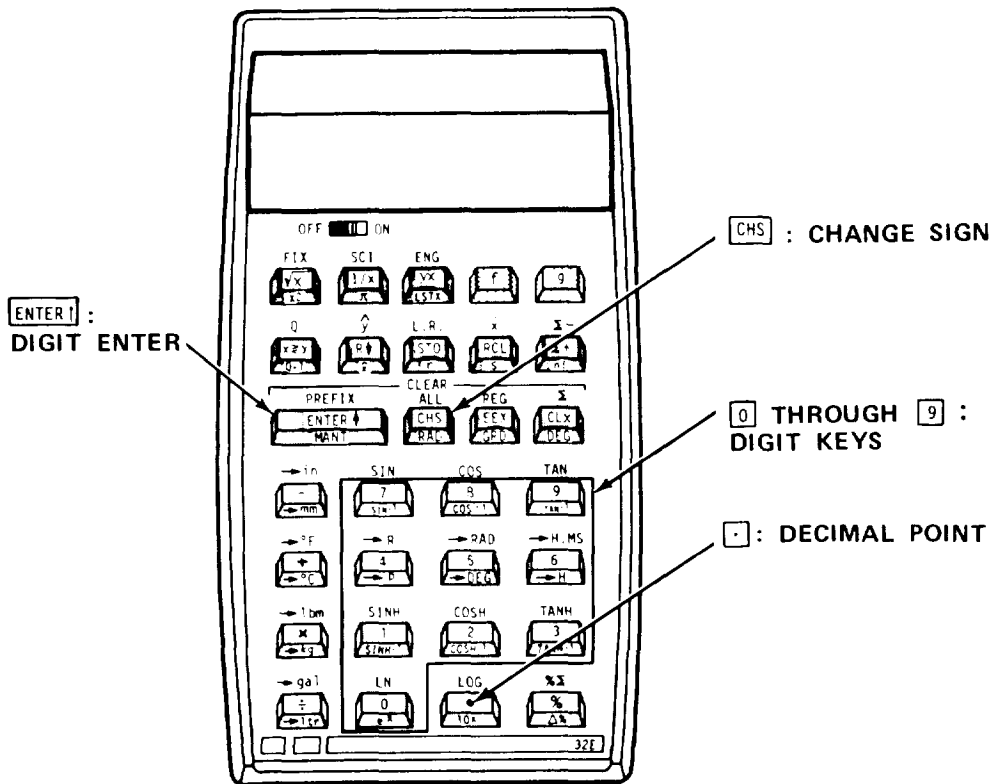

Digit Entry

$0$  thru  $9$

Digit Keys

Enters digits.

$.$

Decimal Point

Enters decimal point.

Key	Control or Indicator	Function
<b>ENTER</b>	Digit ENTER	Enters copy of number displayed in X-register into Y-register of automatic memory stack. Pressing key also causes contents of Y-register to be shifted to Z-register and Z-register to the T-register. Contents of T-register are lost.
<b>CHS</b>	Change Sign	Changes sign of mantissa or exponent in display (X-register).

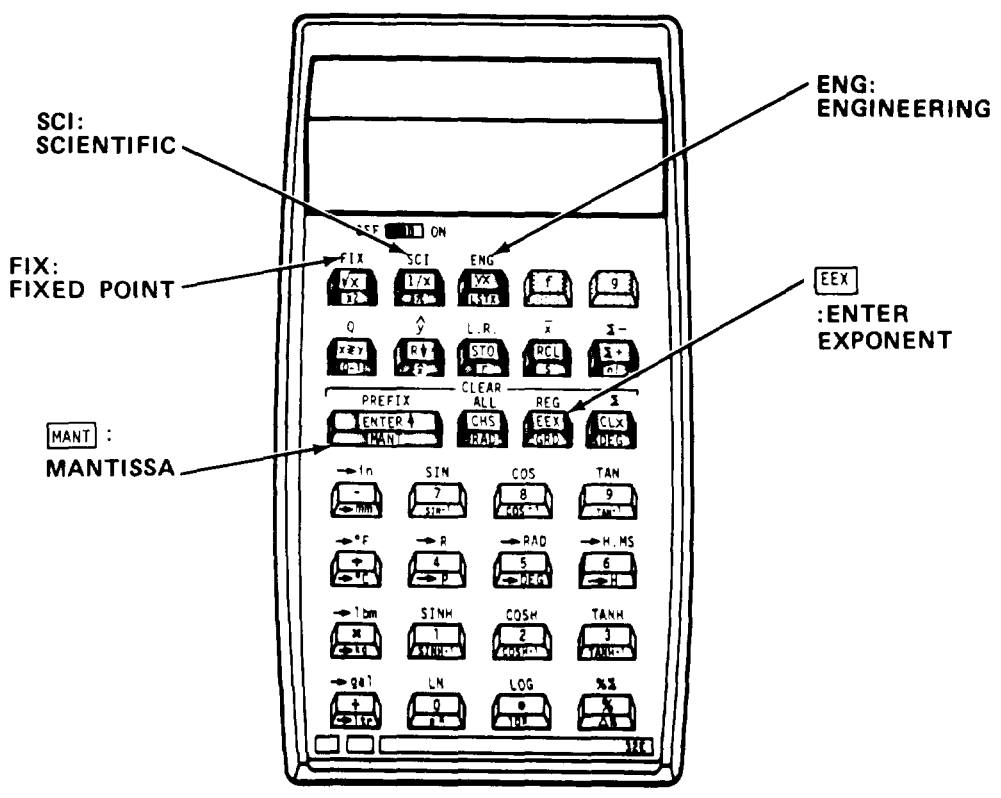

**Display Control**

Enter Exponent

After pressing, next numbers keyed in are exponents of 10.



---

Key	Control or Indicator	Function
FIX	Fixed Point	Followed by digit key, selects fixed point notation display. Digit entry designates number of digits to be displayed to the right of decimal point.
SCI	Scientific	Followed by the number key that specifies the number of decimal places the display will be rounded to.
ENG	Engineering	Followed by digit key, selects engineering notation display. Digit key specifies number of digits to be displayed to right of decimal point.
<span style="border: 1px solid black; padding: 2px;">MANT</span>	Mantissa	Temporarily displays all 10 digits of mantissa of number in X-register.

Key	Control or Indicator	Function
-----	----------------------	----------

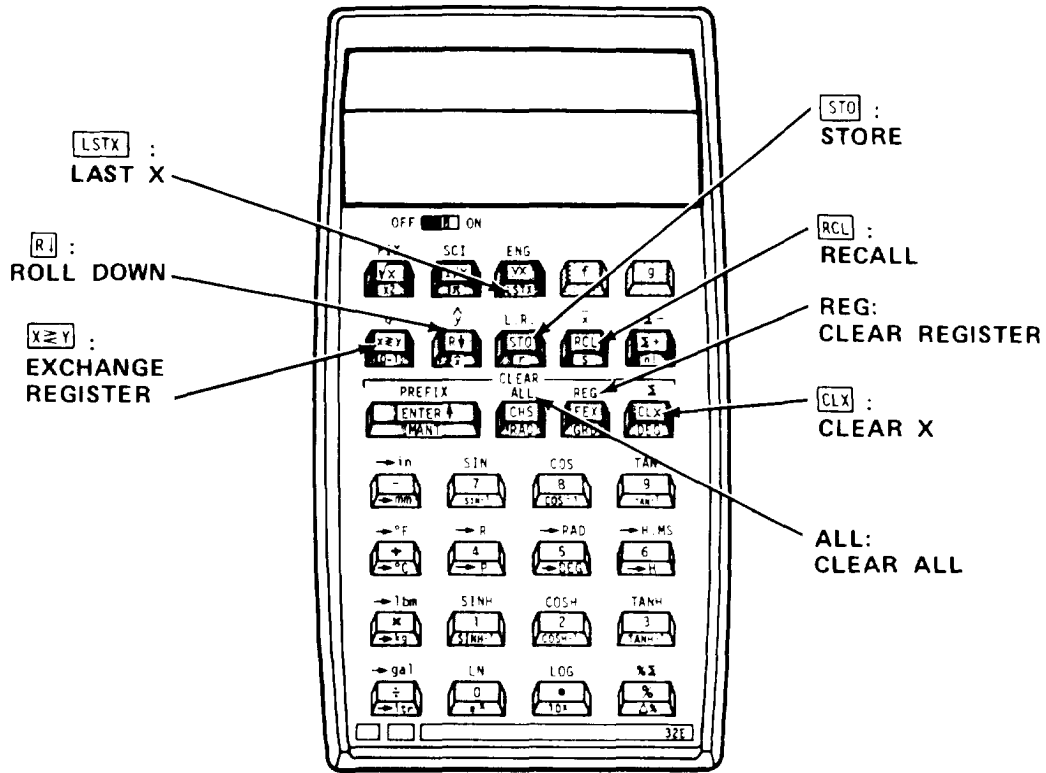

Number Manipulation

$X \leftrightarrow Y$	Exchange Register	Interchanges contents of X and Y-registers.
R↓	Roll Down	Rolls down contents of automatic memory stack for viewing in X-register without loss of data. When pressed, contents of X-register is shifted to T-register, T-register shifts to Z-register, Z-register shifts to Y-register, and Y-register advances to X-register for viewing.
CLX	CLEAR X	Clears contents of displayed X-register.

Key	Control or Indicator	Function
ALL	CLEAR ALL	Clears contents of memory stack and all storage registers.
<b>STO</b>	Store	Followed by digit key <b>0</b> through <b>8</b> or by a decimal point and a key <b>0</b> through <b>5</b> , stores displayed number in that specified location. Also used to perform storage register arithmetic.
<b>RCL</b>	Recall	Followed by digit key <b>0</b> thru <b>8</b> or by a decimal point and a digit key <b>0</b> thru <b>5</b> , recalls value from specified storage register into the displayed X-register.
REG	CLEAR Register	Clears contents of storage registers R0 through R8. Contents of registers R.0 thru R.5 are unaffected.
<b>LSTX</b>	LAST X	Recalls number displayed before previous operation back into displayed X-register.

Key

Control or Indicator

Function

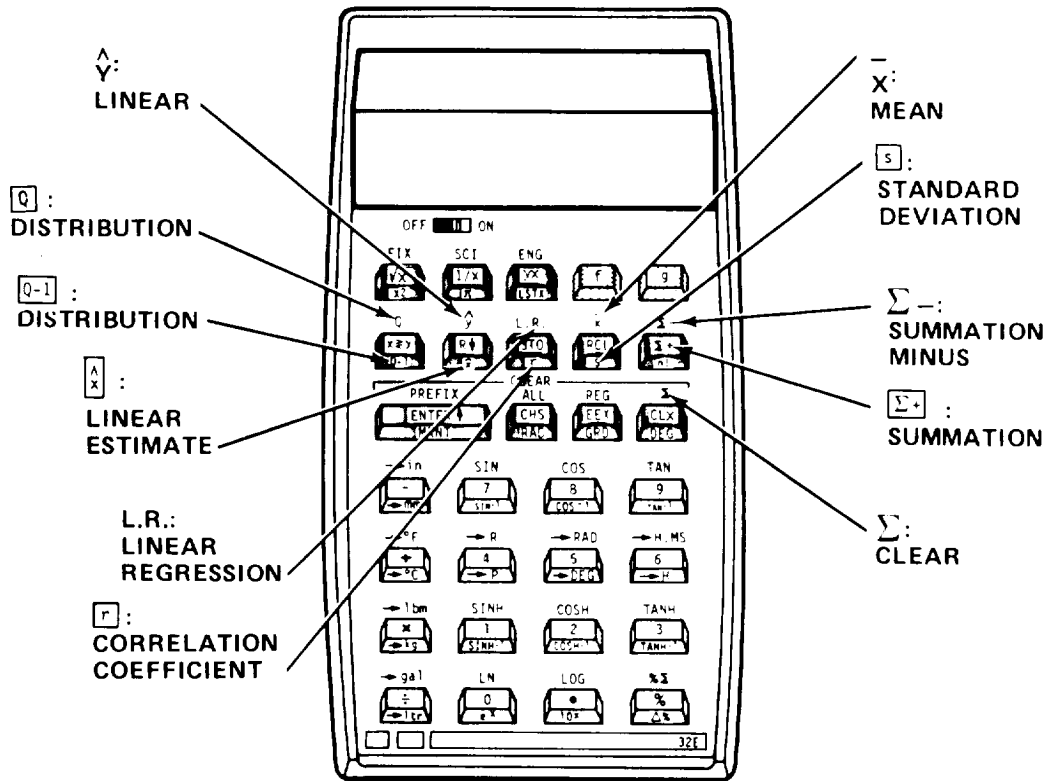

Statistical

Q	Distribution	Computes area under standard normal distribution curve to left of X.
Q-1	Distribution	Computes X, given area under standard normal distribution curve to left of X.
$\hat{Y}$	Linear Estimate	Computes estimated value of Y for a given value of X.
$\hat{X}$	Linear Estimate	Computes estimated value of X for a given value of Y.

Key	Control or Indicator	Function
L.R.	Linear Regression	Computes Y-intercept and slope for linear function approximated by X and Y values accumulated using $\Sigma^+$ . Value of slope is placed in Y-register.
$r$	Correlation Coefficient	Computes goodness of fit between X and Y values accumulated using $\Sigma^+$ and linear function which they approximate.
$\bar{X}$	MEAN	Computes mean (average) of X and Y values accumulated using $\Sigma^+$ .
$S$	Standard Deviation	Computes standard deviations of X and Y values accumulated using $\Sigma^+$ .
$\Sigma^+$	Summation	Accumulates statistical data in storage registers R.0 thru R.5 using numbers in X- and Y-registers.
-	Summation Minus	Subtracts from statistical data in storage registers R.0 thru R.5 using numbers in X- and Y-registers.
	CLEAR	Clears statistical storage registers R.0 thru R.5.

Key	Control or Indicator	Function
-----	----------------------	----------

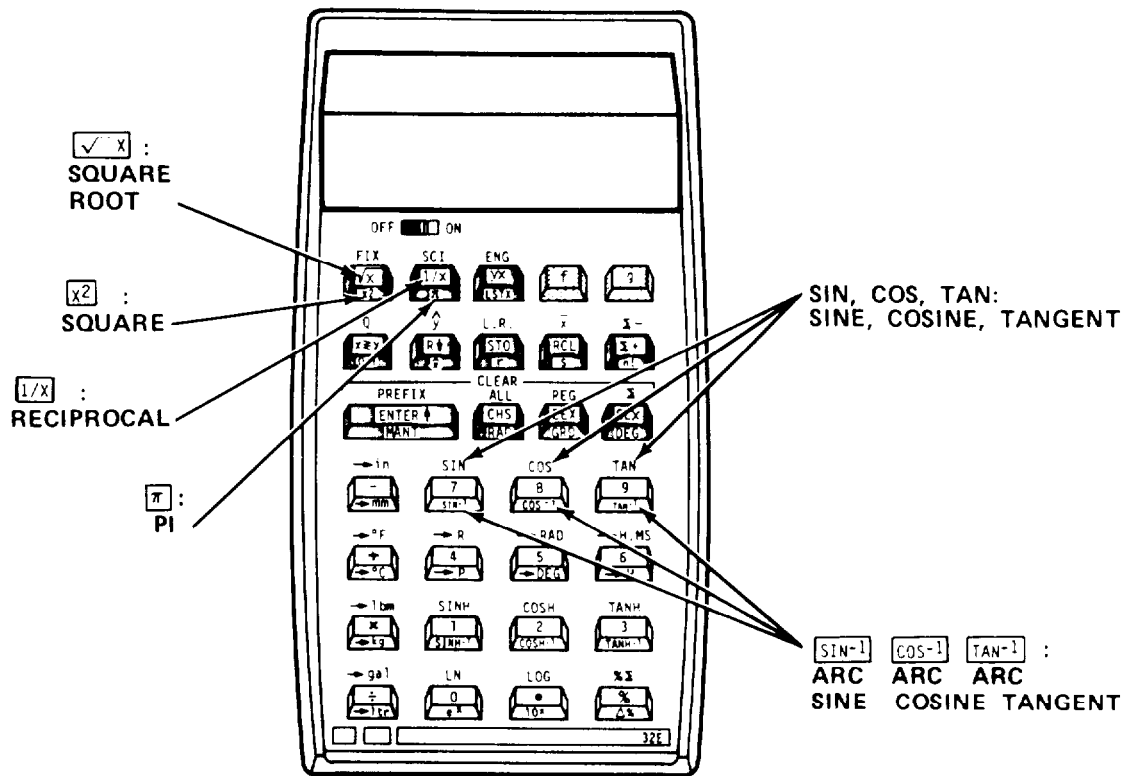

$\sqrt{x}$	Square Root	Computes square root of number in displayed X-register.
$x^2$	Square	Computes square of number in displayed X-register.
$1/x$	Reciprocal	Computes reciprocal of number in displayed X-register.
$\pi$	pi	Places value of pi (3.141592654) into X-register.
SIN, COS, TAN	Sine, Cosine, Tangent	Computes sine, cosine, or tangent of number in displayed X-register.

Key	Control or Indicator	Function
$\boxed{\text{SIN}^{-1}}$ , $\boxed{\text{COS}^{-1}}$ $\boxed{\text{TAN}^{-1}}$	Arc Sine, Arc Cosine, Arc Tangent	Computes arc sine, arc cosine, or arc tangent of number in displayed X-register.

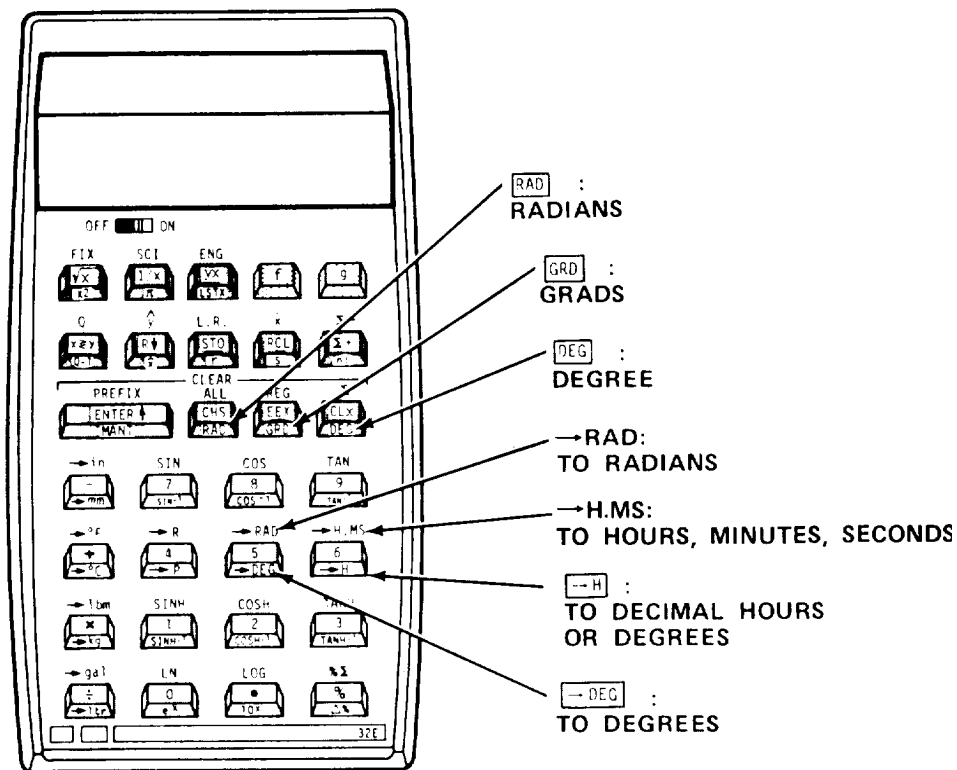

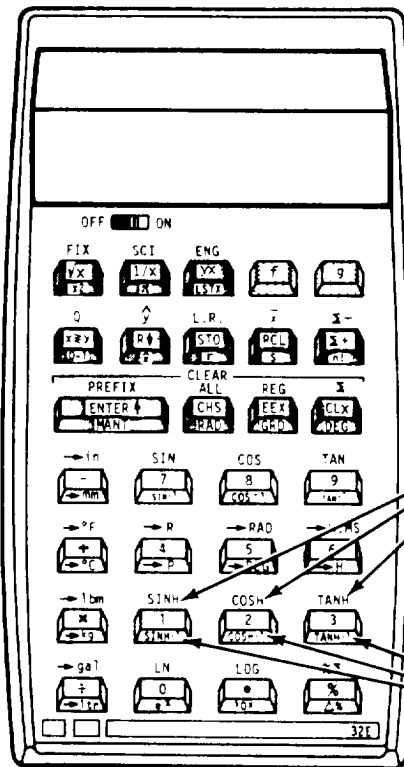

$\boxed{\text{RAD}}$	Radians	Sets radians mode for all trigonometric functions.
$\boxed{\text{GRD}}$	Grads	Sets grads mode for all trigonometric functions.
$\boxed{\text{DEG}}$	Degree	Sets decimal degrees mode for all trigonometric functions.
$\rightarrow \text{RAD}$	To Radians	Converts decimal degrees to radians.
$\rightarrow \text{DEG}$	To Degrees	Converts radians to decimal degrees.

Key	Control or Indicator	Function
→H.MS	To Hours. Minutes Seconds	Converts decimal hours or degrees to hours, minutes, seconds or degrees, minutes, seconds.
⇐H	To Decimal Hours or Degrees	Converts hours, minutes, seconds, or degrees, minutes, seconds to decimal hours or degrees.





---

Key	Control or Indicator	Function
Hyperbolic		
SINH, COSH, TANH	Hyperbolic Sine, Cosine, and Tangent	Computes hyperbolic sine, hyperbolic cosine, or hyperbolic tangent of number in displayed X- register.
 ,  , 	Inverse Hyperbolic Sine, Cosine, Tangent	Computes inverse hyper- bolic sine, inverse hyperbolic cosine, or inverse hyperbolic tangent of number in dis- played X-register.

Key	Control or Indicator	Function
-----	----------------------	----------

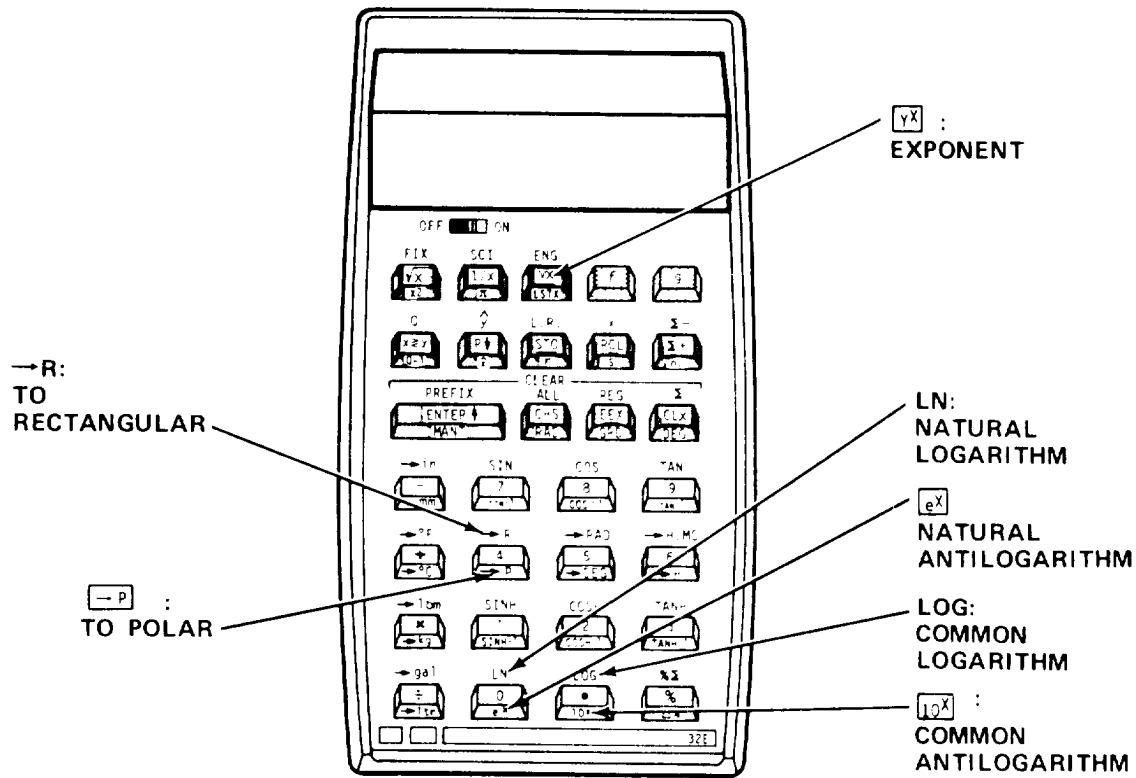

Logarithmic and Exponential

$y^x$	Exponent	Raises number in Y-register to power of number in displayed X-register.
LN	Natural Logarithm	Computes natural logarithm (base e) of number in displayed X-register.
$e^x$	Natural Antilogarithm	Raises e to power of number in displayed X-register.
LOG	Common Logarithm	Computes common logarithm (base 10) of number in displayed X-register.

---

Key	Control or Indicator	Function
$10^X$	Common Antilogarithm	Raises 10 to power of number in displayed X-register.
$\rightarrow P$	To Polar	Converts rectangular (X,Y) or coordinates in X- and Y - registers into polar (R, $\theta$ ) coordinates. Angle $\theta$ stored in Y-register.
$\rightarrow R$	To Rectangular	Converts polar (R, $\theta$ ) coordinates in X- and Y-registers into rectangular (X, Y) coordinates.

---

Key

Control or Indicator

Function

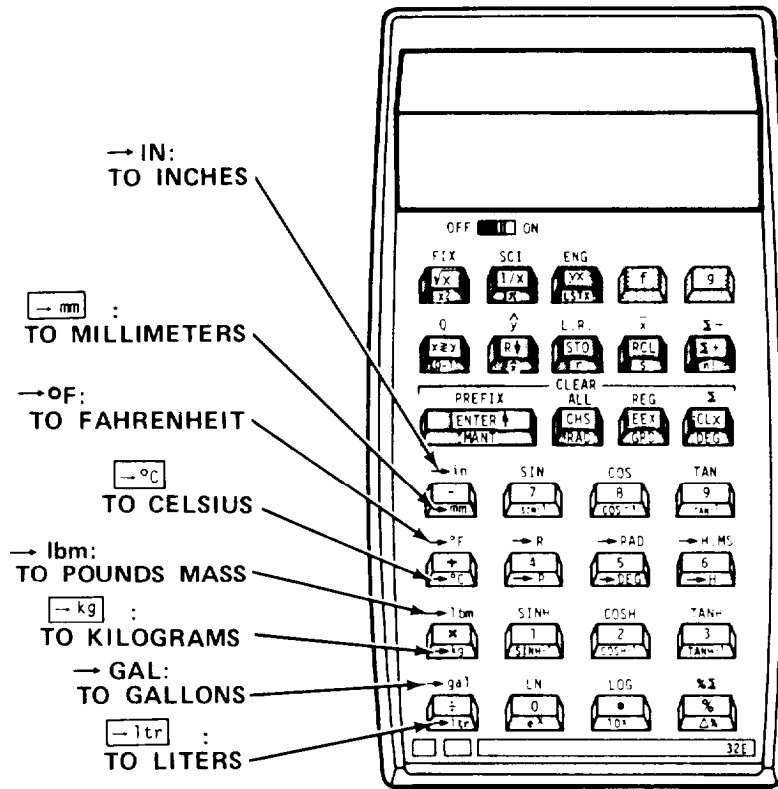

Metric Conversions

→ in	To Inches	Converts millimeters to inches.
[- mm]	To Millimeters	Converts inches to millimeters.
→ °F	To Fahrenheit	Converts degrees Celsius to degrees Fahrenheit.
[- °C]	To Celsius	Converts degrees Fahrenheit to degrees Celsius.
→ lbm	To Pounds Mass	Converts kilograms to pounds mass.
[- kg]	To Kilograms	Converts pounds mass to kilograms.

Key	Control or Indicator	Function
-----	----------------------	----------

To Gallons

Converts liters to gallons (U.S.).

To Liters

Converts gallons (U.S.) to liters.

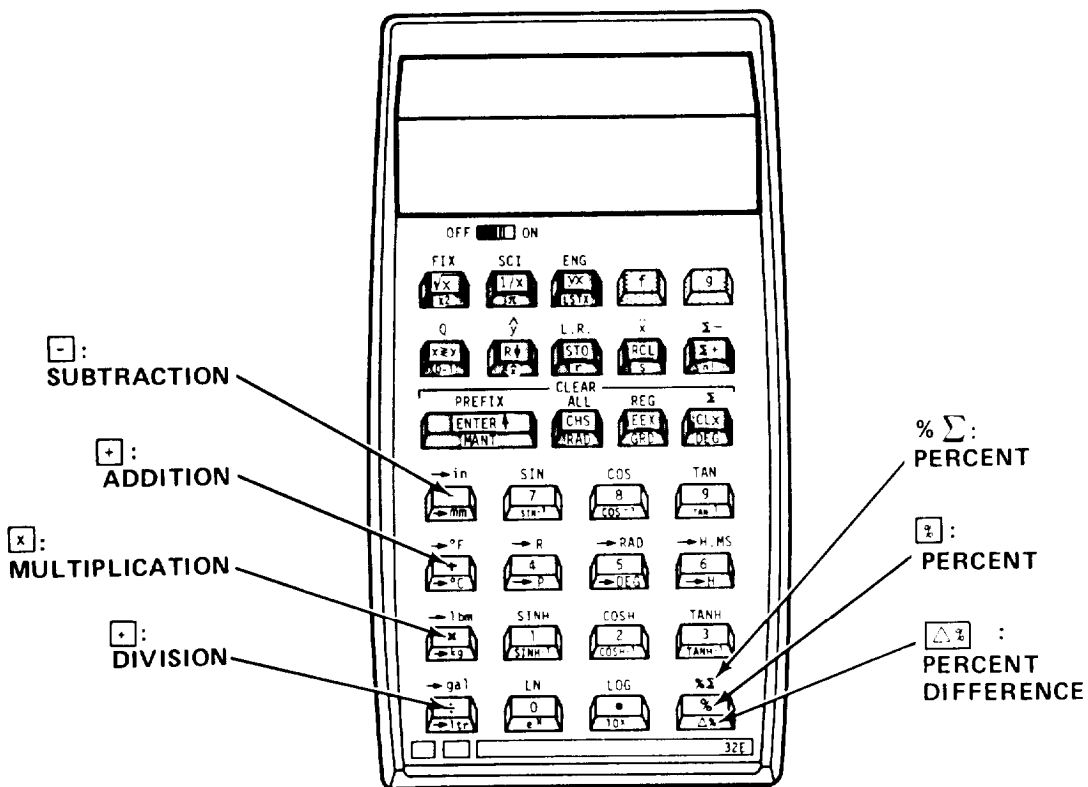

Percentage

$\%$	Percent	Computes X-percent of Y.
$\Delta \%$	Percent Difference	Computes percent difference between number in Y-register and number in X-register.
$\% \Sigma$	Percent	Computes percent that X is of the number ( $\Sigma X$ ) in storage register R <sub>n</sub> .

Arithmetic Functions

$+$	Addition	Arithmetic functions
$-$	Subtraction	
$\times$	Multiplication	
$\div$	Division	

### 3-5. OPERATOR PREVENTIVE MAINTENANCE CHECKS AND SERVICES.

- a. Before You Operate. Always keep in mind the WARNINGS and CAUTIONS. Perform your before (B) PMCS.
- b. While You Operate. Always keep in mind the WARNINGS and CAUTIONS. Perform your during (D) PMCS.
- c. After You Operate. Be sure to perform your after (A) PMCS.
- d. If Your Equipment Fails to Operate. Troubleshoot with proper equipment. Report any deficiencies using the proper forms. See DA Pam 738-750.

#### 3-5.1 PMCS Procedures.

- a. PMCS are designed to keep the equipment in good working condition by performing periodic service tasks.
- b. Service intervals provide you, the operator, with time schedules that determine when to perform specified service tasks.
- c. The "Equipment is Not Ready/Available If" column is used for identification of conditions that make the equipment not ready/available for readiness reporting purposes or denies use of the equipment until corrective maintenance is performed.
- d. If your equipment fails to operate after PMCS is performed, immediately report this condition to your supervisor.
- e. Perform weekly as well as before operation if you are the assigned operator and have not operated the item since the last weekly or if you are operating the item for the first time.
- f. Item number column. Item numbers are assigned in chronological ascending sequence regardless of interval designation. These numbers are used for your "TM Number" column on DA Form 2404, Equipment Inspection and Maintenance Worksheet in recording results of PMCS.
- g. Interval columns. This column determines the time period designated to perform your PMCS.
- h. Item to be inspected and procedures column. This column lists functional groups and their respective assemblies and subassemblies as shown in the Maintenance Allocation Chart (Appendix B). The appropriate check or service procedure follows the specific item to be inspected.
- i. Equipment is not ready/available if: column. This column indicates the reason or cause why your equipment is not ready/available to perform its primary mission.

j. List of tools and materials required for PMCS is as follows.

<u>Item</u>	<u>Quantity</u>
Cheesecloth (Item 5, Appendix E)	ar

Table 3-1. OPERATOR PREVENTIVE MAINTENANCE CHECKS AND SERVICES

NOTE

If the equipment must be kept in continuous operation, check and service only those items that can be checked and serviced without disturbing operation. Make the complete checks and services when the equipment can be shut down.

B - Before  
D - During  
A - After

W - Weekly  
M - Monthly  
Q - Quarterly

AN - Annually  
S - Semiannually  
BI - Biennially

(Number) - Hundreds of Hours

ITEM NO.	INTERVAL	ITEM TO BE INSPECTED  PROCEDURE	For Readiness Reporting, Equipment is Not Ready/ Available If:
1	B	<p><b>POCKET CALCULATOR</b></p> <p>Inspect.</p>  <p>1. Check keyboard, display, and casing for cracks or breaks. Replace calculator if casing or display is cracked or broken.</p>	<p>Calculator keyboard, display, or casing is damaged.</p>



Table 3-1. OPERATOR PREVENTIVE MAINTENANCE CHECKS AND SERVICES - Cont

		B - Before D - During A - After	W - Weekly M - Monthly Q . Quarterly	AN - Annually S - Semiannually BI - Biennially	(Numbered - Hundreds of Hours)	
ITEM NO.	INTERVAL	ITEM TO BE INSPECTED			PROCEDURE	For Readiness Reporting, Equipment is Not Ready/ Available If:
1	B	<b>POCKET CALCULATOR - Cont</b>				
		<u>Inspect - Cont</u>				
		2. Connect ac adapter/recharger to calculator and plug in. Turn calculator on. Press <b>STO</b> and <b>ENTER</b> . Display should indicate -8, 8, 8, 8, 8, 8, 8, 8, 8, 8, 8.				Display does not show - 8, 8,8, 8, 8, 8,8, 8, 8, 8.
		3. With battery pack in calculator, check operation to be sure calculator turns on. Remove battery pack and check for clean contacts. Wipe clean. Reinstall battery pack.				Battery pack is defective.
		4. Check power cord for kinks, frays or burns.				Power cord is damaged.

**3-6. OPERATION UNDER USUAL CONDITIONS.**

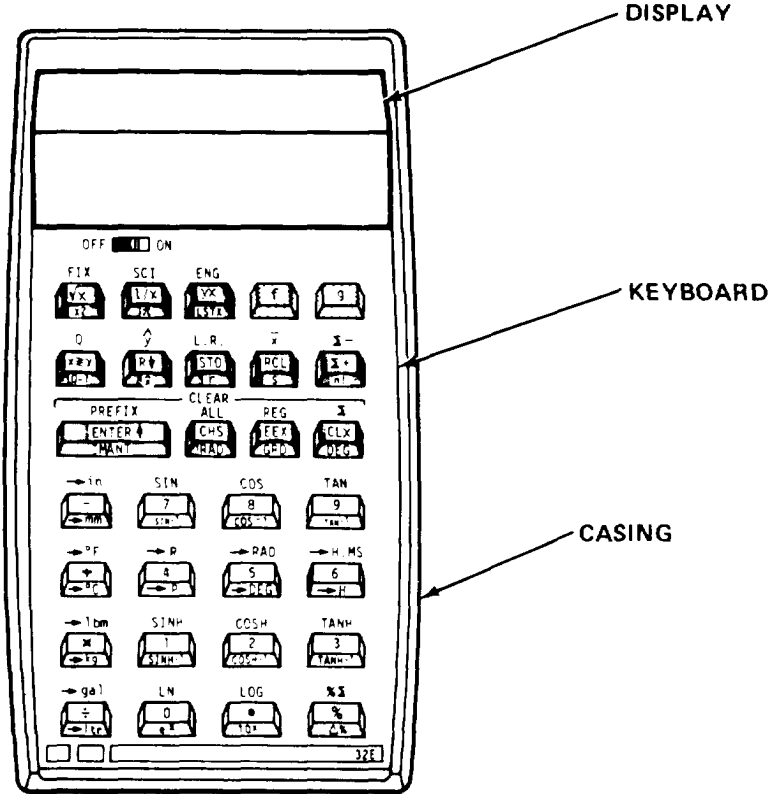
3-6.1 Operating Procedure.

- a. Selecting a function.

**NOTE**

Most keys on the keyboard perform three functions. One function is indicated by symbol on top of key, second is above key, and third is on slanted face of key.

(1) To select a function printed on the key, press the key.

(2) To select a function printed above the key, press key **f** , then function key.

Example: To use **LOG** in calculation, enter number, **f** then LOG.

(3) To select a function printed on slanted face of key, press **g** then function key.

Example: To use **x<sup>2</sup>** in calculations, enter number, **g** then **x<sup>2</sup>** .

b. Keying in numbers.

(1) Press keys corresponding to digits and decimal point in the order that they appear, reading from left to right.

(2) If needed, press  $\boxed{\text{CHS}}$  to make number negative.

c. One-number functions.

(1) Key in number on which operation is to be performed.

(2) Select desired function. Press key.

Example: To calculate square root of 5, press  $\boxed{5}$  and  $\boxed{\sqrt{x}}$ .

Answer is 2.2361.

d. Two-number functions.

(1) Key in first number.

(2) Press  $\boxed{\text{ENTER}}$  to separate first number from second number.

(3) Key in second number.

(4) Select desired function. Press key.

Example: To calculate 5 percent of 35, press  $\boxed{5}$ ,  $\boxed{\text{ENTER}}$ ,  $\boxed{5}$  and  $\boxed{\%}$ .

Answer is 1.75.

e. Exponent key  $\boxed{y^x}$ .

**NOTE**

Exponent key is two-number function.

(1) Key in number for Y. Press  $\boxed{\text{CHS}}$  if it is negative.

(2) Press  $\boxed{\text{ENTER}}$  to send number to Y register in automatic memory stack.

(3) Key in number for X (exponent for Y).

(4) Press  $\boxed{y^x}$  key.

Example: To calculate  $5^3$ , press  $\boxed{\text{ENTER}}$ ,  $\boxed{3}$ , and  $\boxed{y^x}$ .

Answer is 125.

f. Chain calculations.

**NOTE**

Calculator uses reverse polar notation (RPN) logic for chain calculations.

(1) If equation has parenthetical expressions, key in numbers and perform function in first parenthesis. Key in first number, press **ENTER**, key in second number, and press function key for that operation.

(2) Key in numbers and perform function in second parenthesis. Key in first number, press **ENTER**, key in second number, then press function key for that operation.

(3) Press function key for operation indicated between parentheses.

Example: To calculate  $(3 \times 4) \times (5 + 6)$ , press

**3**, **ENTER**, **4**, and **x**  
**5**, **ENTER**, **6**, and **+**  
**x**; answer is 132.

g. Operations with powers of 10.

(1) Key in number being multiplied by power of 10. Press **CHS** if number is negative.

(2) Press **EEX**.

(3) Key in exponent (power) of 10. Press **CHS** if exponent is negative.

(4) Press **ENTER**, and key in exponent.

(5) Press **x**.

Example: To multiply  $15.6 \times 10^{12}$  by 25 press

**1**, **5**, **.**, **6**, **EEX**, and **12**  
**ENTER**, **25**, and **x**; answer is  $3.9000 \times 10^{14}$ .

h. Storage (memory) register arithmetic.

**NOTE**

This procedure performs two-number arithmetic functions on number stored in storage register. The displayed X-register is the second number.

(1) Press **STO**.

(2) Press appropriate function key **+**, **-**, **x**, or **÷**

(3) Press **0** through **8** or, **.** **0** through **.** **5**, indicating on which register function will be performed.

**Example:** Pressing  $\boxed{\text{STO}}$  ,  $\boxed{\times}$  , and  $\boxed{1}$  multiplies value of (displayed) X-register by contents of storage (memory) register 1. The answer is placed into storage (memory) register 1.

**NOTE**

Value of X-register will not be changed.

i. Clearing storage (memory) register.

(1) To clear single storage (memory) register, press  $\boxed{0}$  ,  $\boxed{\text{STO}}$  , and location of register to be cleared.

**Example:** To clear register 2, press  $\boxed{0}$  ,  $\boxed{\text{STO}}$  , and  $\boxed{2}$  .

(2) To clear registers 0 through 8, press  $\boxed{f}$  and **REG**. To clear registers 0 through 5, press  $\boxed{f}$  and  $\boxed{\cdot}$   $\boxed{\cdot}$  to clear all registers (including the automatic memory stack) press  $\boxed{f}$  and **ALL**.

j. Trigonometric functions.

(1) Enter or calculate value of X, number on which trigonometric function is to be performed.

(2) Press  $\boxed{g}$  key.

(3) Press  $\boxed{\text{DEG}}$  ,  $\boxed{\text{RAD}}$  , or  $\boxed{\text{GRD}}$  to select measurement for answer (degrees, radians, or grads).

(4) Press  $\boxed{f}$  key.

(5) Press needed function (SIN, COS, TAN) key.

**Example:** To calculate sine 35 , press  $\boxed{3}$  ,  $\boxed{5}$  ,  $\boxed{g}$  ,  $\boxed{\text{DEG}}$  ,  $\boxed{f}$  , and **SIN** . Answer is 0.5736.

k. Polar/rectangular coordinate conversion.

(1) Convert from rectangular (X, Y) to polar coordinates.

**NOTE**

Value for Y is always keyed in first.

(a) Key in value of Y.

(b) Press  $\boxed{\text{ENTER}}$  .

(c) Key in value of X.

(d) Press then key in  $\boxed{\text{DEG}}$  ,  $\boxed{\text{RAD}}$  or  $\boxed{\text{GRD}}$  to select measurement for answer (degrees, radians, or grads).

(e) Press  $\boxed{9}$  and  $\boxed{-P}$  to get R (magnitude). Press  $\boxed{X\leftrightarrow Y}$  to get angle in radians.

Example: To convert rectangular coordinates 4, 3 to polar with angle in radians, press

$\boxed{3}$  ,  $\boxed{\text{ENTER}}$  , and  $\boxed{4}$   
 $\boxed{9}$  and  $\boxed{\text{RAD}}$   
 $\boxed{9}$  and  $\boxed{-P}$  ; answer is 5.  
 $\boxed{X\leftrightarrow Y}$  ; answer is .64.

(2) Convert from polar to rectangular coordinates.

(a) Key in angle in radians.

(b) Press  $\boxed{\text{ENTER}}$  .

(c) Key in value of R (magnitude).

(d) Press  $\boxed{9}$  then key in  $\boxed{\text{DEG}}$  ,  $\boxed{\text{RAD}}$  , or  $\boxed{\text{GRD}}$  to select measurement of angle (degrees, radians, or grads).

(e) Press  $\boxed{9}$  , R to get X. Press  $\boxed{X\leftrightarrow Y}$  to get Y.

Example: To convert polar coordinates 5 and .64 to rectangular, press

$\boxed{.}$  ,  $\boxed{6}$  ,  $\boxed{4}$  ,  $\boxed{\text{ENTER}}$  , and  $\boxed{5}$   
 $\boxed{9}$  and  $\boxed{\text{RAD}}$   
 $\boxed{9}$  and  $\boxed{-R}$  : answer is 4.01.  
 $\boxed{X\leftrightarrow Y}$  : answer is 2.986.

## 1. Statistical functions.

### (1) Accumulations.

(a) Pressing  $\boxed{\Sigma+}$  key computes sums and products of the values in the X- and Y-registers. Results are automatically accumulated in storage registers R through R. Before starting to calculate accumulations with a new set of x and y values, clear registers by pressing  $\boxed{f}$  REG.

Key y value into X-register.

Press  $\boxed{\text{ENTER}}$  to raise y value into Y-register.

Key x value into X-register.

Press  $\boxed{\Sigma+}$  .

b. If statistical problem involves only one variable (x), clear storage registers R.0 through R.5 and Y-register. Press  $\boxed{f}$ ,  $\Sigma$ , and  $\boxed{\text{ENTER}}$ .

Key number into X-register.

Press  $\boxed{\Sigma^+}$ .

**NOTE**

Unlike storage register arithmetic, the accumulation operation allows overflows (i.e., number whose magnitudes are greater than  $9.99999999 \times 10$ ) in storage registers R.0 through R.5 without indicating Error 1 in the display.

c. To use any of the accumulations, recall contents of desired storage register into displayed X-register by pressing  $\boxed{\text{RCL}}$   $\boxed{\cdot}$  followed by the number of the register. If this is done immediately after pressing  $\boxed{\Sigma^+}$  or  $\Sigma^-$ , the accumulation reads written over the number of data pair entries (n) in the display. To use both  $\Sigma X$  and  $\Sigma Y$ , press  $\boxed{\text{RCL}}$   $\boxed{\Sigma^+}$ . This simultaneously copies  $\Sigma X$  from R.1 into displayed X-register and copies  $\Sigma Y$  from R.3 into Y-register. If this is done immediately after pressing  $\Sigma^-$ ,  $\boxed{\text{CLX}}$ , or  $\boxed{\text{ENTER}}$ , the number in the Y-register is first lifted into the Z-register. Otherwise, the numbers in the X- and Y-registers are first lifted into Z- and T- registers, respectively.

Example: To find  $\Sigma x$ ,  $\Sigma x^2$ ,  $\Sigma y$ ,  $\Sigma y^2$ , and  $\Sigma xy$  for the paired values of x and y listed below, press

```

y 7 5 9
-----
x 5 3 8
    
```

<u>Keystrokes</u>	<u>Display</u>	
$\boxed{f}$ CLEAR $\Sigma$	0.0000	Clear statistical storage registers. (Display shown assumes no results remain from previous calculations.)
$\boxed{7}$ $\boxed{\text{ENTER}}$	7.0000	
$\boxed{5}$ $\boxed{\Sigma^+}$	1.0000	First pair is accumulated: n=1
$\boxed{5}$ $\boxed{\text{ENTER}}$	5.0000	
$\boxed{3}$ $\boxed{\Sigma^+}$	2.0000	Second pair is accumulated: n=2
$\boxed{9}$ $\boxed{\text{ENTER}}$	9.0000	
$\boxed{8}$ $\boxed{\Sigma^+}$	3.0000	Third pair is accumulated: n=3

<u>Keystrokes</u>	<u>Display</u>	
RCL . 1	16.0000	Sum of x values from register R.1
RCL . 2	98.0000	Sum of squares of x values from register R.2
RCL . 3	21.0000	Sum of y values from register R.3
RCL . 4	155.0000	Sum of squares of y values from register R.4
RCL . 5	122.0000	Sum of products of x and y values from register R.5
RCL . 0	3.0000	Number of entries (n=3) from register R.0

(2) Deleting and correcting data.

(a) If an incorrect value is keyed in and  $\Sigma^+$  has not yet been pressed, press  $\text{CLX}$  and key in correct value.

(b) To change one of the values, or if after pressing  $\Sigma^+$  one of the values was erroneous, correct the accumulations by using  $\Sigma^-$  (summation minus) key as follows:

Key incorrect data pair into X- and Y-registers.  
 $\text{LSTX}$  can be used to return a single incorrect data value to displayed X-register.

Press  $\text{f} \Sigma^-$  to delete incorrect data.

Key in correct values for x and y. If one value of an (x, y) data pair is incorrect, both values must be deleted and reentered.

Press  $\Sigma^+$ .

Example: If last data pair (8, 9) in previous example should have been (8, 6), correct the accumulation as follows, press

<u>Keystrokes</u>	<u>Display</u>	
9 ENTER	9.0000	Incorrect y value is entered again.
8	8.	Correct x value is entered again.
f $\Sigma^-$	2.0000	Number of entries (n) is now two.

<u>Keystrokes</u>	<u>Display</u>	
<b>6</b> <b>ENTER</b>	6.0000	Correct y value is entered.
<b>8</b>	8.	x value is entered again.
<b>Σ+</b>	3.0000	Number of entries is again three.

(3) Mean. Pressing **Σ** computes the arithmetic mean (average) of x and y values accumulated in registers R.1 and R.3 respectively.

Pressing **Σ** **Σ** causes the following operations to be performed.

The contents of the stack registers are lifted just as they are when pressing **RCL** .

The mean of the x values ( $\bar{x}$ ) is calculated using data accumulated in registers **R.1** ( $\sum x$ ) and **R.0** (n). The resulting value for x appears in displayed X-register.

The mean of y values ( $\bar{y}$ ) is calculated using data accumulated in registers **R.3** ( $\sum y$ ) and **R.0** (n).

The resulting value for y is available in Y-register of stack.

Example: Below is a chart of daily high and low temperatures for a winter week. To find average high and low temperatures for week selected, press

	Sun	Mon	Tues	Wed	Thurs	Fri	Sat
High	6	11	14	12	5	-2	-9
Low	-22	-17	-15	-9	-24	-29	-35

<u>Keystrokes</u>	<u>Display</u>	
	0.0000	Statistical registers cleared. (Display shown assumes no results remain from previous calculations.)
<b>6</b> <b>ENTER</b>	22	22.
<b>CHS</b> <b>Σ+</b>	1.0000	Number of data pairs (n) is now 1.
14 <b>ENTER</b> 15	17.	
<b>CHS</b> <b>Σ+</b>	2.0000	Number of data pairs (n) is now 2.
11 <b>ENTER</b> 17	15.	



<u>Keystrokes</u>	<u>Display</u>	
$\boxed{\text{CHS}}$ $\boxed{\Sigma^+}$	3.0000	
12 $\boxed{\text{ENTER}}$ $\boxed{9}$	9.	
$\boxed{\text{CHS}}$ $\boxed{\Sigma^+}$	4.0000	
$\boxed{5}$ $\boxed{\text{ENTER}}$ 24	24.	
$\boxed{\text{CHS}}$ $\boxed{\Sigma^+}$	5.0000	
$\boxed{2}$ $\boxed{\text{CHS}}$ $\boxed{\text{ENTER}}$	-2.0000	
29 $\boxed{\text{CHS}}$ $\boxed{\Sigma^+}$	6.0000	
$\boxed{9}$ $\boxed{\text{CHS}}$ $\boxed{\text{ENTER}}$	-9.0000	
35 $\boxed{\text{CHS}}$ $\boxed{\Sigma^+}$	7.0000	Number of data pairs (n) is now 7.
$\boxed{f}$ $\boxed{\overset{A}{X}}$	-21.5714	Average low temperature.
$\boxed{X \geq Y}$	5.2857	Average high temperature.

(4) Standard deviation.

(a) Pressing  $\boxed{S}$  computes the standard deviation (a measure of dispersion around the mean) of accumulated data.

(b) When  $\boxed{9}$   $\boxed{S}$  is pressed:

The contents of stack registers are lifted just as they are when pressing  $\boxed{\text{RCL}}$   $\boxed{\Sigma^+}$ .

The standard deviation of x values ( $s_x$ ) is calculated using data accumulated in registers R.2 (2), R.1 ( $\Sigma$ ), and R.0 (n). The result appears in displayed X-register.

The standard deviation of y values (s) is calculated using data accumulated in registers R.4 (y2), R.3 (y), and R.0 (n). The result appears in Y-register.

Example: To determine the standard deviation of the following test scores: 79, 94, 68, 86, 82, 78, 83, and 89, press

<u>Keystrokes</u>	<u>Display</u>	
$\boxed{f}$ CLEAR ALL	0.0000	Clear statistical registers and Y-register for new, one-variable problem.

Keystrokes	Display	
79 +	1.0000	First score is entered. Since this problem involves only one variable, y-value does not have to be entered into Y-register using the <b>ENTER</b> key.
94 $\Sigma^+$	2.0000	Display shows number of scores entered so far.
68 $\Sigma^+$	3.0000	
86 $\Sigma^+$	4.0000	
82 $\Sigma^+$	5.0000	
78 $\Sigma^+$	6.0000	
83 $\Sigma^+$	7.0000	
89 $\Sigma^+$	8.0000	Last score in sample.
$\square$ $\square$	7.8365	Standard deviation of test scores.

(5) Linear regression. Linear regression is a statistical method for finding a straight line that best fits a set of data points, thus providing a relationship between two variables.

(a) To use the linear regression function, first key in a series of data points using the  $\Sigma^+$  key. Then press  $\square$  L.R.

(b) When  $\square$  L.R. is pressed:

The contents of the stack registers are lifted just as they are when you press  $\square$   $\Sigma^+$ .

The slope (A) of the least squares line of the data is available in the Y-register of the stack.

The y-intercept (B) of the least squares line of the data appears in the displayed X-register of the stack.

(c) To use value for A or to bring it into displayed X-register, simply shift stack contents with the  $\square$  key.

**Example:** An oil company wishes to know the slope and y-intercept of a least squares line for the consumption of motor fuel in the United States against time since 1945. It knows the data given in the table.

Motor Fuel Demand (Millions of Barrels)	696	994	1330	1512	1750	2162	2243	2382	2484
--	-----	-----	------	------	------	------	------	------	------

Year	1945	1950	1955	1960	1965	1970	1971	1972	1973
------	------	------	------	------	------	------	------	------	------

Solution: Key the data into the calculator using the  $\Sigma^+$  key, then press  $f$  L.R.

<u>Keystrokes</u>	<u>Display</u>
$f$ CLEAR $\Sigma^+$	0.0000
696 $\text{ENTER}$	696.0000
1945 $\Sigma^+$	1.0000
994 $\text{ENTER}$	994.0000
1950 $\Sigma^+$	2.0000
1330 $\text{ENTER}$	1,330.0000
1955 $\Sigma^+$	3.0000
1512 $\text{ENTER}$	1,512.0000
1960 $\Sigma^+$	4.0000
1750 $\text{ENTER}$	1,750.0000
1965 $\Sigma^+$	5.0000
2162 $\text{ENTER}$	2,162.0000
1970 $\Sigma^+$	6.0000
2243 $\text{ENTER}$	2,243.0000
1971 $\Sigma^+$	7.0000
2382 $\text{ENTER}$	2,382.0000
1972 $\Sigma^+$	8.0000
2484 $\text{ENTER}$	2,484.0000
1973 $\Sigma^+$	9.0000

Clear statistical storage registers. (Display shown assumes no results remain from previous calculations).

All data pairs have been keyed in.

<u>Keystrokes</u>	<u>Display</u>	
$\boxed{f}$ L.R.	-118,290.6295	The y-intercept of the line.
$\boxed{x \approx y}$	61.1612	Slope of the line.

(6) Linear estimation. With data accumulated in registers R.0 through R.5 a predicted value for y (denoted  $\hat{y}$ ) can be calculated by keying in a new value for x and pressing  $\boxed{f} \hat{y}$ . A predicted value for x (denoted  $\hat{x}$ ) can be calculated by keying in a new value for y and pressing  $\boxed{g} \hat{x}$ .

Example: With data intact from previous example in registers R.0 through R.5 to predict demand for motor fuel for the years 1980 and 2000, key in new x values and press  $\boxed{f} \hat{y}$ . To determine the year that the demand for motor fuel is expected to pass 3,500 million barrels, key in 3,500 (new value for y) and press  $\boxed{g} \hat{x}$ .

<u>Keystroke</u>	<u>Display</u>	
1980 $\boxed{f} \hat{y}$	2,808.6264	Predicted demand in millions of barrels for the year 1980.
2000 $\boxed{f} \hat{y}$	4,031.8512	Predicted demand in millions of barrels for the year 2000.
35 $\boxed{g} \hat{x}$	1,991.3041	The demand is expected to pass 3,500 million barrels during 1992.

(7) Correlation coefficient. Both linear regression and linear estimation presume that the relationship between x and y data values can be approximated, to some degree, by a linear function (a straight line).  $\boxed{r}$  (correlation coefficient) can be used to determine how closely the data "fits" a straight line. The correlation coefficient can range from  $r = + 1$  to  $r = - 1$ . At  $r = + 1$ , data falls exactly onto a straight line with positive slope. While at  $r = -1$ , data falls exactly onto a straight line with negative slope. At  $r = 0$ , data cannot be approximated by a straight line.

Example: To calculate the correlation coefficient for previous example press:

<u>Keystrokes</u>	<u>Display</u>	
$\boxed{g} \boxed{r}$	0.9931	The data very closely approximates a straight line.

**3-7. OPERATION UNDER UNUSUAL CONDITIONS.** This equipment is designed for operation only in a controlled environment.

### Section III OPERATOR MAINTENANCE

**3-8. LUBRICATION INSTRUCTIONS.** This equipment does not require lubrication.

**3-9. TROUBLESHOOTING PROCEDURES.**

a. The table lists the common malfunctions which you may find during the operation or maintenance of the pocket calculator or its components. You should perform the tests/inspections and corrective actions in the order listed.

b. This manual cannot list all malfunctions that may occur, nor all tests and corrective actions. If a malfunction is not listed or is not corrected by listed corrective actions, notify your supervisor.

**Table 3-2. TROUBLESHOOTING**

MALFUNCTION	TEST OR INSPECTION	CORRECTIVE ACTION
1. CALCULATOR DISPLAY IS BLANK.	<p>Step 1. Plug in ac adapter/recharger. Turn calculator on.</p> <p>(a) If display of zeros comes on, proceed to step 2.</p> <p>(b) If display is blank, replace adapter/recharger.</p> <p>(c) If problem remains, replace calculator.</p> <p>Step 2. Check for raised decimal point at far left corner of display. Indicates low power condition.</p> <p>(a) If indicator is on, proceed to step 3.</p> <p>(b) If indicator is off, recharge battery pack.</p> <p>Step 3. Check to see if contacts are dirty.</p> <p>(a) Clean contacts on inside of calculator and battery pack with cotton swab (Item 6, Appendix E) moistened with alcohol (Item 3, Appendix E).</p> <p>(b) Replace battery pack. Open battery pack door. Remove defective battery pack. Install new battery pack. Reinstall battery pack door</p>	

Table 3-2. TROUBLESHOOTING - Cont

---

MALFUNCTION
TEST OR INSPECTION
CORRECTIVE ACTION

---

2. CALCULATIONS OR DISPLAY ERRATIC.

Step 1. Check for raised decimal point at far left corner of display. Indicates low power condition.

- (a) Recharge battery pack.
- (b) Replace battery pack.
- (c) Replace calculator.

Step 2. Press STO and ENTER to see if display shows -8,8,8,8,8,8,8,8, not ERROR 9.

If ERROR 9 is displayed, replace calculator.

**NOTE**

For error conditions refer to operator's instructions for the HP-32E provided with equipment.

**3-10. MAINTENANCE PROCEDURES.** There are no operator maintenance procedures assigned for this equipment.

**Section IV ORGANIZATIONAL MAINTENANCE**

**3-11. LUBRICATION INSTRUCTIONS.** This equipment does not require lubrication.

**3-12. REPAIR PARTS; SPECIAL TOOLS; TEST, MEASUREMENT, AND DIAGNOSTIC EQUIPMENT (TMDE); AND SUPPORT EQUIPMENT.** These items are not required at the organizational level of maintenance.

**3-13. SERVICE UPON RECEIPT.****3-13.1 Checking Unpacked Equipment.**

a. Inspect the equipment for damage incurred during shipment. If equipment has been damaged, report the damage on DD Form 6, Packing Improvement Report.

b. Check the equipment against the packing list to see if the shipment is complete. Report all discrepancies in accordance with the instructions of DA Pam 738-750.

c. Check to see whether the equipment has been modified.

**3-14. ORGANIZATIONAL PREVENTIVE MAINTENANCE CHECKS AND SERVICES.** There are no organizational PMCS procedures assigned for this equipment.

**3-15. ORGANIZATIONAL TROUBLESHOOTING PROCEDURES.** There are no organizational troubleshooting procedures assigned for this equipment.

**3-16. MAINTENANCE PROCEDURES.** There are no organizational maintenance procedures assigned for this equipment.

**3-17. PREPARATION FOR STORAGE OR SHIPMENT.** Contact your battalion for packing and shipping instructions.

**Section V DIRECT/GENERAL SUPPORT MAINTENANCE**

There are no direct/general support maintenance procedures assigned for this equipment.







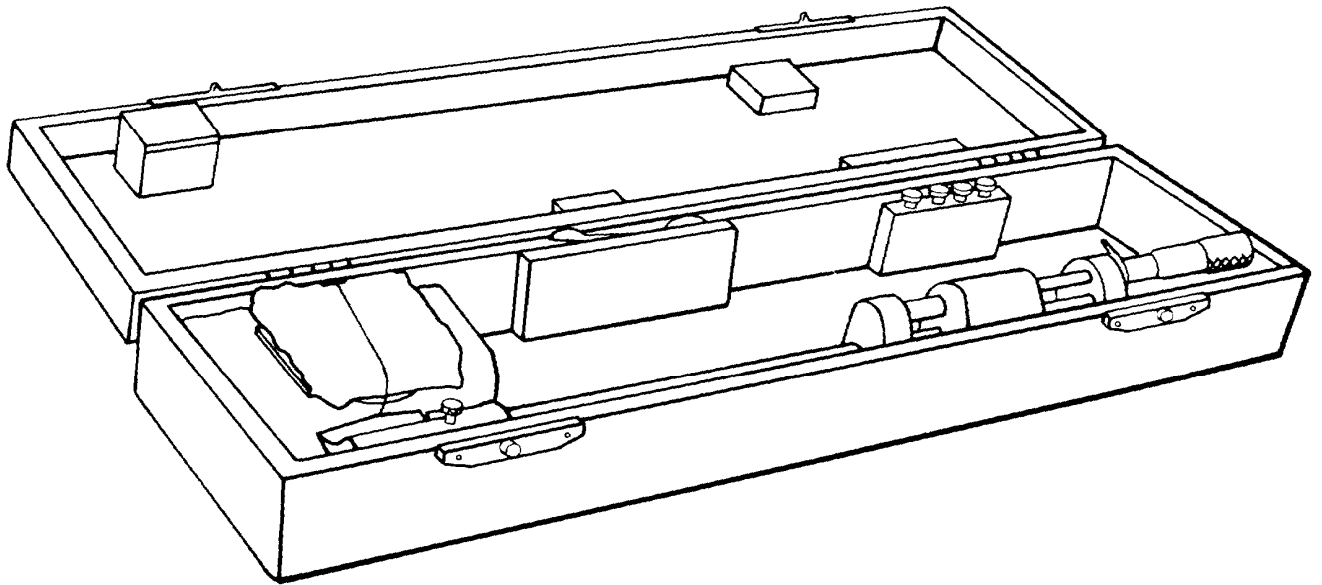

CHAPTER 4

STEREOMETER PARALLAX BAR

Section I INTRODUCTION

4-1. GENERAL INFORMATION.

4-1.1 Scope.

- a. Model Number and Equipment Name. Stereometer parallax bar.
- b. Purpose of Equipment. To determine height differences when viewing stereoscopic photographs.

4-1.2 Glossary.

Absolute Altitude . . . . .	Altitude of aircraft above surface of earth.
Fiducial Mark . . . . .	Marks on edge of photograph to indicate optical center of photograph.
Differential Parallax . . . . .	Small linear displacement between same photographic images on different photographs resulting from height of surface.
Principal Point on Photograph . . . . .	Center of one photograph that can be transferred to adjacent stereophotograph.
Stereo-Pair Photographs . . . . .	Photographs taken at different positions showing same features.

**4-2. EQUIPMENT DESCRIPTION.**

4-2.1 Equipment Characteristics, Capabilities, and Features.

- a. Self-contained with transport case.
- b. Simple computation of values.
- c. No power requirements.

4-2.2 Equipment Data.

Operating Range	8-1/2 to 4-1/2 in. (21.6 to 11.4 cm)
Micrometer Adjustment Range	1 in. (25.4 mm)
Total Adjustment Range	2 in. (5.1 cm)

**4-3. TECHNICAL PRINCIPLES OF OPERATION.** Technical principles of operation are combined with description and use of operator's controls and indicators.

Section II OPERATING INSTRUCTIONS

4-4. DESCRIPTION AND USE OF OPERATOR'S CONTROLS AND INDICATORS.

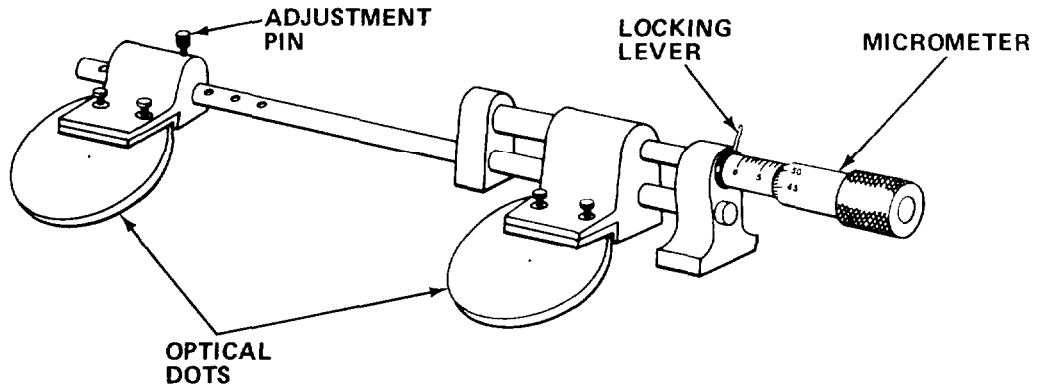

Control or Indicator	Function
Adjustment Pin	Positions left optical dot at one of five positions on arm.
Locking Lever	Locks micrometer.
Micrometer	Rotation of knurled knob precisely moves right optical dot. Amount of movement is read on micrometer in hundredths of millimeters.
Optical Dots	Clear optical glass with center dot.

4-5. OPERATOR PREVENTIVE MAINTENANCE CHECKS AND SERVICES.

- a. Before You Operate. Always keep in mind the WARNINGS and CAUTIONS. Perform your before (B) PMCS.
- b. While You Operate. Always keep in mind the WARNINGS and CAUTIONS. Perform your during (D) PMCS.
- c. After You Operate. Be sure to perform your after (A) PMCS.
- d. If Your Equipment Fails to Operate. Troubleshoot with proper equipment. Report any deficiencies using the proper forms. See DA Pam 738-750.

4-5.1 PMCS Procedures.

- a. PMCS are designed to keep the equipment in good working conditions by performing periodic service tasks.
- b. Service intervals provide you, the operator, with time schedules that determine when to perform specified service tasks.
- c. The "Equipment is Not Ready/Available If" column is used for identification of conditions that make the equipment not ready/available for readiness reporting purposes or denies use of the equipment until corrective maintenance is performed.
- d. If your equipment fails to operate after PMCS is performed, immediately report this condition to your supervisor.
- e. Perform weekly as well as before operation if you are the assigned operator and have not operated the item since the last weekly or if you are operating the item for the first time.
- f. Item number column. Item numbers are assigned in chronological ascending sequence regardless of interval designation. These numbers are used for your "TM Number" column on DA Form 2404, Equipment Inspection and Maintenance Worksheet in recording results of PMCS.
- g. Interval columns. This column determines the time period designated to perform your PMCS.
- h. Item to be inspected and procedures column. This column lists functional groups and their respective assemblies and subassemblies as shown in the Maintenance Allocation Chart (Appendix B). The appropriate check or service procedure follows the specific item to be inspected.
- i. Equipment is not ready/available if: column. This column indicates the reason or cause why your equipment is not ready/available to perform its primary mission.
- j. List of tools and materials required for PMCS is as follows:

<u>Item</u>	<u>Quantity</u>
Flat Tip Screwdriver	1 ea
Lens Tissue (Item 23, Appendix E)	ar
Lens Cleaner (Item 4, Appendix E)	ar

Table 4-1. OPERATOR PREVENTIVE MAINTENANCE CHECKS AND SERVICES

B - Before  
D - During  
A - After

W - Weekly  
M - Monthly  
Q - Quarterly

AN - Annually  
S - Semiannually  
BI - Biennially

(Number) - Hundreds of Hours

ITEM NO.	INTERVAL	ITEM TO BE INSPECTED  PROCEDURE	For Readiness Reporting, Equipment Is Not Ready/ Available If:
1	B	<p><b>STEREOMETER PARALLAX BAR</b></p> <p><u>Inspect Parallax Bar.</u></p> <ol style="list-style-type: none"> <li>Place transport case on work surface and open.</li> </ol>  <ol style="list-style-type: none"> <li>Inspect for completeness: two optical dots, wrench, four attachment screws and stereometer.</li> </ol>  <ol style="list-style-type: none"> <li>Attach optical dot to stereometer with four attachment screws.</li> </ol>	Two optical dots missing or broken.

Table 4-1. OPERATOR PREVENTIVE MAINTENANCE CHECKS AND SERVICES - Cont

B - Before  
D - During  
A - After

W - Weekly  
M - Monthly  
Q - Quarterly

AN - Annually  
S - Semiannually  
BI - Biennially

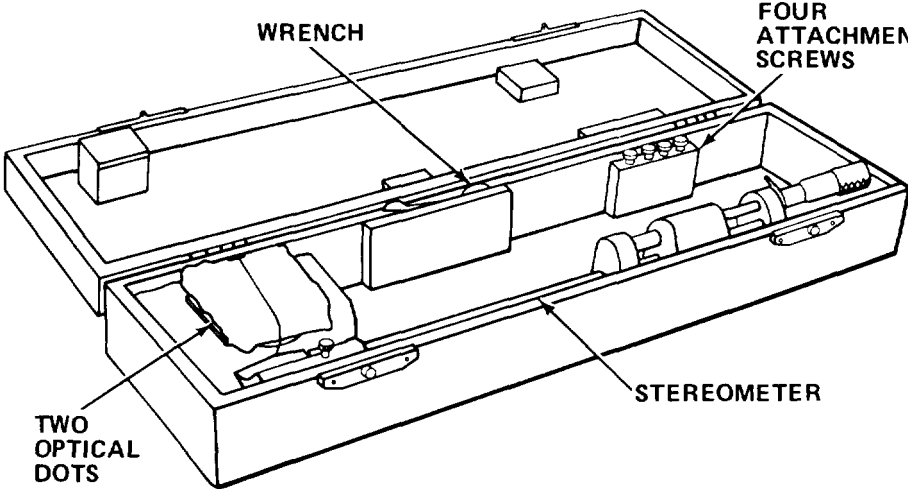
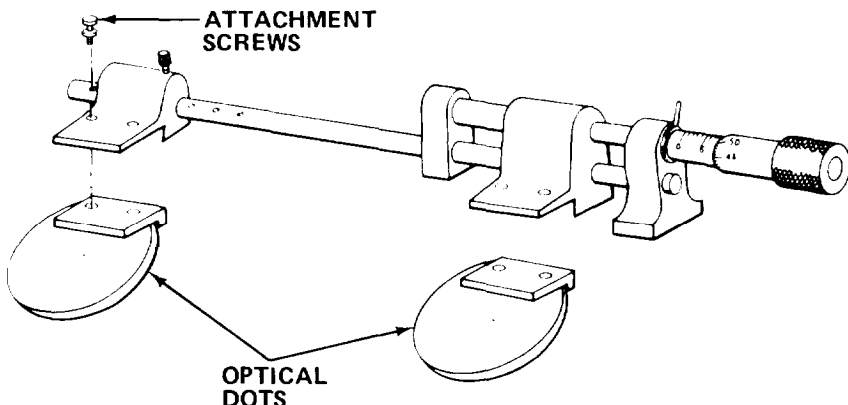
(Number) . Hundreds of Hours

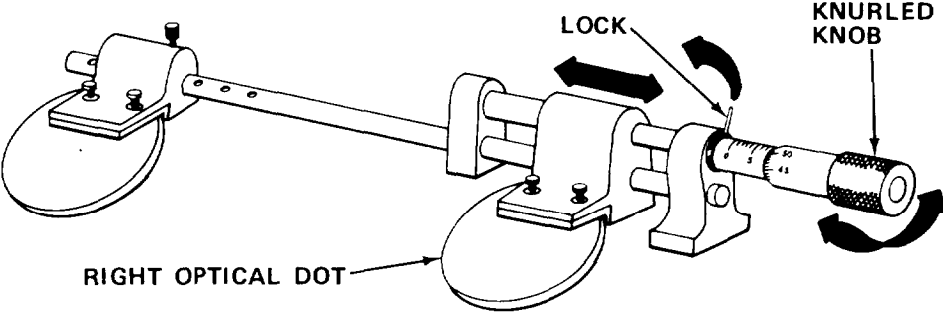
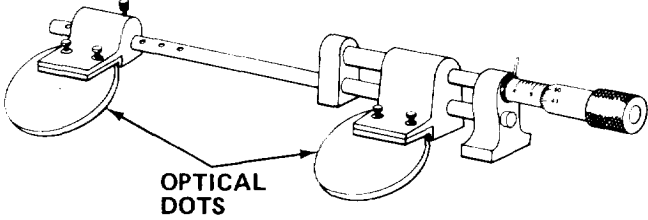
ITEM NO.	INTERVAL	ITEM TO BE INSPECTED  PROCEDURE	For Readiness Reporting, Equipment Is Not Ready/ Available If:
<b>STEREOMETER PARALLAX BAR - Cont</b>			
1	B	<p data-bbox="277 506 716 534"><u>Inspect Parallax Bar - Cont</u></p> <p data-bbox="277 570 1120 629">4. Inspect optical dots for chips, fingerprints, or cracks.</p>  <p data-bbox="277 1012 1080 1134">5. Unlock micrometer barrel by releasing lock. Rotate knurled knob and observe free movement of mount for right optical dot against spring tension.</p>	
2	B	<p data-bbox="277 1172 596 1200"><u>Clean Parallax Bar.</u></p> <p data-bbox="277 1236 1058 1264">1. Moisten clean lens tissue with lens cleaner.</p>  <p data-bbox="277 1549 1136 1859">2. Wipe optical dot surfaces with moistened tissue using circular motion, starting from center and moving toward edge.</p> <p data-bbox="277 1683 1120 1772">3. Wipe optical dot glass surfaces with fresh, dry tissue using a circular motion, starting from center and moving toward edge.</p> <p data-bbox="277 1804 1136 1859">4. Wipe exposed metal surfaces with clean tissue to remove dust or dirt.</p>	



4-6. OPERATION UNDER USUAL CONDITIONS.

4-6.1 Assembly and Preparation For Use.

- a. Place transport case on work surface.

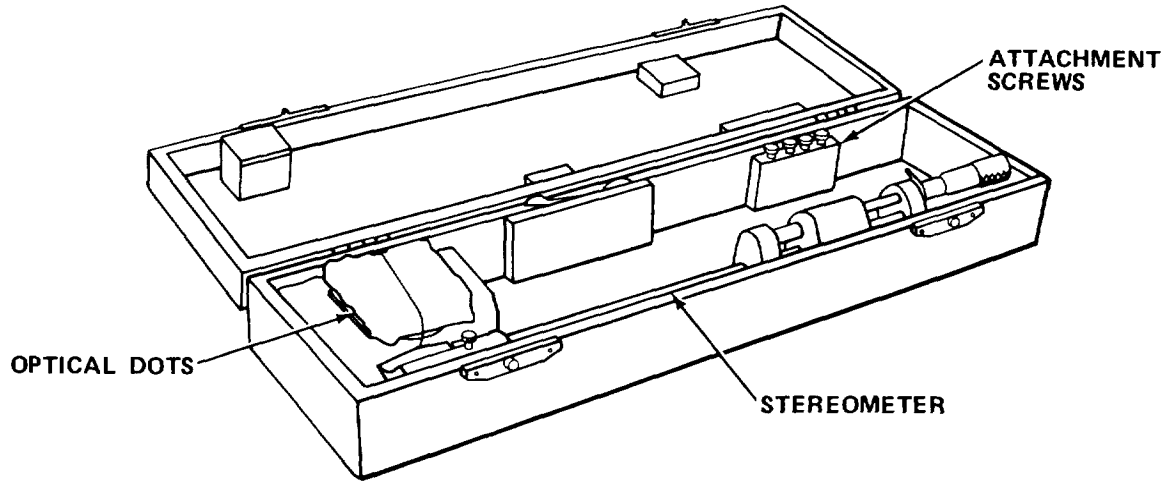

- b. Remove optical dots.
- c. Remove attachment screws.
- d. Remove stereometer.

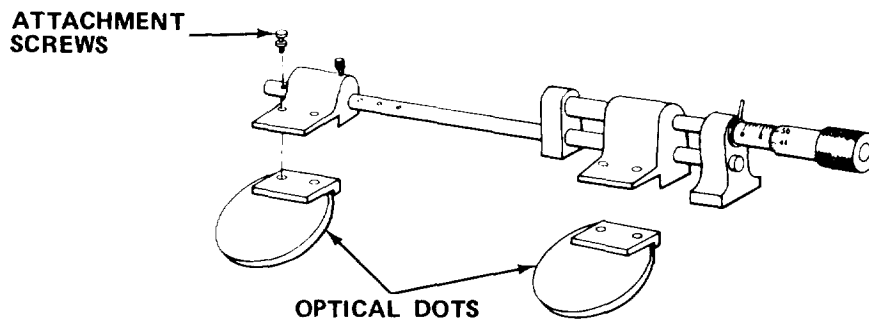

- e. Aligne optical dots with mounts and secure with attachment screws.

4-6.2 Operating Procedures.

- a. Aline stereo-pair photographs on work surface.

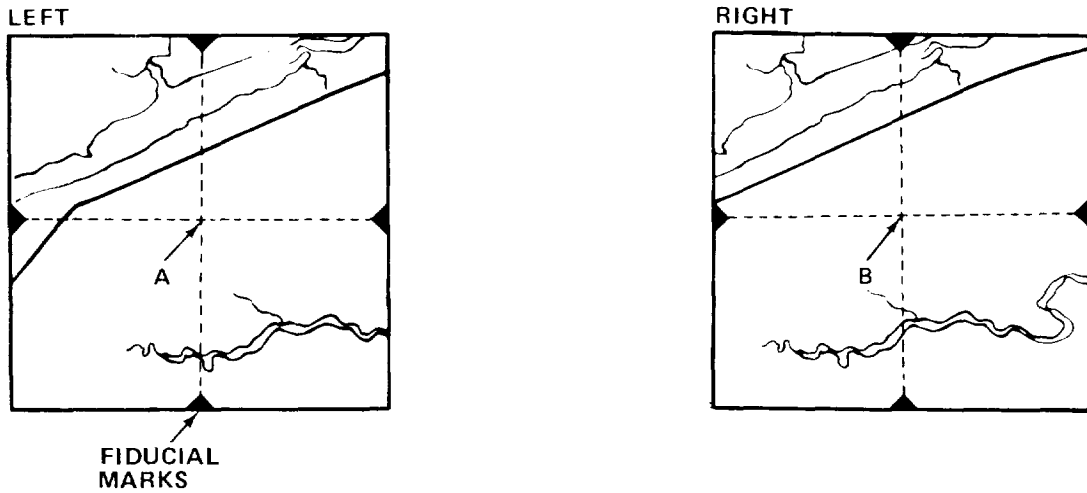

- (1) Prick center of each photograph with pin at A and B.

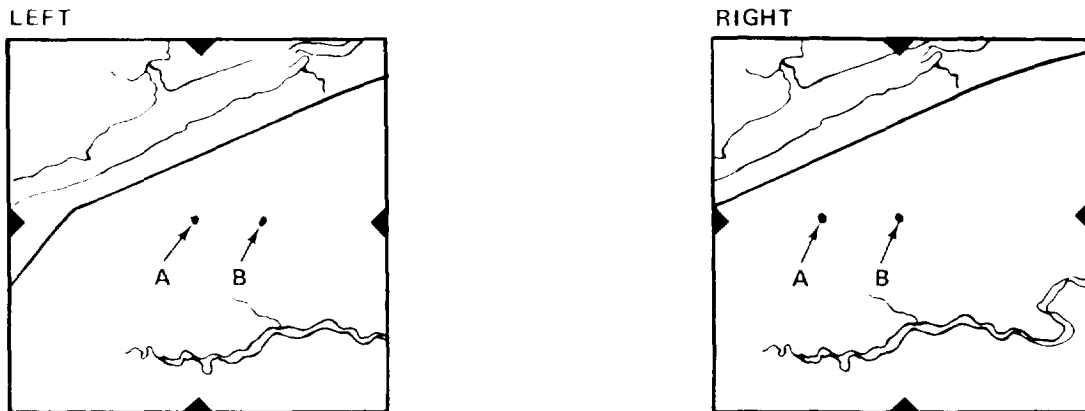

- (2) Observe photographic point designated as B, and prick this point on left photograph (point B1).

- (3) Observe photographic point designated as A, and prick this point on right photograph (point A1).

- (4) Place stereoscope over photographs, and follow stereoscope instructions to obtain stereoscopic view of photograph.

- b. Set stereometer to base of photographs.

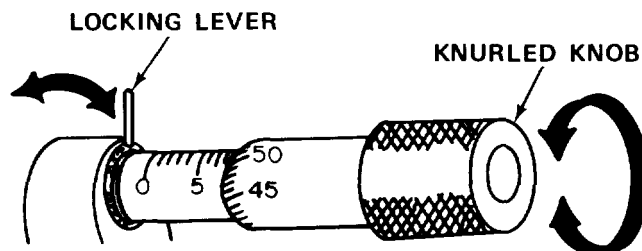

- (1) Position micrometer at midscale.
- (2) Position left optical dot over point A.

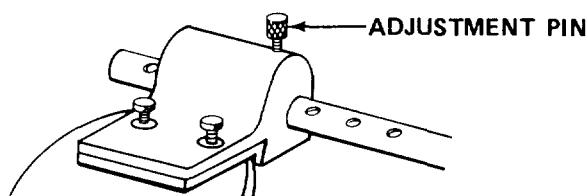

(3) Lift adjustment pin and position right optical glass mount at adjustment hole closest to point A1.

(4) Position left optical dot over point A. Unlock locking lever on micrometer. Then turn knurled knob on micrometer to left or right until right optical dot is over point A1.

c. Make datum plane reading.

(1) Choose known elevation point that is on both photographs (or point that will be at reference elevation).

(2) Place left optical dot over this point on left photograph.

(3) Place right optical dot over same point on right photograph.

(4) Look through stereoscope and turn micrometer knurled knob until two optical dots are seen as one dot that looks as if it contacts ground on reference point.

d. Read micrometer scale.

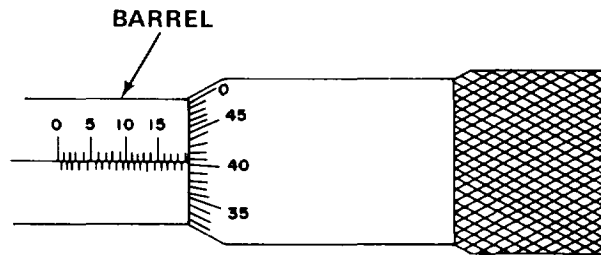

- (1) Read largest number visible on barrel, i.e., 15.
  - (2) Count full divisions visible between 15 and 20, i.e., 3.
  - (3) Add:  $15 + 3 = 18$ .
  - (4) Marks to below the line indicate 0.5. Mark between 18 and 19 is visible, so add 0.5, i.e., 18.5
  - (5) Read hundredth's scale, i.e., 0.41.
  - (6) Total reading:  $18 + 0.5 + 0.41 = 18.91$ .
- e. Make elevation reading.
- (1) Place left optical dot over point for which elevation is to be determined.
  - (2) Place right optical dot over same point in right photograph.
  - (3) Look through stereoscope and turn micrometer knurled knob until optical dots are fused and apparently contact ground at point.
  - (4) Read micrometer scale, and record reading to hundredths of millimeters.
- f. Determine differential parallax.
- (1) When elevation reading at unknown point is smaller than datum reading, assign minus value (lower elevation).
  - (2) When elevation reading at unknown point is greater than datum reading, assign plus value (higher elevation).
  - (3) Determine numerical difference between datum reading and elevation reading. This number is differential parallax ( $\Delta p$ ).

g. Compute elevation. When numerical value and sign of differential parallax have been determined, height above or below datum may be computed:

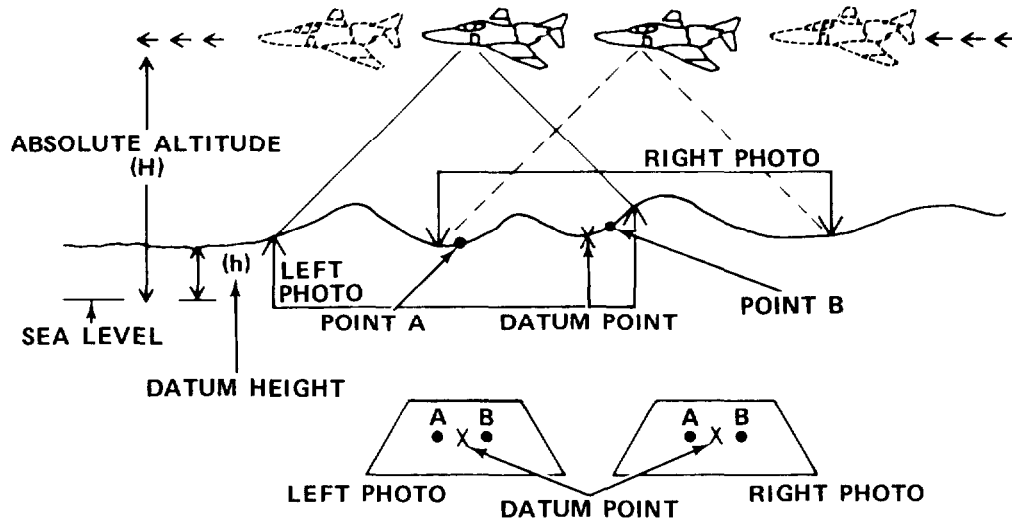

$$h = \frac{H \Delta p}{b + \Delta p}$$

Where:

$h$  = Difference in elevation between datum plane and point in feet.

$H$  = Absolute altitude in feet.

$\Delta p$  = Differential parallax in millimeters (to nearest 0.01 mm).

$b$  = Distance between principal points of photographs in millimeters.

h. Compute relative elevation. Small changes in elevation from one point to another point may be computed using the following formula:

$$\frac{h}{\Delta p} = \frac{h^1}{\Delta p^1} \quad \text{or} \quad h^1 = \frac{h \Delta p^1}{\Delta p}$$

$h$  = Difference in elevation between datum plane and first point in feet.

$\Delta p$  = Differential parallax used for first determination.

$h^1$  = Difference in elevation between datum and second point.

$\Delta p^1$  = Differential parallax for second point measured in millimeters.

Example (1):

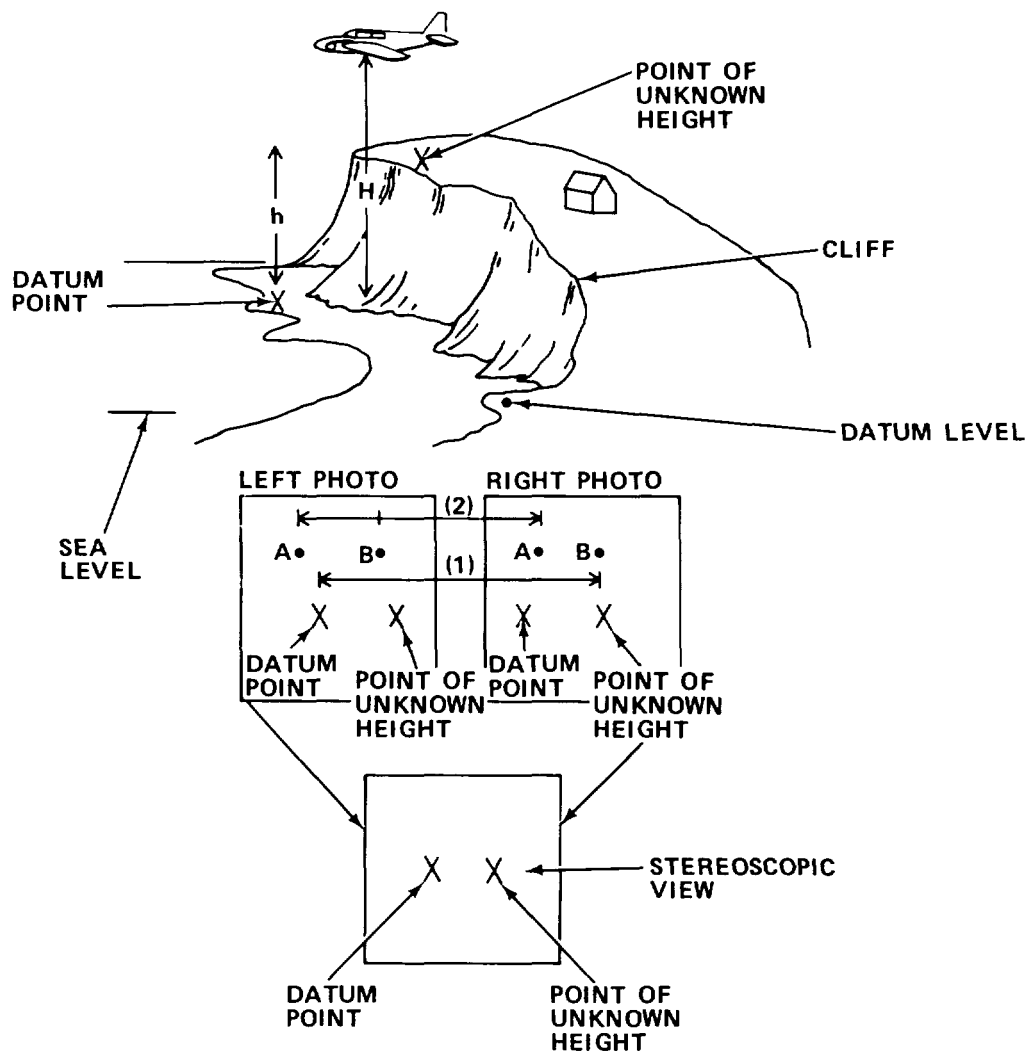

(1) Check distance between datum and point to be measured. (Must be between 8-1/2 in. and 4-1/2 in.)

(2) Make datum plane reading (4-6.2c). Micrometer reads 3.38mm.

- (3) Make elevation reading (4-6.2e). Micrometer reads 3.98 mm.
- (4) Subtract readings. Difference is 0.60 mm. Reading is increased so sign is + (plus).
- (5) Measure distance (principle point separation). Distance is 76.2 mm.
- (6) Height of aircraft was 5000 ft above sea level.

$$H = 5000 \text{ ft}$$

$$\Delta p = +0.60 \text{ mm}$$

$$b = 76.2 \text{ mm}$$

$$h = \frac{H \Delta p}{b + \Delta p}$$

$$h = \frac{5000 \times 0.60}{76.2 + 0.60} = \frac{3000}{76.80} = 39 \text{ ft}$$

Example (2): Using same photographs, determine height of building.

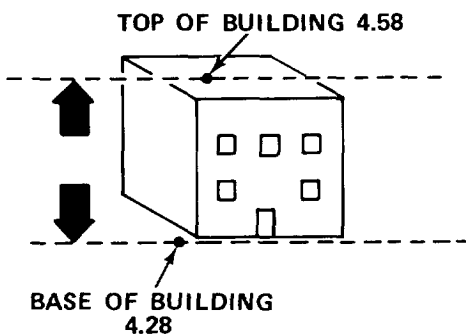

- 1. Make datum reading at base of building. Reading is 4.28 mm.
- 2. Make elevation reading at top of building. Reading is 4.58 mm.

Base Height Above Datum

$$h = 39 \text{ ft}$$

$$\Delta p = 0.60 \text{ mm}$$

$$\Delta p^1 = 0.90 \text{ mm}$$

$$h^1 = \frac{h \Delta p^1}{\Delta p}$$

$$h^1 = \frac{39 \times 0.90}{0.60} = 58 \text{ ft Above Datum}$$

Building Top Above Datum

$$h = 39 \text{ ft}$$

$$\Delta p = 0.60 \text{ mm}$$

$$\Delta p^1 = 1.20 \text{ mm}$$

$$4.58 \text{ m} - 4.28 \text{ m} = 0.30 \text{ mm}$$

$$0.90 \text{ mm} + 0.30 \text{ mm} = 1.20 \text{ mm}$$

$$h^1 = \frac{h \Delta p^1}{\Delta p}$$

$$h^1 = \frac{39 \times 1.20}{0.60} = 78 \text{ ft Above Datum}$$

Height of Building (78 ft - 58 ft) = 20 ft



**4-6.3 Preparation For Movement.**

- a. Place transport case on work surface.
- b. Remove two attachment screws on each optical glass.
- c. Place screws in transport case.
- d. Pad optical glass and place in case.
- e. Place stereometer in case.
- f. Close lid and check that lid latches.

**4-7. OPERATION UNDER UNUSUAL CONDITIONS.** The stereometer can be used under any condition that permits use of a stereoscope.

### **Section III OPERATOR MAINTENANCE**

**4-8. LUBRICATION INSTRUCTIONS.** This equipment does not require lubrication.

**4-9. TROUBLESHOOTING.** There are no operator troubleshooting procedures assigned for this equipment.

**4-10. MAINTENANCE PROCEDURES.** There are no operator maintenance procedures assigned for this equipment.

### **Section IV ORGANIZATIONAL MAINTENANCE**

**4-11. LUBRICATION INSTRUCTIONS.** This equipment does not require lubrication.

**4-12. REPAIR PARTS, SPECIAL TOOLS; TEST, MEASUREMENT, AND DIAGNOSTIC EQUIPMENT (TMDE); AND SUPPORT EQUIPMENT.** These items are not required for this equipment.

**4-13. SERVICE UPON RECEIPT.**

**4-13.1 Checking Unpacked Equipment.**

a. Inspect the equipment for damage incurred during shipment. If equipment has been damaged, report the damage on DD Form 6, Packing Improvement Report.

b. Check the equipment against the packing list to see if the shipment is complete. Report all discrepancies in accordance with the instructions of DA Pam 738-750.

c. Check to see whether the equipment has been modified.

**4-14. ORGANIZATIONAL PREVENTIVE MAINTENANCE CHECKS AND SERVICES.** There are no organizational PMCS procedures assigned for this equipment.

**4-15. ORGANIZATIONAL TROUBLESHOOTING PROCEDURES.** There are no organizational troubleshooting procedures assigned for this equipment.

**4-16. MAINTENANCE PROCEDURES.** There are no organizational maintenance procedures assigned for this equipment.

**4-17. PREPARATION FOR STORAGE OR SHIPMENT.** Contact your battalion for packing and shipping instructions.

#### **Section V DIRECT/GENERAL SUPPORT MAINTENANCE**

There are no direct/general support maintenance procedures assigned for this equipment.



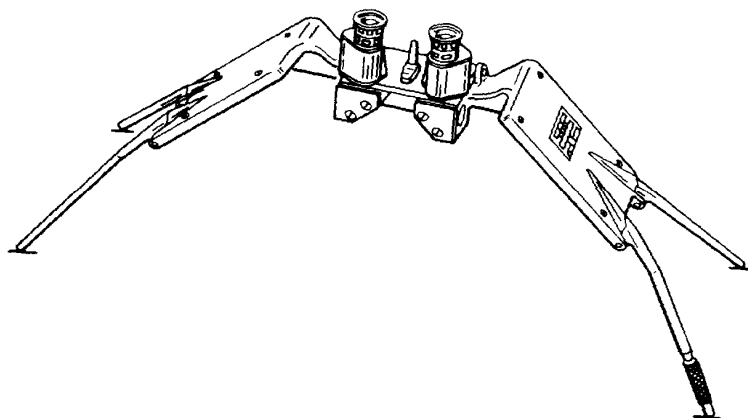

CHAPTER 5

LENS-PRISM-MIRROR STEREOSCOPE

Section I INTRODUCTION

5-1. GENERAL INFORMATION.

5-1.1 Scope.

- a. Model Number and Equipment Name. Lens-Prism-Mirror Stereoscope.
- b. Purpose of Equipment. Stereoscopic viewing of stereo-pair photographs and to determine heights (when used with parallax bar).

5-1.2 Glossary.

Diopter . . . . .	Measurement of lens Power and refraction.
Fiducial Mark. . . . .	Marks on edges of aerial photographs used to determine center of photograph.
Interpupillary Distance . . . . .	Distance between center of observer's eyes.
Principal Point of Photograph . . . . .	Center of photographic image.
Stereo-Pair Photograph . . . . .	Photographs taken of same object or area from different positions.
Stereoscopic . . . . .	An apparent three-dimensional image obtained when viewing stereo-pair photographs.

5-2. EQUIPMENT DESCRIPTION.

5-2.1 Equipment Characteristics, Capabilities, and Features.

Removable binocular assembly permits full stereoscopic viewing of 9 in. X 9 in. (22.9 cm x 22.9 cm) aerial photographs.

- b. Four-power magnification with binocular assembly.
- c. Lightweight.
- d. Folds for storage.
- e. Adjusts for uneven surface.

5-2.2 Equipment Data.

Stereo Base	10 in. (25.4 cm)
Interpupillary Distance	Fixed
Focal Length	11-1/2 in. (13.97 cm)
Common Field of View	5 in. (12.7 cm)
Weight	2-1/2 lbs (1.14 kg)
Unfolded Dimensions	6 in. X 7 in. X 19 in. (15.24 cm X 17.78 cm X 48.26 cm)
Binocular Magnification	4X
Eyepiece Adjustment	±5 diopters

**5-3. TECHNICAL PRINCIPLES OF OPERATION.** Principles of operation are combined with operator's controls and indicators for this equipment.

Section II OPERATING INSTRUCTIONS

5-4. DESCRIPTION AND USE OF OPERATOR'S CONTROLS AND INDICATORS

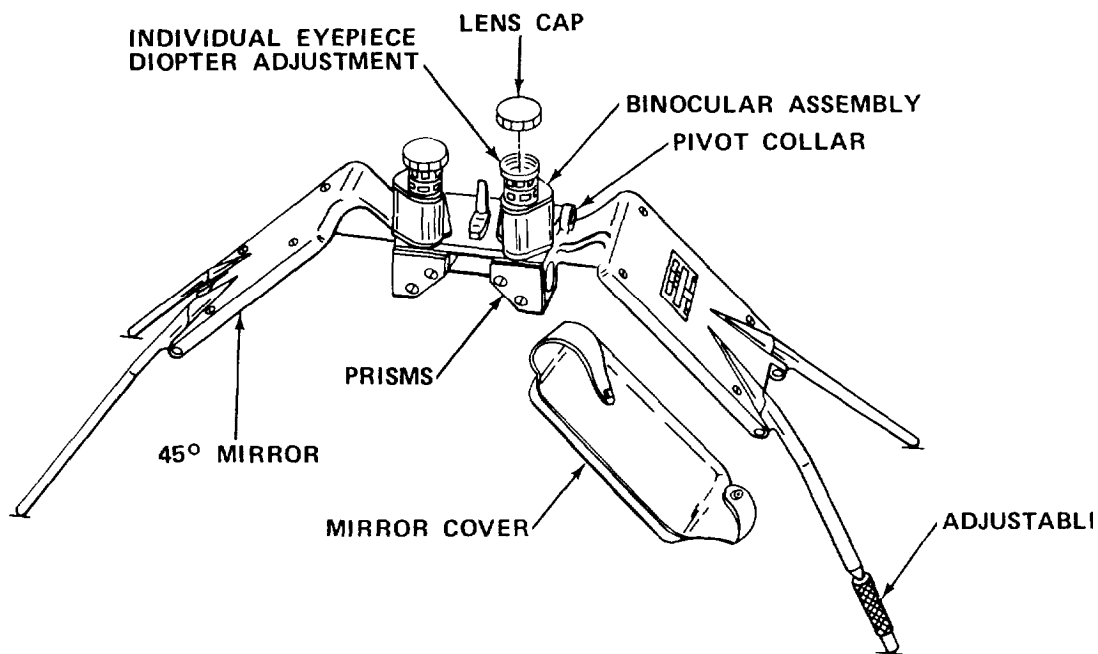

Control or Indicator	Function
Lens Cap	Protects optics.
Individual Eyepiece Diopter Adjustment	Compensates for operator's vision.
Binocular Assembly	Four-power magnification of view field.
Pivot Collar	Holds binocular assembly to frame. Permits operator to view unmagnified image by removing binocular assembly.
Prisms	Direct right and left line of sight to right and left mirrors.
45-Degree Mirrors	Reflect right and left photographs to right and left line of sight.

Control or Indicator	Function
Mirror Covers	Protect mirrors when storing stereoscope and when stereoscope is not in use.
Adjustable Leg	Permits stereoscope to be used on uneven surface.

**5-5. OPERATOR PREVENTIVE MAINTENANCE CHECKS AND SERVICES.**

- a. Before You Operate. Always keep in mind the WARNINGS and CAUTIONS. Perform your before (B) PMCS.
- b. While You Operate. Always keep in mind the WARNINGS and CAUTIONS. Perform your during (D) PMCS.
- c. After You Operate. Be sure to perform your after (A) PMCS.
- d. If Your Equipment Fails to Operate. Troubleshoot with proper equipment. Report any deficiencies using the proper forms. See DA Pam 738-750.

**5-5.1 PMCS Procedures.**

- a. PMCS are designed to keep the equipment in good working condition by performing periodic service tasks.
- b. Service intervals provide you, the operator, with time schedules that determine when to perform specified service tasks.
- c. The “Equipment is Not Ready/Available If” column is used for identification of conditions that make the equipment not ready/available for readiness reporting purposes or denies use of the equipment until corrective maintenance is performed.
- d. If your equipment fails to operate after PMCS is performed, immediately report this condition to your supervisor.
- e. Perform weekly as well as before operation if you are the assigned operator and have not operated the item since the last weekly or if you are operating the item for the first time.
- f. Item number column. Item numbers are assigned in chronological ascending sequence regardless of interval designation. These numbers are used for your “TM Number” column on DA Form 2404, Equipment Inspection and Maintenance Worksheet in recording results of PMCS.



g. Interval columns. This column determines the time period designated to perform your PMCS.

h. Item to be inspected and procedures column. This column lists functional groups and their respective assemblies and subassemblies as shown in the Maintenance Allocation Chart (Appendix B). The appropriate check or service procedure follows the specific item to be inspected.

i. Equipment is not ready/available if: column. This column indicates the reason or cause why your equipment is not ready/available to perform its primary mission.

j. List of tools and materials required for PMCS is as follows:

<u>Item</u>	<u>Quantity</u>
Watchmaker's Blower	1 ea
Lens Tissue (Item 23, Appendix E)	ar
Optical Lens Cleaner (Item 4, Appendix E)	ar

Table 5-1. OPERATOR PREVENTIVE MAINTENANCE CHECKS AND SERVICES

NOTE

If the equipment must be kept in continuous operation, check and service only those items that can safely be checked and serviced without disturbing operation. Make the complete checks and services when the equipment can be shut down.

B - Before  
D - During  
A - After

W - Weekly  
M - Monthly  
Q - Quarterly

AN - Annually  
S - Semiannually  
BI - Biennially

(Number) - Hundreds of Hours

ITEM NO.	INTERVAL	ITEM TO BE INSPECTED  PROCEDURE	For Readiness Reporting, Equipment is Not Ready/ Available If:
1	B	<p><b>LENS-PRISM-MIRROR STEREOSCOPE</b></p> <p><u>Inspect Stereoscope.</u></p>  <ol style="list-style-type: none"> <li>1. Inspect frame for bending and twisting.</li> <li>2. Inspect mirror covers for tears, broken snaps, and fungi.</li> <li>3. Inspect legs for bends, breaks, and loose hinges.</li> <li>4. Inspect mirrors for cracks, chips, and defective silvering.</li> <li>5. Place white sheet of paper under mirrors and look through optical system to detect chips, cracks, or fungi.</li> </ol>	<p>Mirrors are broken.</p>

Table 5-1. OPERATOR PREVENTIVE MAINTENANCE CHECKS AND SERVICES - Cont

B - Before  
D - During  
A - After

W - Weekly  
M - Monthly  
Q - Quarterly

AN - Annually  
S - Semiannually  
BI - Biennially

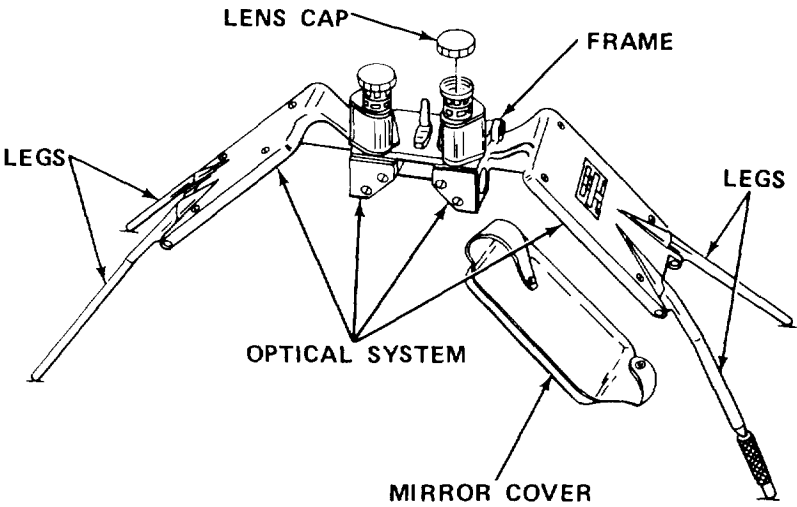
(Number) - Hundreds of Hours

ITEM NO.	INTERVAL	ITEM TO BE INSPECTED	PROCEDURE	For Readiness Reporting, Equipment is Not Ready/ Available If:
2	B	<b>LENS-PRISM-MIRROR STEREOSCOPE - Cont</b>	Clean Stereoscope.	
			<b><u>CAUTION</u></b>	
			<ul style="list-style-type: none"> <li>● Do not touch optical or mirror surfaces with bare fingers to prevent damage optical surfaces.</li> <li>● Do not wipe dry optical surfaces with lens tissue. Do not reuse lens tissue on more than one lens, or glass surfaces will be scratched.</li> </ul>	
			 <p>The diagram shows a stereoscope with two eyepieces and a central prism assembly. Two arrows point to the lens surfaces, labeled 'OPTICAL SURFACES'. Another arrow points to a textured grip on the right eyepiece, labeled 'KNURLED SLEEVE'.</p>	

Table 5-1. OPERATOR PREVENTIVE MAINTENANCE CHECKS AND SERVICES - Cont

B - Before  
D - During  
A - After

W - Weekly  
M - Monthly  
Q - Quarterly

AN - Annually  
S - Semiannually  
BI - Biennially

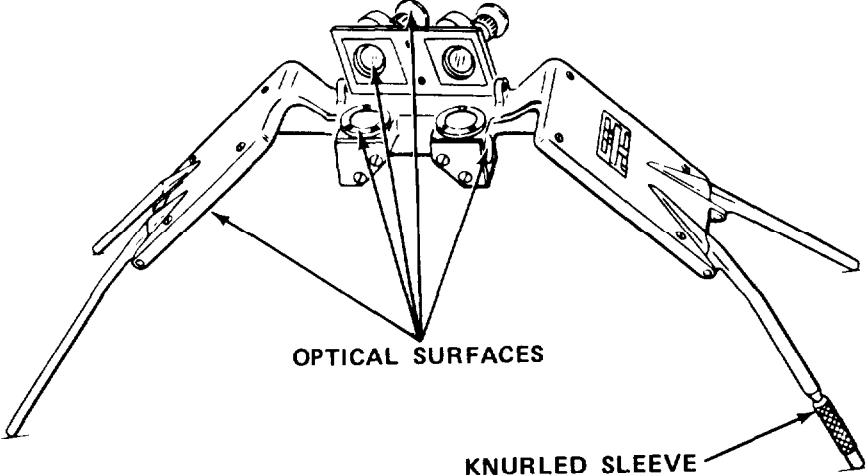
(Number) - Hundreds of Hours

ITEM NO.	INTERVAL	ITEM TO BE INSPECTED  PROCEDURE	For Readiness Reporting, Equipment is Not Ready/ Available If:
2	B	<p><b><u>LENS-PRISM-MIRROR STEREOSCOPE - Cont</u></b></p> <p><u>Clean Stereoscope - Cont</u></p> <ol style="list-style-type: none"> <li>1. Blow dirt and dust from optical surface with watchmaker's blower.</li> <li>2. Moisten lens tissue with optical lens cleaner, and wipe one optical surface with circular motion from center toward edges. Discard tissue.</li> <li>3. Dry optical surface by wiping with clean lens tissue using circular motion from center toward edges. Discard tissue.</li> <li>4. Repeat procedure on each remaining optical surface and two mirrors.</li> <li>5. Turn leg adjustment knurled sleeve to full right, then to full left, to clear threads.</li> </ol>	

**5-6. OPERATION UNDER USUAL CONDITIONS.**

**5-6.1 Operating Procedures.**

a. Remove stereoscope frame and binocular assembly from case, and place on work surface.

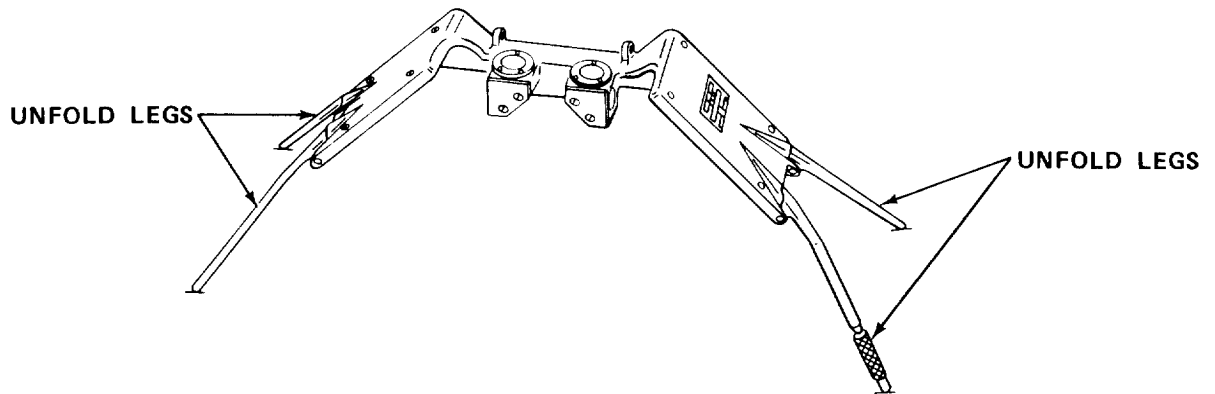

b. Unfold four legs to full extension.

c. Unsnap mirror covers and remove.

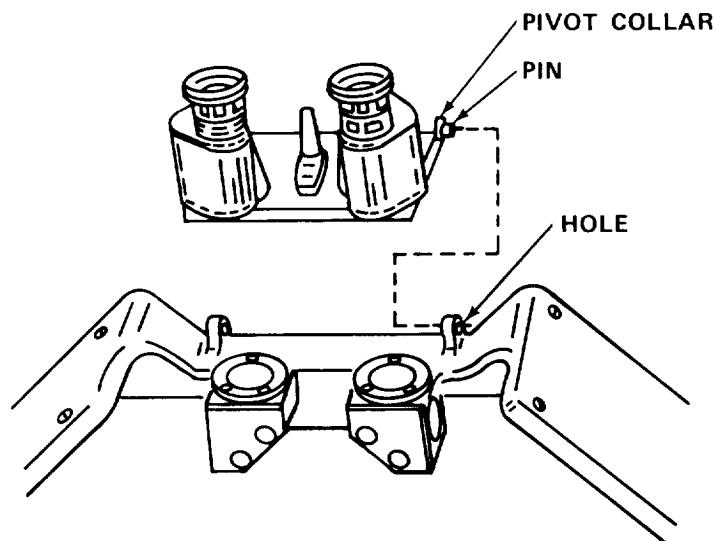

d. Squeeze pivot collars between fingers, and place binocular assembly on frame so that pin will enter holes. Release pivot collars.

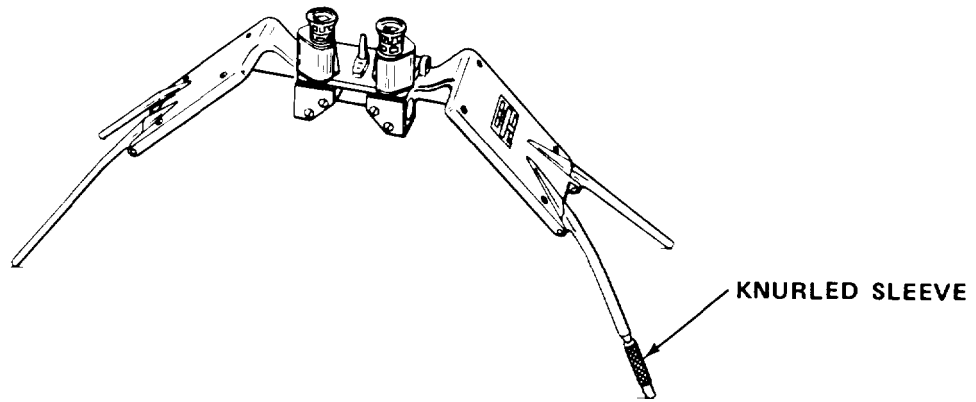

e. Adjust leg by turning knurled sleeve until stereoscope is level.

f. Adjust eyepiece to individual operator's eyes by placing stereo-pair photographs under stereoscope with left photograph visible in left eyepiece and right photograph visible in right eyepiece.

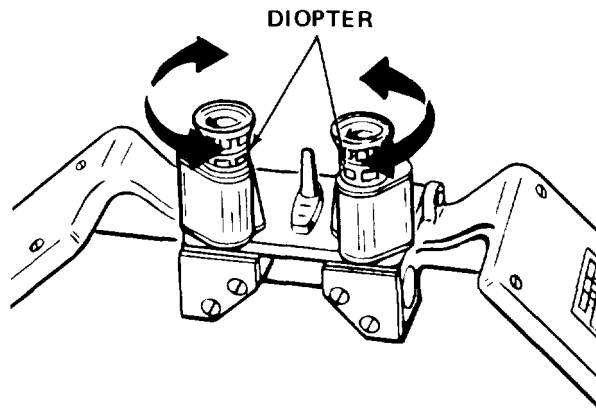

g. Close one eye and turn diopter ring until vision is clear. Close other eye and adjust second diopter ring.

h. Aline stereo-pair photographs for stereoscopic viewing.

**NOTE**

Alinement of fiducial marks and principal points is easier if binocular assembly is tilted back and photographs are viewed through lens-prism system.

- i. Check that right and left photographs are not interchanged.
- j. Determine that principal point in each photograph is visible in other photographs.
- k. Adjust photographs to a common base line.
- l. Adjust stereoscope base line parallel to photograph base line with proper separation.
- m. Replace mirror covers when finished.

**NOTE**

If stereoscope is not to be used immediately, replace stereoscope in case.

**5-7. OPERATION UNDER UNUSUAL CONDITIONS.** This equipment is designed for operation only in a controlled environment.

**Section III OPERATOR MAINTENANCE**

**5-8. LUBRICATION INSTRUCTIONS.** This equipment does not require lubrication.

**5-9. TROUBLESHOOTING PROCEDURES.** There are no operator troubleshooting procedures assigned for this equipment.

**5-10. MAINTENANCE PROCEDURES.**

a. This section contains instructions covering operator maintenance functions for the lens-prism-mirror stereoscope. Personnel required are listed only if the task requires more than one.

b. After completing each maintenance procedure, perform operational check to be sure that equipment is properly functioning.

**INDEX**

PROCEDURES	PARAGRAPH
Adjust Mirror . . . . .	5-10.1

5-10.1 Adjust Mirror,

MOS: 81Q, Terrain Analyst

TOOLS: Jeweler's Screwdriver Set

- a. Remove binocular assembly by pinching pivot collars with fingers and lifting free.
- b. Stretch piece of string under stereoscope so that string may be observed through both prisms.
- c. Keep stereoscope centered over string and move legs horizontally to right or left until string appears to be one clear line.
- d. Keep eyes close to lenses and look to right, then left. String should remain one clear line. If line is bent or offset, adjust mirrors.

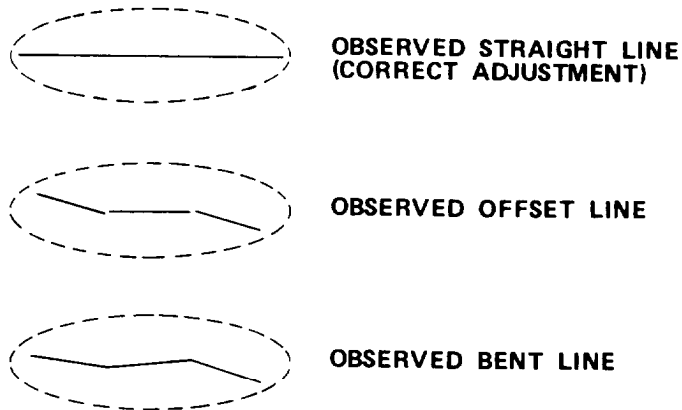
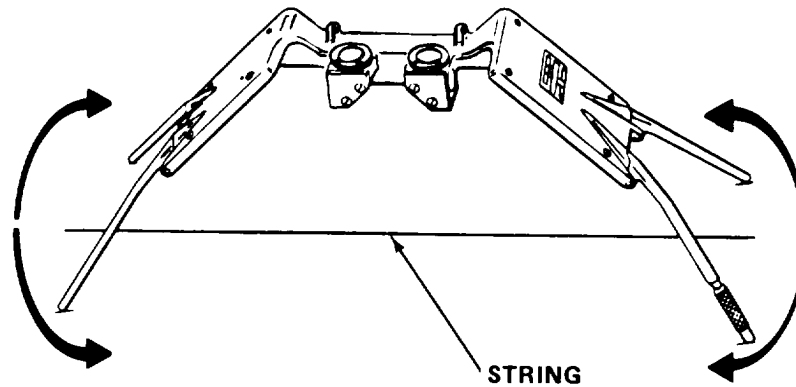



**CAUTION**

To prevent damage to mirrors, do not overtighten screws.

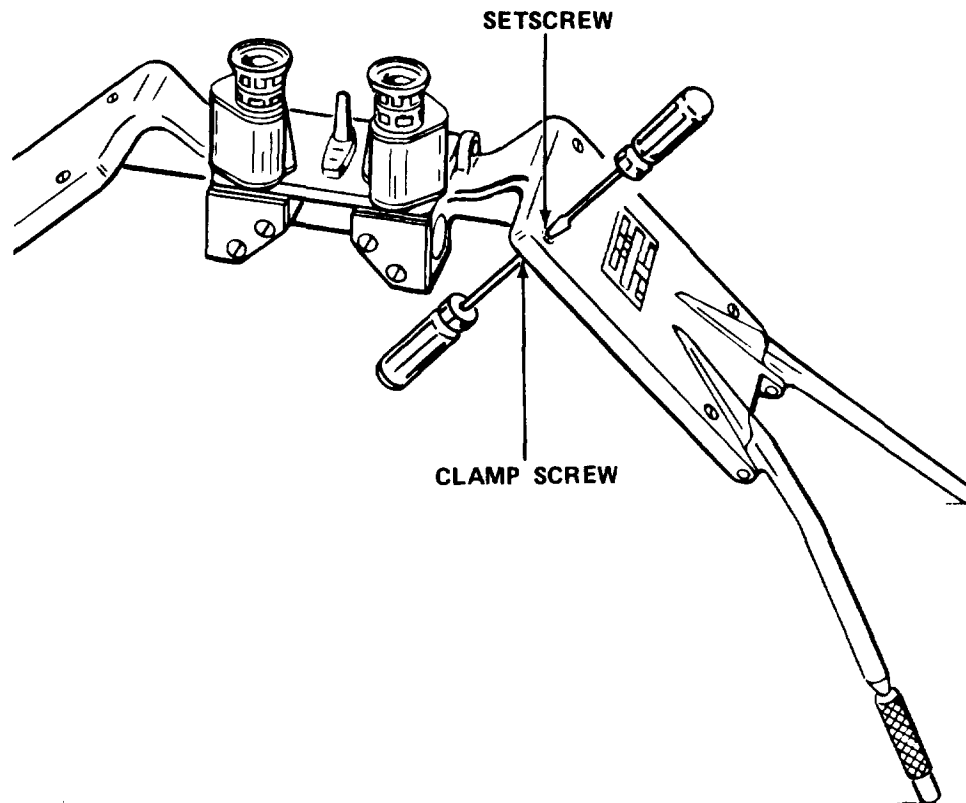

- e. Loosen setscrew and tighten clamp screw an equal amount. Observe line. If improvement is noted, continue loosening setscrew and tightening clamp screw until error is removed. If condition is worse, loosen clamp screw and tighten setscrew. If improvement is noted, continue adjustment until error is removed. If no improvement is noted, return setscrew and clamp screw to original positions. When improvement stops, retain last setting.
- f. Loosen or tighten setscrew and clamp screw equal amounts until error is removed in other mirror.
- g. Tighten screws firmly and recheck adjustment.

#### Section IV ORGANIZATIONAL MAINTENANCE

**5-11. LUBRICATION INSTRUCTIONS.** This equipment does not require lubrication.

**5-12. REPAIR PARTS, SPECIAL TOOLS; TEST, MEASUREMENT, AND DIAGNOSTIC EQUIPMENT (TMDE); AND SUPPORT EQUIPMENT.** These items are not required for this equipment.

**5-13. SERVICE UPON RECEIPT.**

5-13.1 Checking Unpacked Equipment.

a. Inspect the equipment for damage incurred during shipment. If equipment has been damaged, report the damage on DD Form 6, Packing Improvement Report.

b. Check the equipment against the packing list to see if the shipment is complete. Report all discrepancies in accordance with the instructions of DA Pam 738-750.

c. Check to see whether the equipment has been modified.

**5-14. ORGANIZATIONAL PREVENTIVE MAINTENANCE CHECKS AND SERVICES.** There are no organizational PMCS procedures assigned for this equipment.

**5-15. ORGANIZATIONAL TROUBLESHOOTING PROCEDURES.** There are no organizational troubleshooting procedures assigned for this equipment.

**5-16. MAINTENANCE PROCEDURES.** There are no organizational maintenance procedures assigned for this equipment.

**5-17. PREPARATION FOR STORAGE OR SHIPMENT.** Contact your battalion for packing and shipping instructions.

#### Section V DIRECT/GENERAL SUPPORT MAINTENANCE

There are no direct/general support maintenance procedures assigned for this equipment.



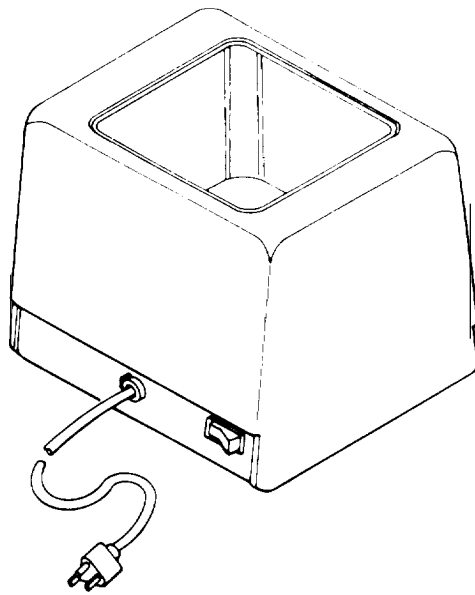

## CHAPTER 6

### ULTRASONIC CLEANER

#### Section I INTRODUCTION

##### 6-1. GENERAL INFORMATION.

###### 6-1.1 Scope.

- a. Model Number and Equipment Name. Model 3069USC3 Ultrasonic Cleaner.
- b. Purpose of Equipment. To clean drafting/drawing pens.

##### 6-2. EQUIPMENT DESCRIPTION.

###### 6-2.1 Equipment Characteristics, Capabilities, and Features.

- a. Cleans without disassembly.
- b. Removes dried ink.
- c. Portable.

6-2.2 Location and Description of Major Components.

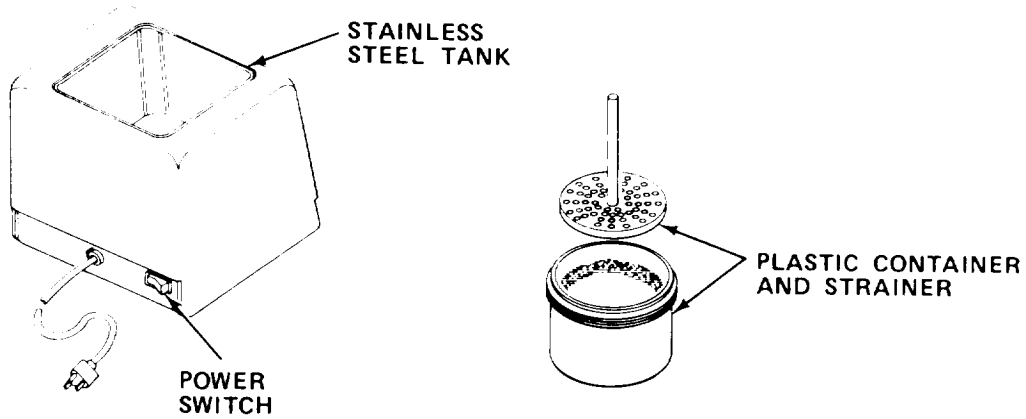

STAINLESS STEEL TANK. Holds water.

PLASTIC CONTAINER AND STRAINER. Holds small parts in solution for cleaning.

POWER SWITCH. Turns machine ON or OFF.

6-2.3 Equipment Data.

Weight	5.51 lbs (2.5 kg)
Power Requirements	115 V, 60 Hz, 60 W

6-3. TECHNICAL PRINCIPLES OF OPERATION.

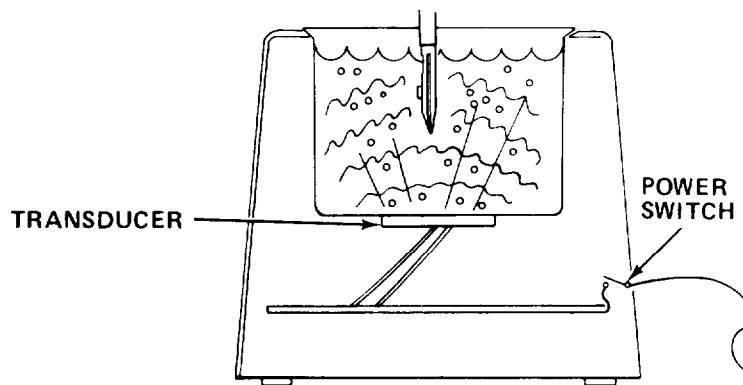

POWER SWITCH. When turned ON, provides power to the transducer.

TRANSDUCER. Generates ultrahigh frequency sound waves.

Section II OPERATING INSTRUCTIONS

6-4. DESCRIPTION AND USE OF OPERATOR'S CONTROLS AND INDICATORS.

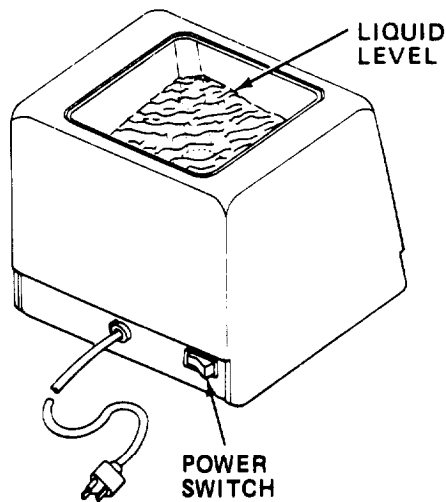

Control or Indicator	Function
Liquid Level	Level of liquid in stainless steel tank must be 1/3 full.
Power Switch	Turns power on or off.

**6-5. OPERATOR PREVENTIVE MAINTENANCE CHECKS AND SERVICES.**

- a. Before You Operate. Always keep in mind the WARNINGS and CAUTIONS. Perform your before (6) PMCS.
- b. While You Operate. Always keep in mind the WARNINGS and CAUTIONS. Perform your during (D) PMCS.
- c. After You Operate. Be sure to perform your after (A) PMCS.
- d. If Your Equipment Fails to Operate. Troubleshoot with proper equipment. Report any deficiencies using the proper forms. See DA Pam 738-750.

**6-5.1 PMCS Procedures.**

- a. PMCS are designed to keep the equipment in good working condition by performing periodic service tasks.
- b. Service intervals provide you, the operator, with time schedules that determine when to perform specified service tasks.
- c. The "Equipment is Not Ready/Available If" column is used for identification of conditions that make the equipment not ready/available for readiness reporting purposes or denies use of the equipment until corrective maintenance is performed.
- d. If your equipment fails to operate after PMCS is performed, immediately report this condition to your supervisor.
- e. Perform weekly as well as before operation if you are the assigned operator and have not operated the item since the last weekly or if you are operating the item for the first time.
- f. Item number column. Item numbers are assigned in chronological ascending sequence regardless of interval designation. These numbers are used for your "TM Number" Column on DA Form 2404, Equipment Inspection and Maintenance Worksheet in recording results of PMCS.
- g. Interval columns. This column determines the time period designated to perform your PMCS.
- h. Item to be inspected and procedures column. This column lists functional groups and their respective assemblies and subassemblies as shown in the Maintenance Allocation Chart (Appendix B). The appropriate check or service procedure follows the specific item to be inspected.
- i. Equipment is not ready/available if: column. This column indicates the reason or cause why your equipment is not ready/available to perform its primary mission.
- j. List of tools and materials required for PMCS is as follows:

<u>Item</u>	<u>Quantity</u>
Cheesecloth (Item 5, Appendix E)	ar



Table 6-1. OPERATOR PREVENTIVE MAINTENANCE CHECKS AND SERVICES

NOTE

If the equipment must be kept in continuous operation, check and service only those items that can safely be checked and serviced without disturbing operation. Make the complete checks and services when the equipment can be shut down.

		B - Before D - During A - After	W - Weekly M - Monthly Q - Quarterly	AN - Annually S - Semiannually BI - Biennially	(Number - Hundreds of Hours	
ITEM NO.	INTERVAL	ITEM TO BE INSPECTED			PROCEDURE	For Readiness Reporting, Equipment Is Not Ready/ Available If:
1	B	<p><u>ULTRASONIC CLEANER</u></p> <p><u>Inspect Cleaner.</u></p> <p style="text-align: center;"><b>WARNING</b></p> <p>Death or serious injury may occur from electrical shock unless power cord is unplugged before servicing.</p> <div style="text-align: center;">  <p>The diagram shows a rectangular ultrasonic cleaner. A label 'ULTRASONIC CLEANER' points to the entire unit. A label 'TANK' points to the top opening of the unit. A label 'POWER CORD' points to the power cord and its plug at the bottom of the unit.</p> </div>				

Table 6-1. OPERATOR PREVENTIVE MAINTENANCE CHECKS AND SERVICES - Cont

B - Before  
D - During  
A - After

W - Weekly  
M - Monthly  
Q - Quarterly

AN - Annually  
S - Semiannually  
BI - Biennially

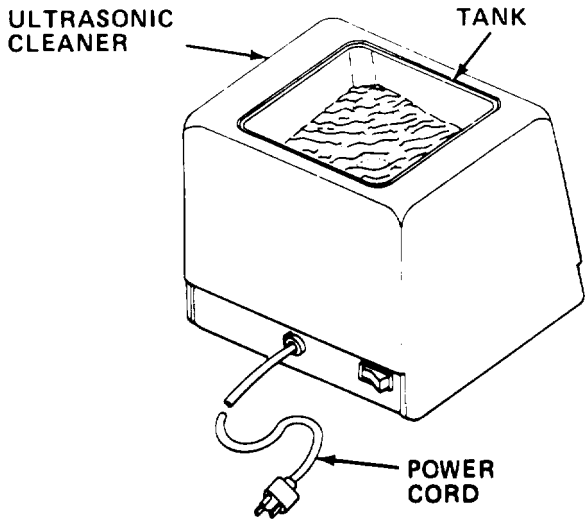
(Number) - Hundreds of Hours

ITEM NO.	INTERVAL	ITEM TO BE INSPECTED  PROCEDURE	For Readiness Reporting, Equipment Is Not Ready/ Available If:
1	B	<p><u>ULTRASONIC CLEANER - Cont</u></p> <p><u>Inspect Cleaner - Cont</u></p> <ol style="list-style-type: none"> <li>1. Check power cord for kinks, frays, or burns. If power cord is defective, notify organizational maintenance.</li> <li>2. Check tank for dirt or chemical residue. Clean tank by wiping with cheesecloth moistened with water.</li> <li>3. Check for agitation of water surface.</li> </ol>	<p>Power cord is damaged.</p> <p>Water surface is not agitating.</p>

## 6-6. OPERATION UNDER USUAL CONDITIONS.

### 6-6.1 Operating Procedure

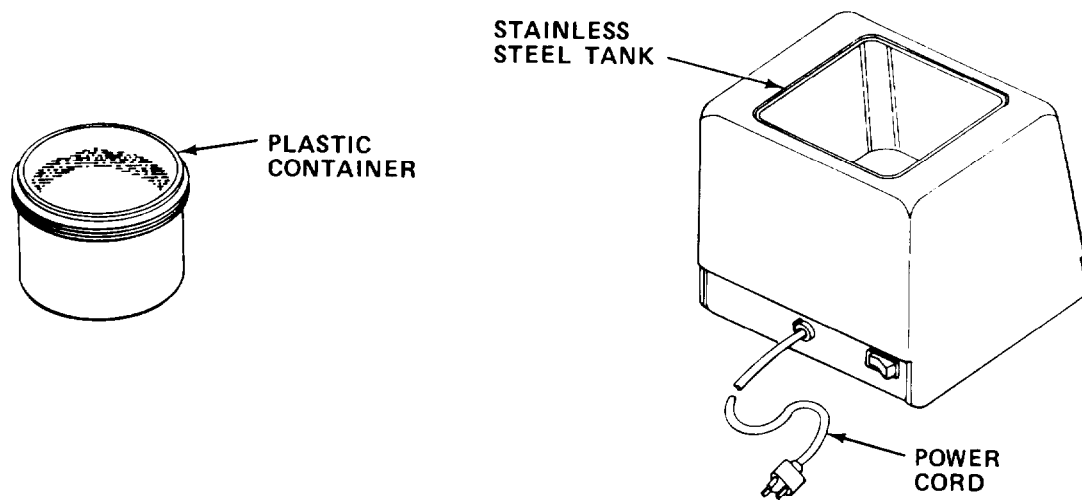

- a. Fill stainless steel tank 1/3 full with fresh, clean water. Fill plastic container with water to within 1/2' in. (12.7 mm) of top.
- b. Add .135 oz (4 ml) of cleaning solution to plastic container.
- c. Plug in power cord to 120 V, 60 Hz grounded outlet.
- d. Turn power on. Be sure water surface in stainless steel tank is agitating.

### WARNING

Do not place fingers in stainless steel tank when ultrasonic cleaner is operating. Cleaning solution may be driven through skin or ultrasonic waves may cause injury to body tissue.

- e. Prepare cleaning solution by operating ultrasonic cleaner for one minute before cleaning pen tips.

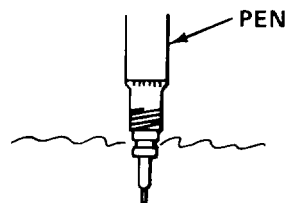

**CAUTION**

Do not immerse pen beyond cap threads. Damage to pen may result.

- f. Dip pen about 3/4 in. (19 mm) in cleaning solution.
- g. Lift pen from cleaning solution. Keeping point downward, shake solution from pen into cheesecloth (Item 5, Appendix E).
- h. Wipe pen.
- i. Draw pen over scrap paper until ink flows freely and shows uniform color,
- j. Turn power off. Unplug power cord.
- k. Dispose of cleaning solution when dirty.

**CAUTION**

Avoid getting water into body of ultrasonic cleaner. Damage to circuit board can result.

- l. Carefully rinse stainless steel tank.
- m. Wipe stainless steel tank dry with cheesecloth (Item 5, Appendix E),

**6-7. OPERATION UNDER UNUSUAL CONDITIONS.** This equipment is designed for operation only in a controlled environment.

**Section III OPERATOR MAINTENANCE**

**6-8. LUBRICATION INSTRUCTIONS.** This equipment does not require lubrication.

**6-9. TROUBLESHOOTING PROCEDURES.** There are no operator troubleshooting procedures assigned for this equipment.

**6-10. MAINTENANCE PROCEDURES.** Operator maintenance is limited to performance of regular preventive maintenance checks and services and replenishment of cleaning solution.

## Section IV ORGANIZATIONAL MAINTENANCE

**6-11. LUBRICATION INSTRUCTIONS.** This equipment does not require lubrication.

**6-12. REPAIR PARTS, SPECIAL TOOLS; TEST, MEASUREMENT, AND DIAGNOSTIC EQUIPMENT (TMDE); AND SUPPORT EQUIPMENT**

6-12.1 Common Tools and Equipment. For authorized common tools and equipment, refer to the Modified Table of Organization and Equipment (MTOE) applicable to your unit.

6-12.2 Special Tools; Test, Measurement, and Diagnostic Equipment; and Support Equipment. Special Tools, TMDE, and Support Equipment is listed in the applicable repair parts and special tools list and in Appendix B of this manual.

6-12.3 Repair Parts. Repair parts are listed and illustrated in the Repair Parts and Special Tools List, TM 5-6675-322-24P covering organizational maintenance for this equipment.

**6-13. SERVICE UPON RECEIPT.**

6-13.1 Checking Unpacked Equipment.

a. Inspect the equipment for damage incurred during shipment. If equipment has been damaged, report the damage on DD Form 6, Packing Improvement Report.

b. Check the equipment against the packing list to see if the shipment is complete. Report all discrepancies in accordance with the instructions of DA Pam 738-750.

c. Check to see whether the equipment has been modified.

**6-14. ORGANIZATIONAL PREVENTIVE MAINTENANCE CHECKS AND SERVICES.** There are no organizational PMCS procedures assigned for this equipment.

**6-15. ORGANIZATIONAL TROUBLESHOOTING PROCEDURES.**

a. Organizational troubleshooting procedures cover the most common malfunctions that may be repaired at the organizational level. Repair or adjustment requiring specialized equipment is not authorized unless such equipment is available. Troubleshooting procedures used by the operator should be conducted in addition to the organizational troubleshooting procedures.

b. This manual cannot list all the possible malfunctions or every possible test/inspection and corrective action. If a malfunction is not listed or corrected by a listed corrective action, notify your supervisor.

c. For unidentified malfunctions, use the following schematic or the foldout located at the end of this manual for further fault analysis.

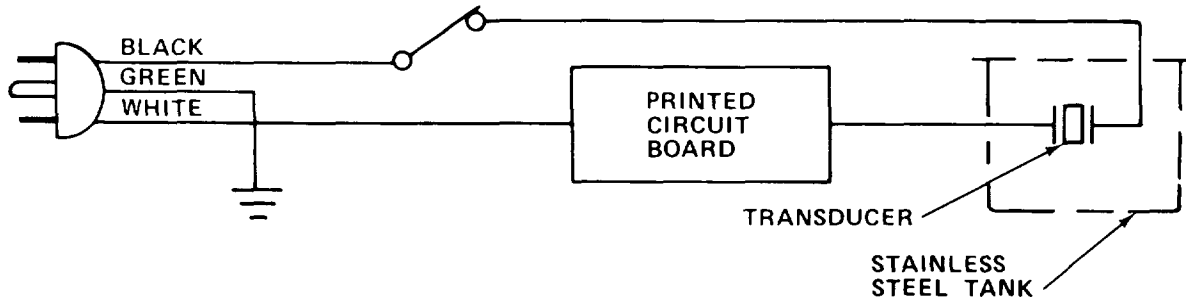

d. If the ultrasonic cleaner does not power up when turned on, verify that 120 V ac is present at the receptacle. If voltage is not present, plug equipment into receptacle with power available and proceed with equipment troubleshooting. Perform no-oier procedure for dead receptacle (Table 1-4).

**Table 6-2. ORGANIZATIONAL TROUBLESHOOTING**

MALFUNCTION	TEST OR INSPECTION	CORRECTIVE ACTION
1. NO CLEANING ACTION, WATER AGITATES.		<p>Check cleaning action using fresh cleaning solution.</p> <p>(a) If test was satisfactory, instruct operator to change cleaning solution when dirty.</p> <p>(b) If test was not satisfactory, replace circuit board (paragraph 6-16.3).</p>
2. NO WATER AGITATION.		<p>Step 1. Using multimeter, check for continuity of power cord.</p> <p>(a) If continuity exists, proceed to step 2.</p> <p>(b) If continuity does not exist, replace power cord (paragraph 6-16.1).</p>

**Table 6-2. ORGANIZATIONAL TROUBLESHOOTING - Cont**

---

MALFUNCTION
TEST OR INSPECTION
CORRECTIVE ACTION

---

2. NO WATER AGITATION - Cont

Step 2. Check continuity of power switch.

(a) If continuity does not exist, replace power switch (paragraph 6-16.2).

(b) If continuity does exist, replace circuit board (paragraph 6-16.3).

---

**6-16. MAINTENANCE PROCEDURES.**

a. This section contains instructions covering organizational maintenance functions for the ultrasonic cleaner. Personnel required are listed only if the task requires more than one.

b. After completing each maintenance procedure, perform operational check to be sure that equipment is properly functioning.

INDEX

PROCEDURE	PARAGRAPH
Replace Power Cord . . . . .	6-16.1
Replace Power Switch . . . . .	6-16.2
Replace Circuit Board . . . . .	6-16.3

6-16.1 Replace Power Cord.

MOS: 41B, Topographic Instrument Repair Specialist

TOOLS: Flat Tip Screwdriver

SUPPLIES: Power Cord  
Wire Clips

**WARNING**

Death or serious injury may occur if power cord is not unplugged before servicing.

- a. Turn power off. Unplug power cord.

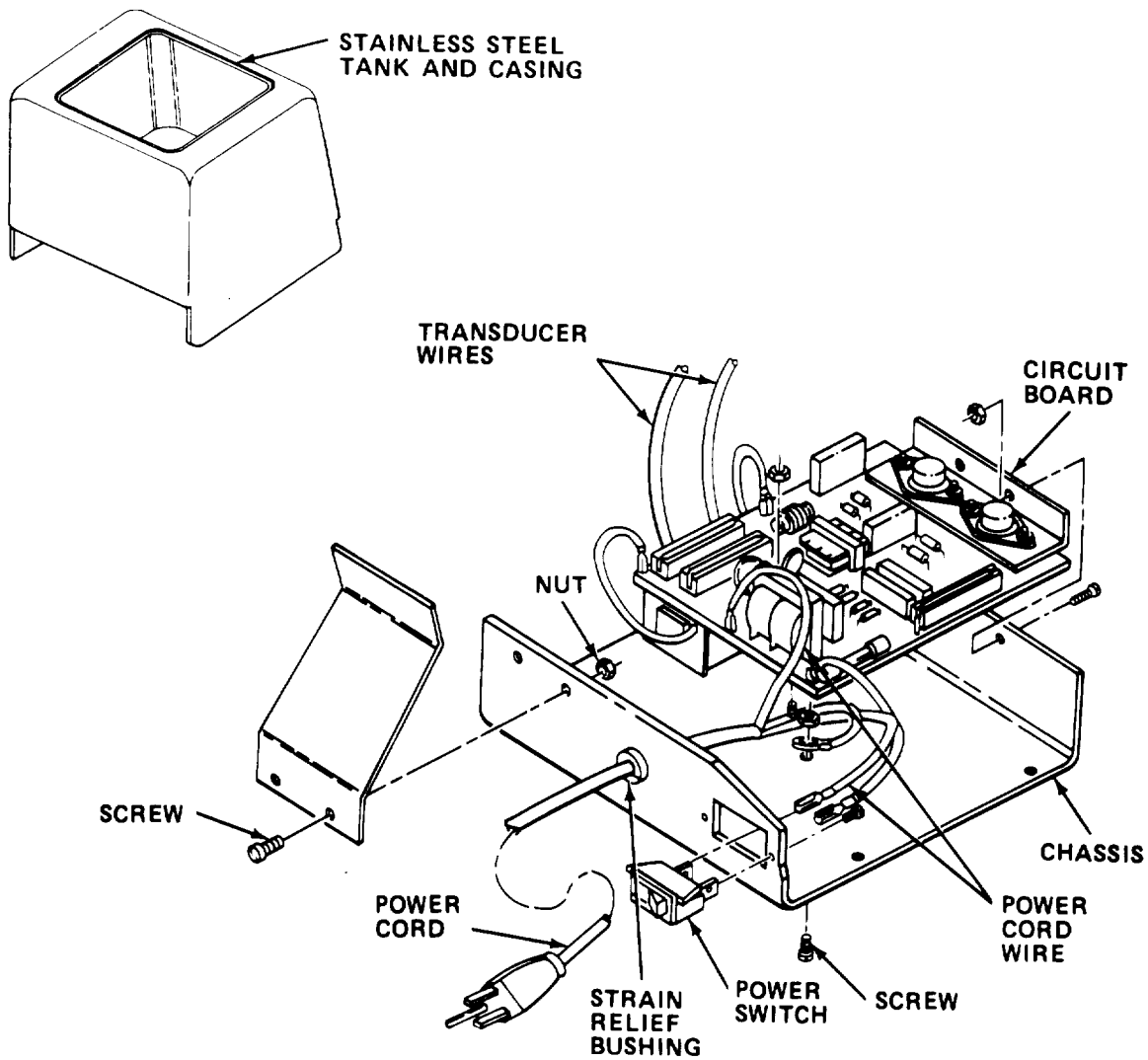



- b. Remove screws and washers holding stainless steel tank and casing to chassis.
- c. Lift stainless steel tank and casing free. Set aside.

**NOTE**

Do not disconnect wires to transducer.

- d. Remove three screws, one nut, and one washer holding circuit board to chassis.
- e. Disconnect power cord wire from power switch, chassis ground, and circuit board.
- f. Loosen strain relief bushing from chassis and remove defective power cord.
- g. Install strain relief bushing on new power cord. Insert terminal ends of cord into chassis.
- h. Fit strain relief bushing into chassis.
- i. Reconnect power cord wire to circuit board, chassis, and power switch.
- j. Reinstall circuit board into chassis and secure with one washer, one nut, and three screws.
- k. Reinstall stainless steel tank and casing. Secure with screws and washers.
- l. Fill stainless steel tank 1/3 full with water.
- m. Plug in power cord and turn power on. Check that water surface agitates.

6-16.2 Replace Power Switch.

MOS: 41B, Topographic Instrument Repair Specialist

TOOLS: Flat Tip Screwdriver

SUPPLIES: Switch

**WARNING**

Death or serious injury may occur from electrical shock unless power cord is unplugged before servicing.

- a. Turn power off and unplug power cord.

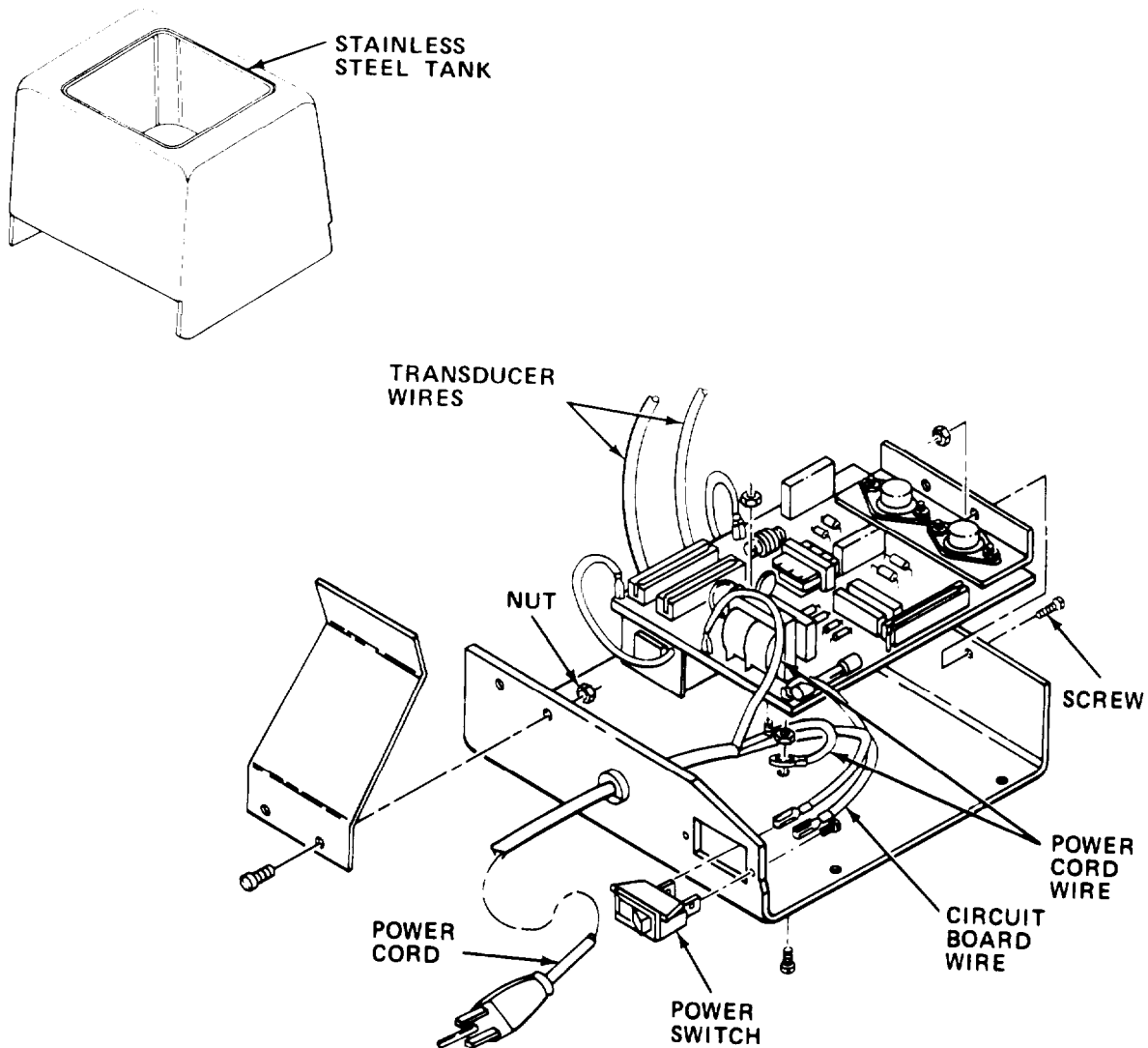

- b. Remove screws and washers holding stainless steel tank and casing to chassis.
- c. Lift stainless steel tank and casing free. Set aside.

**NOTE**

Do not disconnect wires to transducer.

- d. Tag and disconnect power cord wire from power switch.
- e. Press sides of defective power switch and remove from chassis.
- f. Install new power switch in chassis. Push power switch until tabs lock into hole.
- g. Reconnect power cord wires to power switch.
- h. Reinstall stainless steel tank and casing. Secure with screws and washers.
- i. Fill stainless steel tank 1/3 full with water.
- j. Plug in power cord and turn power on. Check that water surface agitates.

6-16.3 Replace Circuit Board.

MOS: 41B, Topographic Instrument Repair Specialist

TOOLS: Flat Tip Screwdriver

SUPPLIES: Circuit Board

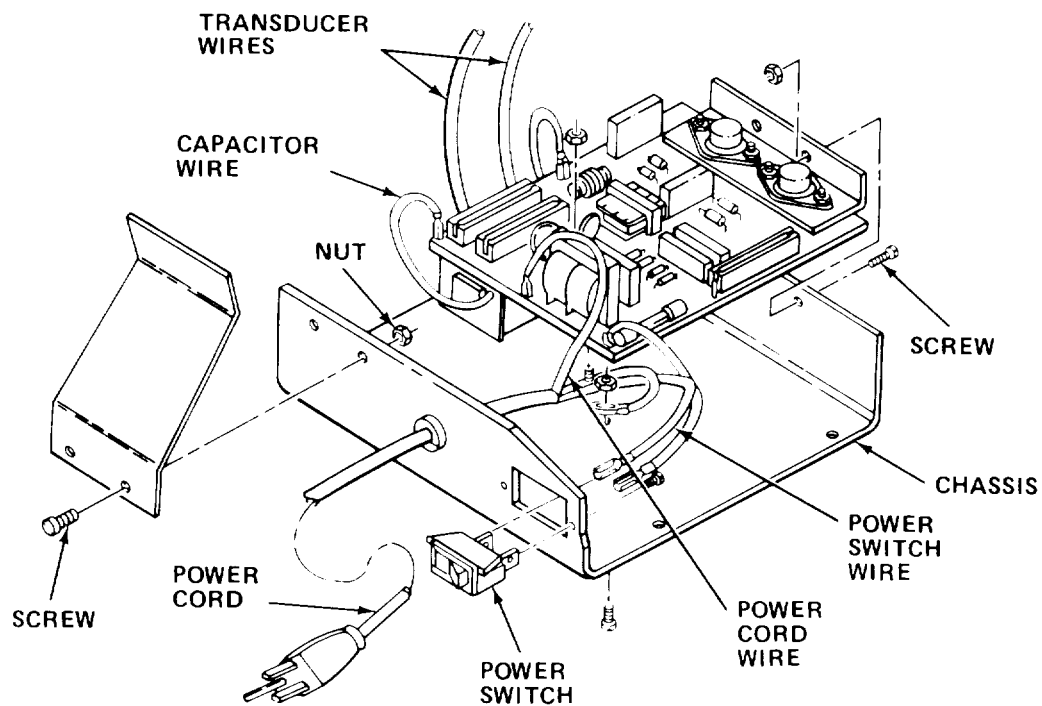

**WARNING**

Death or serious injury may occur from electrical shock unless power cord is unplugged before servicing.

- a. Turn power off and unplug power cord.
- b. Remove screws and washers holding stainless steel tank and casing to chassis.
- c. Lift stainless steel tank and casing free. Set aside.

**NOTE**

Do not disconnect wires to transducer.

- d. Remove three screws, one nut, and one washer holding circuit board to chassis.
- e. Tag and disconnect power cord wires and power switch wires from circuit board.
- f. Disconnect capacitor wires from circuit board.
- g. Tag and disconnect two transducer wires from circuit board.
- h. Remove defective circuit board.
- i. Install new circuit board.
- j. Reconnect two transducer wires to circuit board.
- k. Reconnect capacitor wires to circuit board.
- l. Reconnect power switch wires and power cord wires to circuit board.
- m. Reinstall one washer, one nut, and three screws holding circuit board to chassis.
- n. Reinstall stainless steel tank and casing. Secure with screws and washers.
- o. Fill stainless steel tank 1/3 full with water.
- p. Plug in power cord and turn power on. Check that water surface agitates.

**6-17. PREPARATION FOR STORAGE OR SHIPMENT.** Contact your battalion for packing and shipping instructions.

**Section V DIRECT/GENERAL SUPPORT MAINTENANCE**

There are no direct/general support maintenance procedures assigned for this equipment.





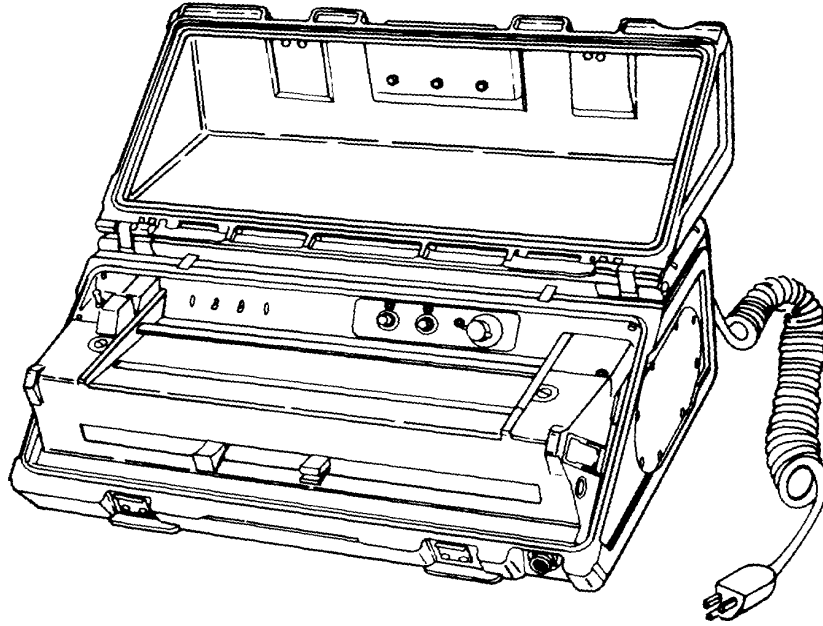



## CHAPTER 7

## FACSIMILE TRANSMISSION AND RECEIVING DEVICE

## Section I INTRODUCTION

## 7-1. GENERAL INFORMATION.

7-1.1 Scope.

a. Model Number and Equipment Name. Model AN/GXC-7A Facsimile Transmission and Receiving Device.

b. Purpose of Equipment. Used to transmit graphic material from one point to another by electrical means. Graphic material may consist of maps, photographs, line drawings, printed or typed material, or handwritten messages.

7-1.2 Reference Information.

TM-08104A-14/1, TM-11-5895-1079-14, Operator, Organizational, Direct Support, General Support, and Field Maintenance, Facsimile Transceiver AN/GXC-7A, contains the information applicable to this equipment.





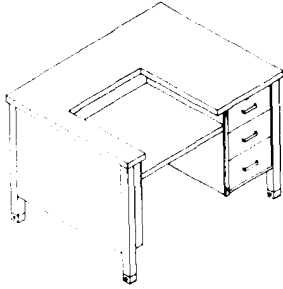

**TYPEWRITER DESK**

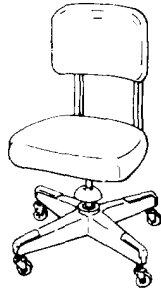

**ROTARY  
DRAFTING  
CHAIR**

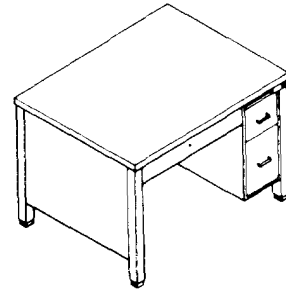

**FLAT TOP DESK**

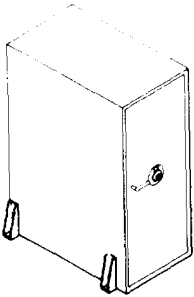

**MAP AND PLAN  
FILING CABINET**

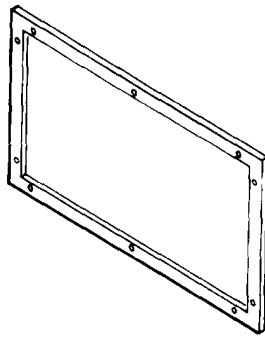

**CORKBOARD**

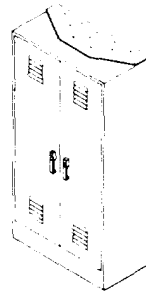

**SUPPLY  
CABINET**

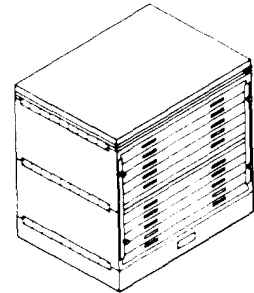

**MAP AND PLAN  
SECURITY CABINET**

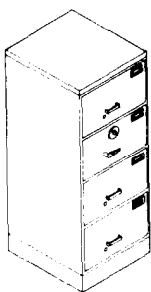

**SECURITY  
FILING  
CABINET**

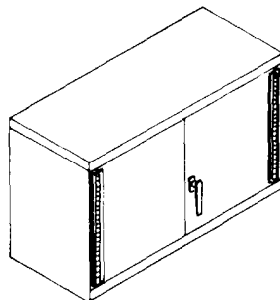

**WALL  
STORAGE  
CABINET**

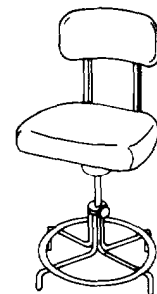

**ROTARY  
DESK CHAIR**

## CHAPTER 8

## FURNITURE AND CABINETS

## Section I INTRODUCTION

**8-1. GENERAL INFORMATION.**

8-1.1 Scope. This chapter contains the description of all Furniture and Cabinets contained in this section.

**8-2. EQUIPMENT DESCRIPTION.**

a. Typewriter desk. Provides a typing area and general work space for clerical personnel. The typewriter mounts to a recessed section of the desk top. There are three drawers and a pull-out writing table. The three drawers can be secured by a locking bar. Dimensions:

Width	45.0 in. (114.3 cm)
Depth	34.0 in. (86.4 cm)
Height	30.5 in. (77.5 cm)

b. Flat top desk. Provides work space for clerical personnel. It has three drawers and a pull-out writing table. The three drawers can be locked. Dimensions:

Width	45.0 in. (114.3 cm)
Depth	34.0 in. (86.4 cm)
Height	30.5 in. (77.5 cm)

c. Map and plan security cabinet. Used for the security storage of maps, plans and charts of various sizes. These items are hung from racks in the cabinet. The door is secured by a bolt work latch with an integral combination lock. Dimensions:

Width	22.0 in. (55.9 cm)
Depth	39.0 in. (99.1 cm)
Height	51.38 in. (130.51 cm)

d. Supply cabinet. Used for storage of miscellaneous large, bulky items. There are six shelves within the cabinet. It has two doors secured by a handle-type latch with a built-in lock. Dimensions:

Width	36.0 in. (91.4 cm)
Depth	28.0 in. (45.7 cm)
Height	64.5 in. (163.8 cm)

e. Map and plan filing cabinet. Used for flat, horizontal storage of maps, blueprints, charts and plans of various sizes. The ten drawers are held shut by two locking bars located on either side of the front of the cabinet. Dimensions:

Width	40.75 in. (103.51 cm)
Depth	28.62 in. (72.69 cm)
Height	41.68 in. (105.87 cm)

f. Security filing cabinet. Used for security storage of classified documents. It has four drawers locked by a latch and combination lock located on the second drawer. Dimensions:

Width	20.75 in. (52.71 cm)
Depth	28.0 in. (71.1 cm)
Height	52.0 in. (132.1 cm)

g. Wall storage cabinet. Used for miscellaneous storage. There are two shelves. The two doors are held shut by a handle-type latch on the right door. Dimensions:

Width	30.0 in. (76.2 cm)
Depth	12.0 in. (30.5 cm)
Height	18.0 in. (45.7 cm)

h. Rotary desk chair. Provides seating for personnel working at desk. It has a 3-3/4 in. (95.25 mm) seat height adjustment, ball bearing casters, tilt movement tension adjustment and adjustable back height. Dimensions:

Width	20.0 in. (50.8 cm)
Depth	21.0 in. (53.3 cm)
Height	32.0 in. (81.3 cm)

i. Rotary drafting chair. Provides seating for drafting personnel. It has adjustable seat height and back position. Dimensions:

Width	17.12 in. (43.48 cm)
Depth	17.12 in. (43.48 cm)
Height	42 in. (106.7 cm), Max 36 in. (91.4 cm), Min

j. Corkboard. Wall mounted. Dimensions:

Width	18.0 in. (45.7 cm)
Height	30.0 in. (76.2 cm)

**8-3. TECHNICAL PRINCIPLES OF OPERATION.** There are no specific principles of operation for this equipment.

## Section II OPERATING INSTRUCTIONS

**8-4. DESCRIPTION AND USE OF OPERATOR'S CONTROLS AND INDICATORS.** This equipment has no operator's controls or indicators.

**8-5. OPERATOR PREVENTIVE MAINTENANCE CHECKS AND SERVICES.** There are no operator PMCS procedures assigned for this equipment.

**8-6. OPERATION UNDER USUAL CONDITIONS.**

8-6.1 Preparation for Movement. Ensure that portable equipment is properly secured with tiedowns provided.

**8-7. OPERATION UNDER UNUSUAL CONDITIONS.** This equipment is designed for operation only in a controlled environment.

### Section III OPERATOR MAINTENANCE

**8-8. LUBRICATION INSTRUCTIONS.** This equipment does not require lubrication.

**8-9. TROUBLESHOOTING PROCEDURES.** There are no operator troubleshooting procedures assigned for this equipment.

**8-10. MAINTENANCE PROCEDURES.**

a. This section contains instructions covering operator maintenance functions for the furniture and cabinets. Personnel required are listed only if the task requires more than one.

b. After completing each maintenance procedure, perform operational check to be sure that equipment is properly functioning.

8-10.1 Inspect Furniture and Cabinets. Inspect furniture and cabinets for structural damage, rust, and proper operation of all latches, hinges, drawer slides, and adjustment mechanisms.

### Section IV ORGANIZATIONAL MAINTENANCE

**8-11. LUBRICATION INSTRUCTIONS.** This equipment does not require lubrication.

**8-12. REPAIR PARTS, SPECIAL TOOLS; TEST, MEASUREMENT, AND DIAGNOSTIC EQUIPMENT (TMDE); AND SUPPORT EQUIPMENT.**

8-12.1 Common Tools and Equipment. For authorized common tools and equipment, refer to the Modified Table of Organization and Equipment (MTOE) applicable to your unit.

8-12.2 Special Tools: Test, Measurement, and Diagnostic Equipment: and Support Equipment. Special Tools, TMDE, and Support Equipment is listed in the applicable repair parts and special tools list and in Appendix B of this manual.

8-12.3 Repair Parts. Repair parts are listed and illustrated in the Repair Parts and Special Tools List, TM 5-6675-322-24P covering organizational maintenance for this equipment.

**8-13. SERVICE UPON RECEIPT.**

8-13.1 Checking Unpacked Equipment.

a. Inspect the equipment for damage incurred during shipment. If the equipment has been damaged, report the damage on DD Form 6, Packing Improvement Report.



b. Check the equipment against the packing list to see if the shipment is complete. Report all discrepancies in accordance with the instructions of DA Pam 738-750.

c. Check to see whether the equipment has been modified.

**8-14. ORGANIZATIONAL PREVENTIVE MAINTENANCE CHECKS AND SERVICES.** There are no organizational PMCS procedures assigned for this equipment.

**8-15. ORGANIZATIONAL TROUBLESHOOTING PROCEDURES.** There are no organizational troubleshooting procedures assigned for this equipment.

**8-16. MAINTENANCE PROCEDURES.**

a. This section contains instructions covering organizational maintenance functions for the furniture and cabinets. Personnel required are listed only if the task requires more than one.

b. After completing each maintenance procedure, perform operational check to be sure that equipment is properly functioning.

INDEX

PROCEDURE	PARAGRAPH
Replace Door Latch (Wall Storage Cabinet) . . . . .	8-16.1
Replace Door Hinge (Piano Hinge) . . . . .	8-16.2
Remove/Install Map and Plan Filing Cabinet/Portable Drawing Board Assembly . . . . .	8-16.3
Remove/Install Wall Storage Cabinet . . . . .	8-16.4
Remove/Install Supply Cabinet . . . . .	8-16.5
Remove/Install Map and Plan Security Cabinet . . . . .	8-16.6
Remove/Install Typewriter Desk . . . . .	8-16.7
Remove/Install Security Filing Cabinet . . . . .	8-16.8
Remove/Install Flat Top Desk . . . . .	8-16.9
Remove/Install Corkboard . . . . .	8-16.10

8-16.1 Replace Door Latch (Wall Storage Cabinet).

MOS: 83FJ6, Reproduction Equipment Repairer

TOOLS: 9/16 in. Combination Wrench  
Flat Tip Screwdriver

SUPPLIES: Handle Type Latch

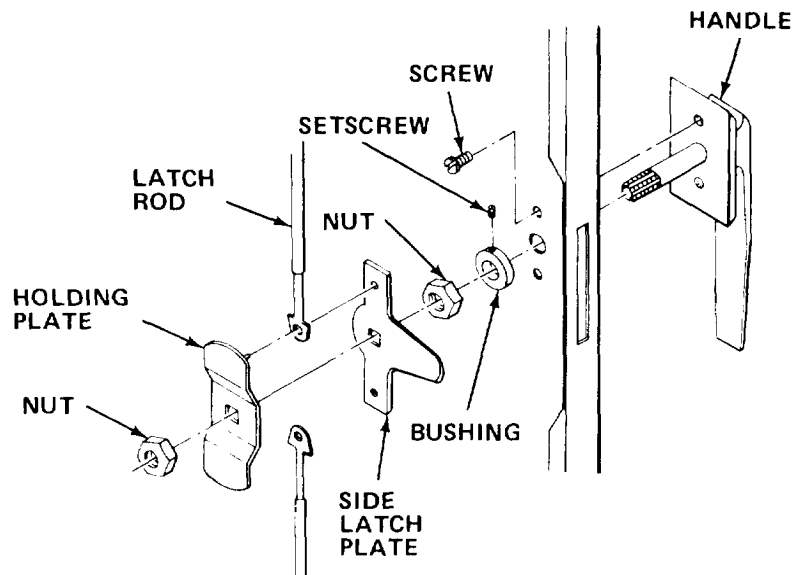

- a. Remove holding plate retaining nut.
- b. Remove holding plate and latch rods.
- c. Remove side latch plate.
- d. Remove handle retaining nut.
- e. Loosen setscrew and remove bushing from handle shaft.
- f. Remove two handle retaining screws and remove handle.
- g. Install new handle and secure with two screws.
- h. Reinstall bushing on handle shaft and tighten setscrew.
- i. Reinstall handle retaining nut.
- j. Reinstall side latch plate.
- k. Reinstall latch rod holding plate and latch rods.
- l. Reinstall holding plate retaining nut.

8-16.2 Replace Door Hinge (Piano Hinge).

MOS: 83FJ6, Reproduction Equipment Repairer

TOOLS: 1/4 in. Electric Drill  
5/32 in. Drill Bit  
Pop Rivet Gun

SUPPLIES: Piano Hinge  
5/32 in. Pop Rivets  
8-32 x 1/2 in. Screws (4 required)  
8-32 Nuts (4 required)

- a. Drill out rivets holding hinge to cabinet and remove hinge.
- b. Install new hinge and temporarily secure with four screws and nuts.
- c. Close and latch cabinet door and install pop rivets
- d. Remove temporarily installed screws and nuts, and install remaining pop rivets.

8-16.3 Remove/Install Map and Plan Filing Cabinet/Portable Drawing Board Assembly.

MOS: 83FJ6, Reproduction Equipment Repairer

PERSONNEL: Two persons are required to perform this procedure.

TOOLS: Rivet Gun  
Drill and Bits  
Flat Tip Screwdriver

SUPPLIES: Portable Drawing Board  
Map and Plan Filing Cabinet  
Rivets

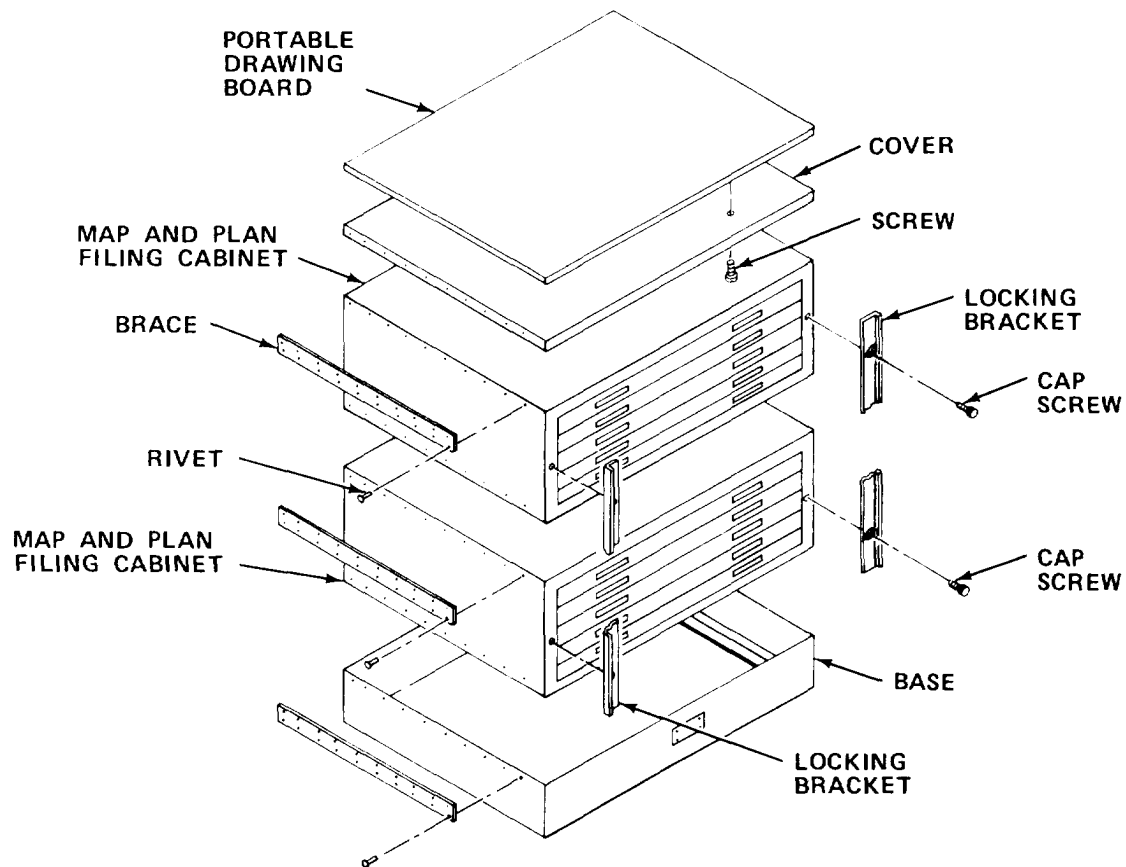

- a. Drill rivets from braces and remove braces.
- b. Remove map and plan filing cabinet cover, turn cover over, remove screws and portable drawing board from cover. Retain screws for reuse.
- c. Remove knurled screws from locking bracket on each side of front. Then remove locking bracket.

**WARNING**

Serious personal injury can result if an inadequate number of personnel are used to move the map and plan filing cabinet.

- d. Lift top and bottom sections free from base.
- e. Remove screws and base from floor. Retain screws for reuse.
- f. Install new base, top or bottom, map and plan filing cabinet, or drawing board as required.
- g. Reinstall base to floor and secure with screws.
- h. Reinstall bottom section to base and rivet braces to base and bottom sections.
- i. Reinstall top section on bottom section and rivet braces to both top and bottom sections.
- j. Reinstall portable drawing board on cover and secure with screws.
- k. Reinstall cover on top section and rivet braces to both the cover and top section.
- l. Reinstall locking brackets, and secure with knurled screws.

8-16.4 Remove/Install Wall Storage Cabinet.

MOS: 83FJ6, Reproduction Equipment Repairer

TOOLS: 1/2 in. Socket, 1/2 in. Drive  
1/2 in. Drive Ratchet  
1/2 in. Socket Extension, 2 in. Long

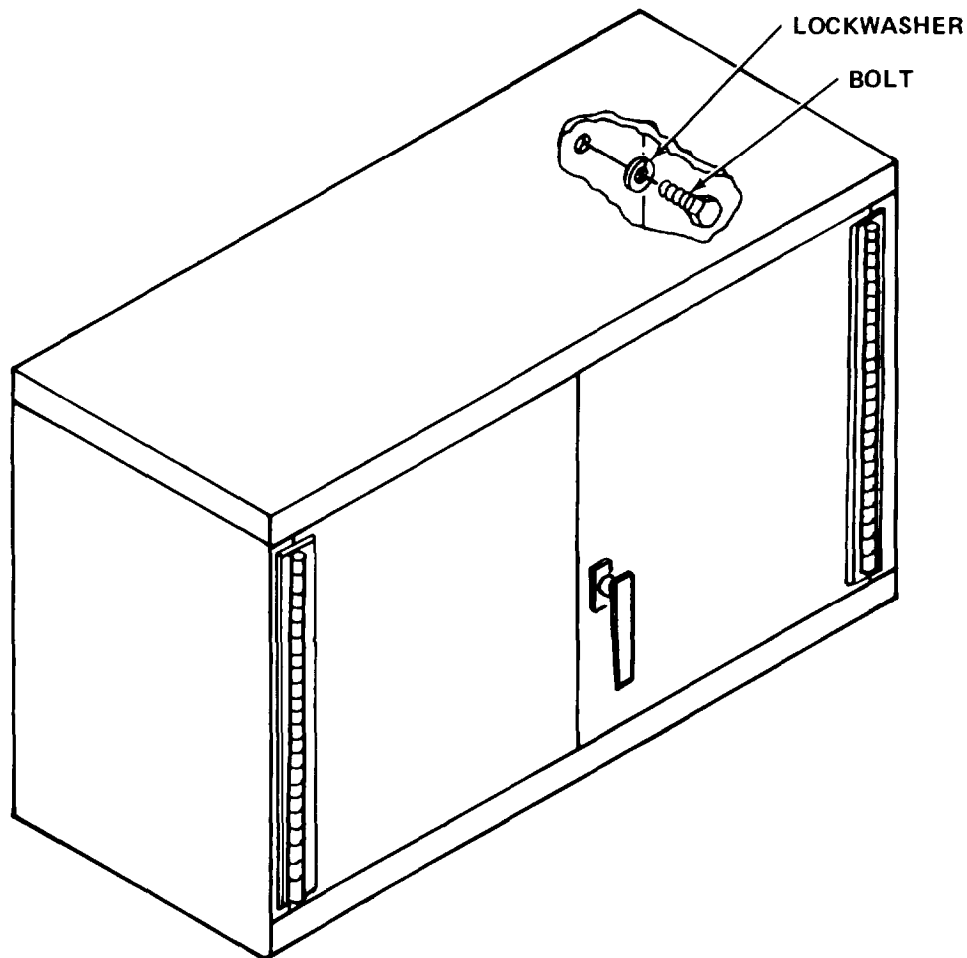

- a. Remove fluorescent light fixture from underneath cabinet if applicable.
- b. Remove bolts and lockwashers which secure defective cabinet to wall.
- c. Remove defective cabinet.
- d. Install new cabinet and secure to wall with lockwashers and bolts.

8-16.5 Remove/Install Supply Cabinet.

MOS: 83FJ6, Reproduction Equipment Repairer

TOOLS: 1/4 in. Socket Set  
 1/4 in. Socket Extension, 6 in. Long  
 11/32 in. Combination Wrench  
 Cross Tip Screwdriver

SUPPLIES: Supply Cabinet

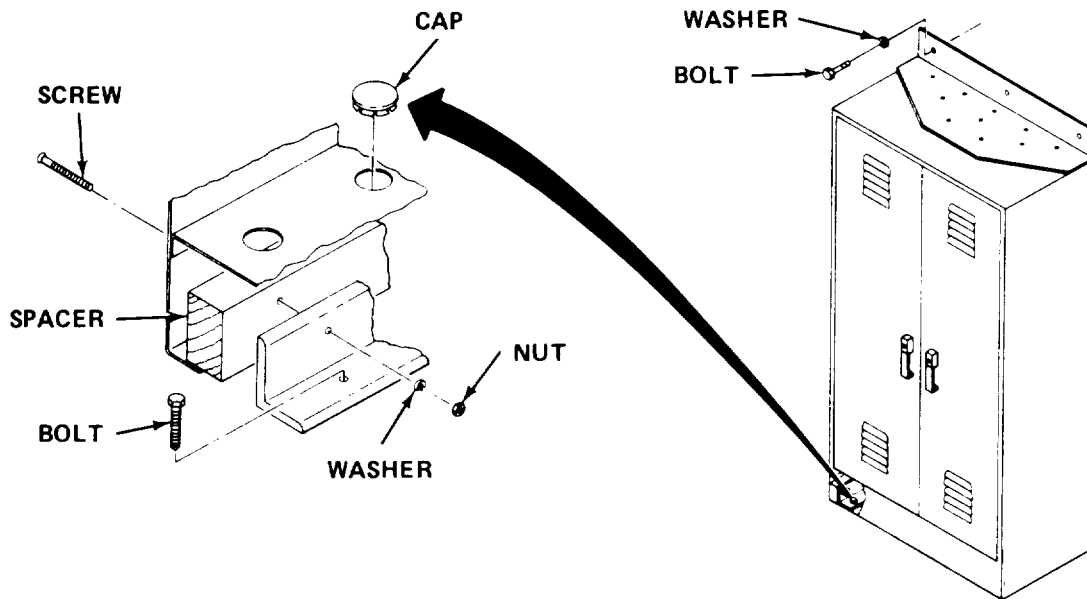

- a. Remove bolts and washers holding cabinet to wall.
- b. Remove caps and lag bolts holding mounting bracket to floor and remove cabinet.
- c. Remove screws, lockwashers, and nuts and remove mounting bracket and spacer from cabinet. Retain mounting bracket and spacers for use on new cabinet.
- d. Position spacers and mounting bracket on new cabinet, and install but do not tighten screws, lockwashers, and nuts.
- e. Place new cabinet in position, and install but do not tighten lag bolts.
- f. Secure cabinet to wall with flat washers and bolts.
- g. Tighten the bracket retaining bolts and nuts.
- h. Tighten the bolts holding the mounting bracket to the floor, and install the caps.

8-16.6 Remove/Install Map and Plan Security Cabinet.

MOS: 83FJ6, Reproduction Equipment Repairer

PERSONNEL: Two persons are required to perform this procedure.

TOOLS: 1/2 in. Drive Ratchet  
1-1/8 in. Socket, 1/2 in. Drive  
3 in. Extension

SUPPLIES: Map and Plan Security Cabinet

- a. Open map and plan security cabinet and move materials to secure storage.
- b. Tape lock combination to outside of cabinet.

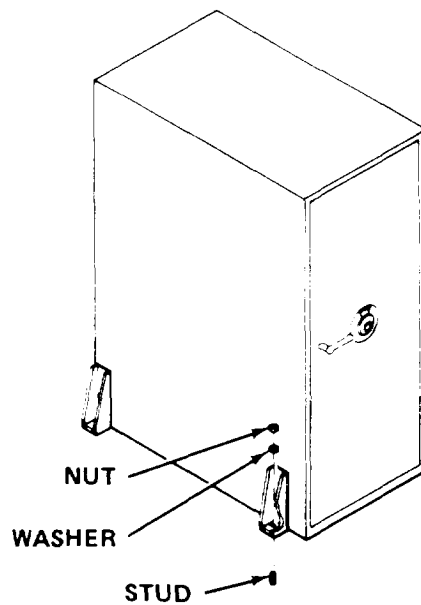



- c. Remove nut and washer from floor mounting studs.
- d. Raise cabinet onto skids and move to cargo door.

**WARNING**

Severe personal injury may occur when loading the cabinet to or from van due to cabinet's weight. Use special care and use only approved lifting equipment.

- e. Remove cabinet from section.
- f. Bring new cabinet into section.
- g. Locate cabinet over studs and reinstall nuts and washers.
- h. Have lock combination changed on cabinet before replacing material in cabinet.

8-16.7 Remove/Install Typewriter Desk.

MOS: 83FJ6, Reproduction Equipment Repairer

TOOLS: 1/4 in. Drive Ratchet  
1/2 in. Drive Socket, 1/4 in. Drive  
3 in. Extension, 1/4 in. Drive

SUPPLIES: Typewriter Desk

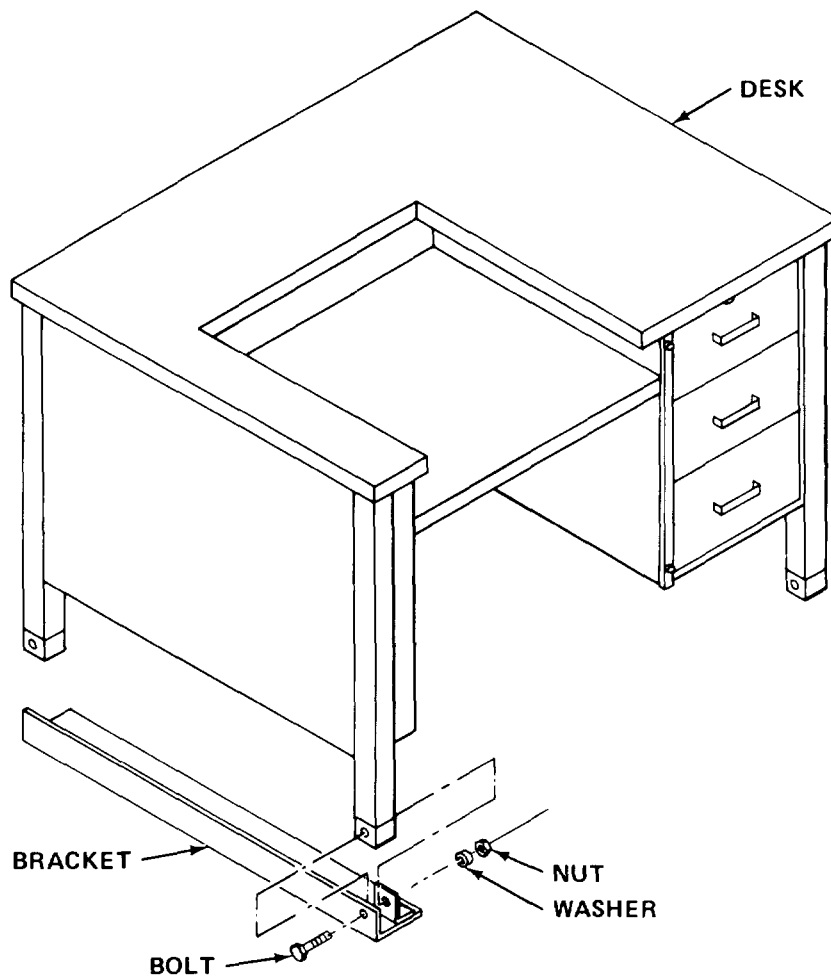

- a. Remove typewriter (paragraph 9-16.2).
- b. Remove mounting bolts, washers, and nuts.
- c. Remove desk.
- d. Position new desk and line up holes with mounting bracket.
- e. Secure with bolts, washers, and nuts.

8-16.8 Remove/Install Security Filing Cabinet.

MOS: 83FJ6, Reproduction Equipment Repairer

PERSONNEL: Two persons are required to perform this procedure.

TOOLS: 1/2 in. Drive Ratchet  
1-1/8 in. Socket, 1/2 in. Drive  
3 in. Extension

SUPPLIES: Security Filing Cabinet

- a. Open cabinet.
- b. Remove contents and temporarily store in secure area.
- c. Tape lock combination to outside of cabinet.
- d. Remove nuts and washers.

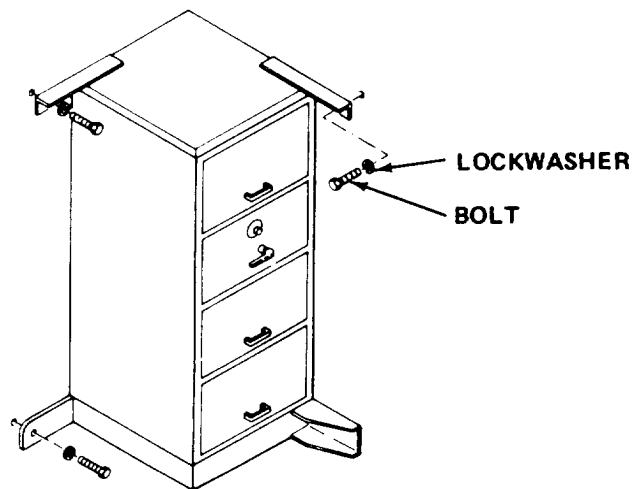

**WARNING**

Serious injury may result if security filing cabinet is removed or replaced in the section without using adequate lifting equipment.

- e. Move cabinet to door.
- f. Remove cabinet from section.
- g. Position new cabinet over studs and reinstall washers and nuts.
- h. Have combination lock changed to new combination before storing material in security filing cabinet.

8-16.9 Remove/Install Flat Top Desk.

MOS: 83FJ6, Reproduction Equipment Repairer

TOOLS: 1/4 in. Drive Ratchet  
1/2 in. Socket, 1/4 in. Drive  
3 in. Extension, 1/4 in. Drive

SUPPLIES: Flat Top Desk

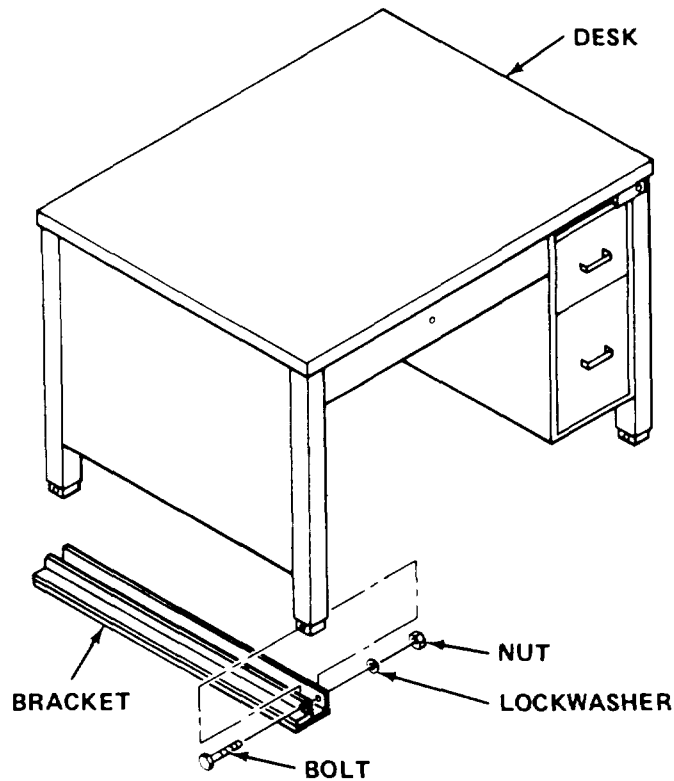

- a. Remove material from drawers. Lock drawers and tape key to desk.
- b. Remove mounting bolts, washers, and nuts.
- c. Remove desk.
- d. Position new desk and line up holes with mounting bracket.
- e. Secure with bolts, washers, and nuts.

8-16.10 Remove/Install Corkboard.

MOS: 83FJ6, Reproduction Equipment Repairer

TOOLS: Cross Tip Screwdriver

SUPPLIES: Corkboard

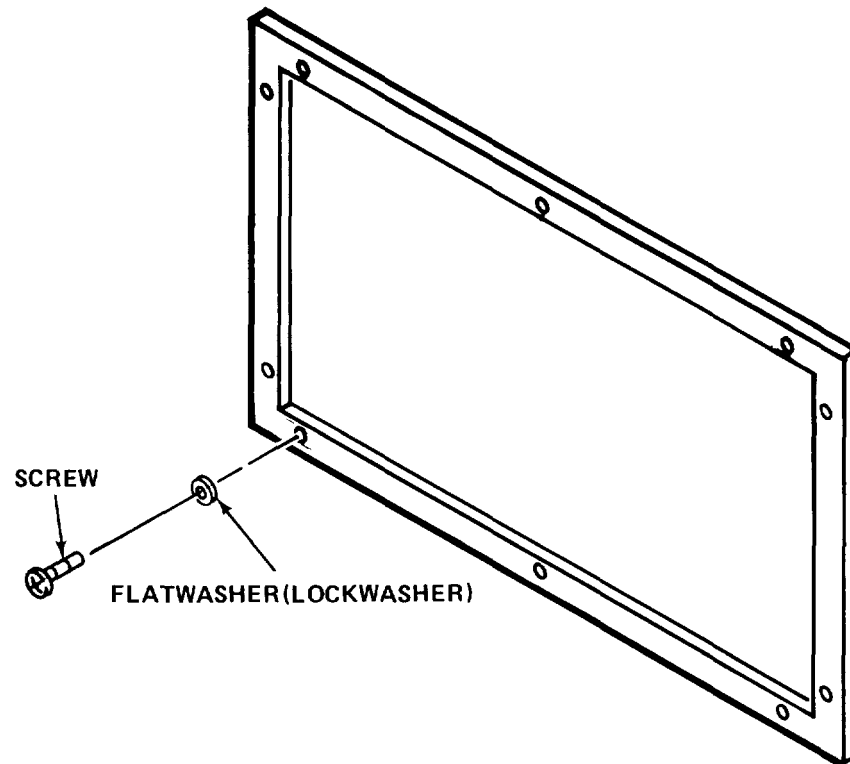

- a. Remove attaching hardware securing defective corkboard to wall.
- b. Remove defective corkboard.
- c. Position new corkboard and align mounting holes.
- d. Secure new corkboard to wall with attaching hardware.

**8-17. PREPARATION FOR STORAGE OR SHIPMENT.** Contact your battalion for packing and shipping instructions.

### Section V DIRECT/GENERAL SUPPORT MAINTENANCE

There are no direct/general support maintenance procedures assigned for this equipment.





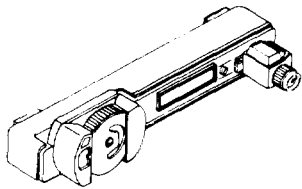

**OPTICAL RANGE FINDER**

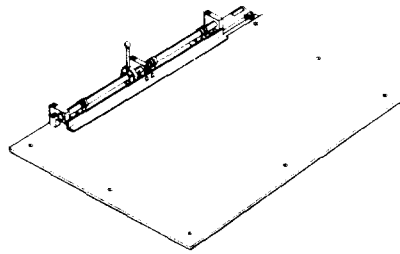

**PIN PUNCH REGISTER**

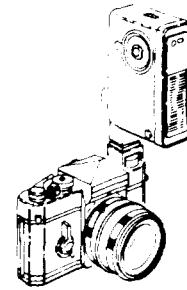

**STILL PICTURE CAMERA SET**

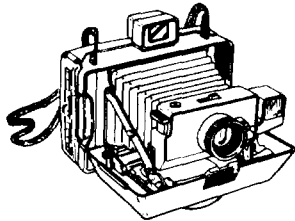

**STILL PICTURE (INSTANT) CAMERA SET**



**PRECIPITATION GAGE**

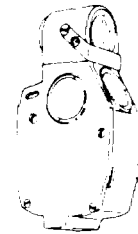

**OPTICAL TREE MEASURER**

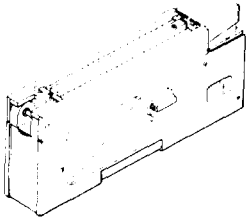

**HAND PSYCHROMETER**

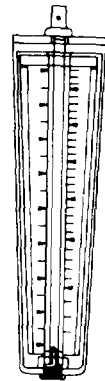

**AIR VELOCITY METER**

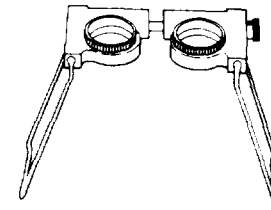

**POCKET STEREOSCOPE**

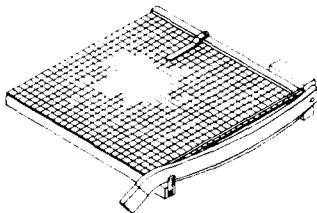

**PAPER TRIMMER**

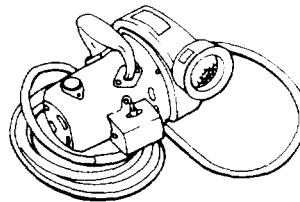

**VACUUM CLEANER**

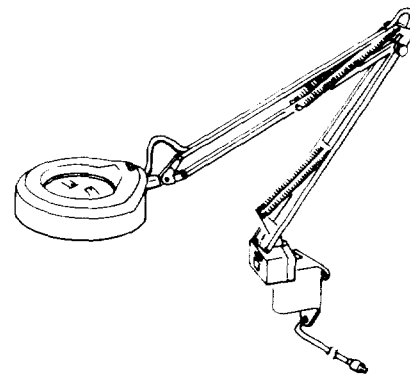

**MAGNIFIER LAMP**

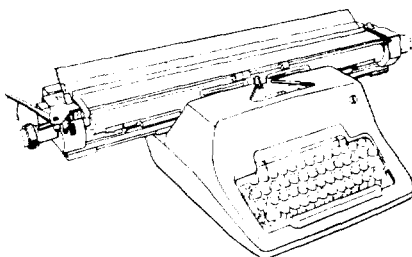

**MANUAL TYPEWRITER**



## CHAPTER 9

### SUPPORT ITEMS

#### Section I INTRODUCTION

##### 9-1. GENERAL INFORMATION .

9-1.1 Scope. This chapter covers the support items contained in this section. The support items consist of the following equipment:

- a. Model LFM1BX5 Magnifier Lamp.
- b. Model 3400 Vacuum Cleaner.
- c. Type 1 Pocket 2X Stereoscope.
- d. Special Model Pin Punch Register.
- e. Model Fed-99-T-678 Paper Trimmer.
- f. Model SG3B Manual Typewriter.
- g. Model 566-3 Hand Psychrometer.
- h. Model 5100,054 Air Velocity Meter.
- i. Model 1200 Optical Range Finder.
- j. Optical Tree Measurer.
- k. EE-100 Still Picture (Instant) Camera Set.
- l. Model KS99 Still Picture Camera.
- m. Model 5100-451 Precipitation Gage.

##### 9-2. EQUIPMENT DESCRIPTION.

###### 9-2.1 Equipment Characteristics, Capabilities, and Features.

- a. Magnifier lamp. Adjustable for accurate positioning to provide illuminated magnification of precision work. Provision for both wall and bench mounting.
- b. Vacuum cleaner. High speed, heavy duty, used for general cleaning.
- c. Pocket stereoscope. Optically matches and gives operator an apparent single image of two maps or photographs.
- d. Pin Punch register. Heavy duty hole punch that provides operator with a large flat surface for punching holes in paper maps and charts of different sizes.

- e. Paper trimmer. Cuts paper up to 24 in. wide.
- f. Manual typewriter. Refer to operator's manual supplied with the typewriter for characteristics, capabilities, and features.
- g. Hand psychrometer. Uses battery powered fan to provide air flow across wet and dry bulb thermometers to determine relative humidity.
- h. Air velocity meter. Used to indicate wind speeds from 2 to 66 mph.
- i. Optical range finder. Used to determine range of various objects. Calibrated in meters.
- j. Optical tree measurer. Measures basal tree area, diameter and height. Vertical angles are measured in percent. Distance measurements are in meters.
- k. EE-100 Still picture (instant) camera set. Refer to operator's manual supplied with camera for characteristics, capabilities, and features
- l. Model KS99 still picture camera set. Refer to operator's manual supplied with camera for characteristics, capabilities, and features.
- m. Precipitation gage. Uses graduated measuring stick for scale measurement of rainfall.

#### 9-2.2 Equipment Data.

- a. Magnifier lamp. Replaceable 120 V ac lamp and diffuser.
- b. Vacuum cleaner. Packed in storage box containing hose, various vacuum and blowing attachments, liquid spray attachments, and motor repair kit containing motor bearings and brushes.
- c. Hand psychrometer. Packed in carrying case containing a 1 oz (30 ml) water bottle, psychrometer chart, instruction booklet, and slide rule.
- d. Manual typewriter. Refer to operator's manual supplied with the typewriter for equipment data.

**9-3. TECHNICAL PRINCIPLES OF OPERATION.** Principles of operation are combined with operator's controls and indicators.

Section II OPERATING INSTRUCTIONS

9-4. DESCRIPTION AND USE OF OPERATOR'S CONTROLS AND INDICATORS.

9-4.1 Magnifier Lamp.

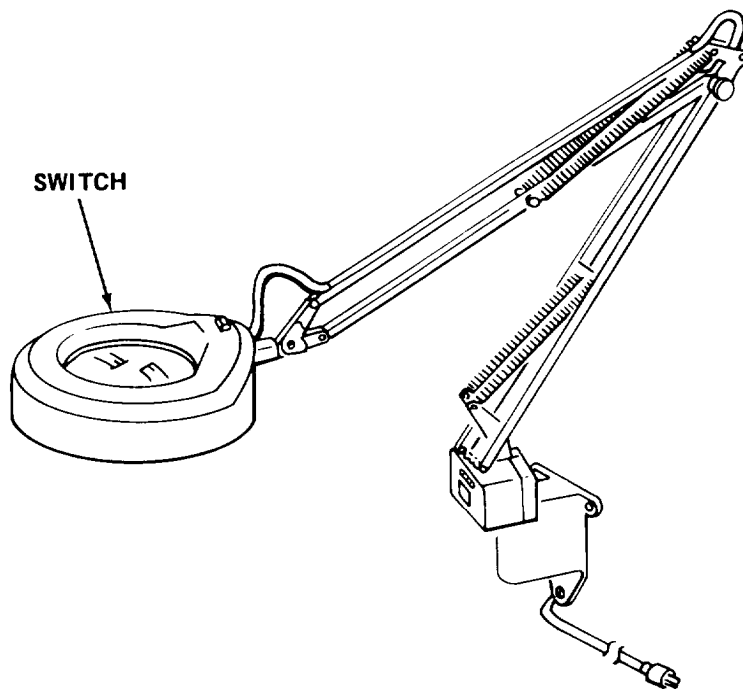

Control or Indicator	Function
Switch	Turns lamp on/off.

9-4.2 Vacuum Cleaner.

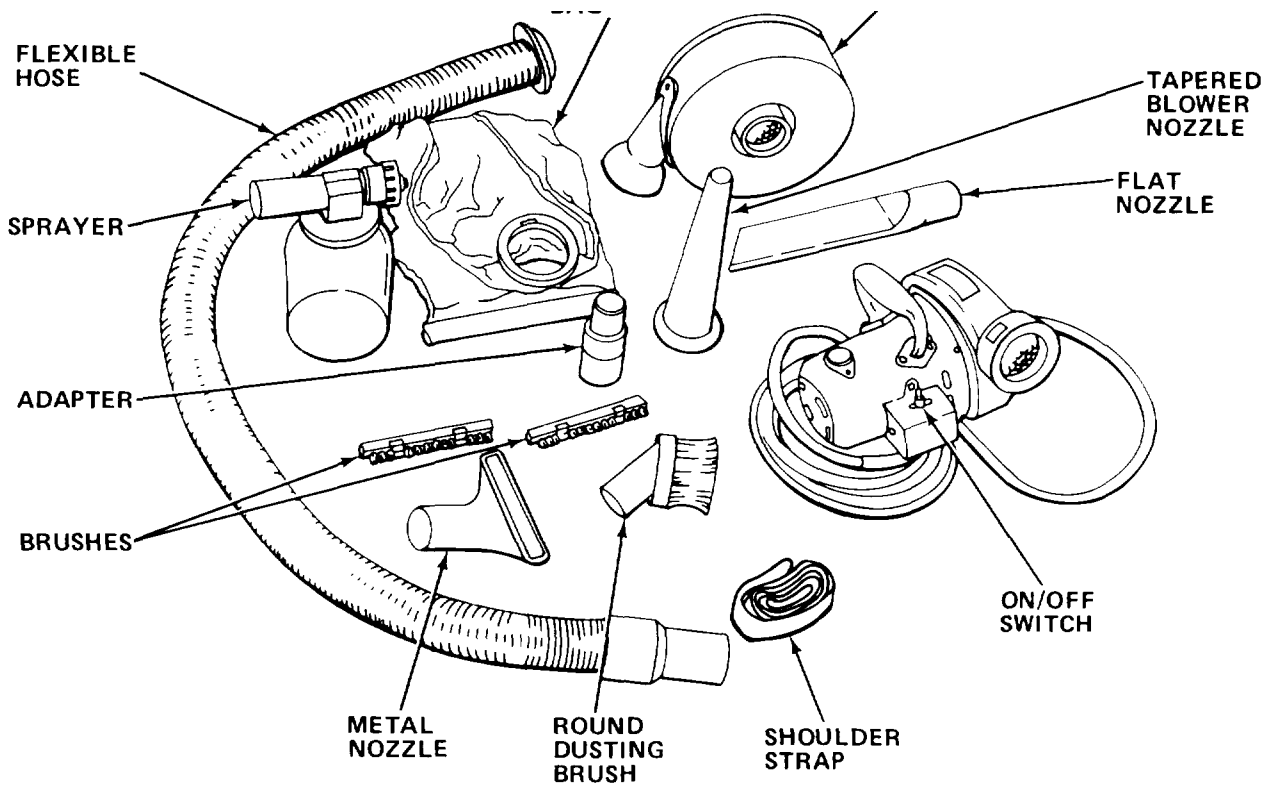

Control or Indicator	Function
Sprayer	Sprays liquids when hooked to blower side of vacuum cleaner.
Flexible Hose	Directs airflow in hard-to-reach areas.
Dust Collection Bag	Collects and holds dust and dirt.
Scrap Trap	Traps large particles before they enter fan.
Tapered Blower Nozzle	Directs airflow.
Flat Nozzle	Used for hard-to-reach areas.
ON/OFF Switch	Turns power on or off.

Control or Indicator	Function
Shoulder Strap	Attaches to vacuum cleaner for easier carrying.
Round Dusting Brush	Used for light dust and dirt.
Metal Nozzle	Used for large, flat surfaces.
Brushes	Used on metal nozzle.
Adapter	Connects various attachments to hose.

9-4.3 Pocket Stereoscope.

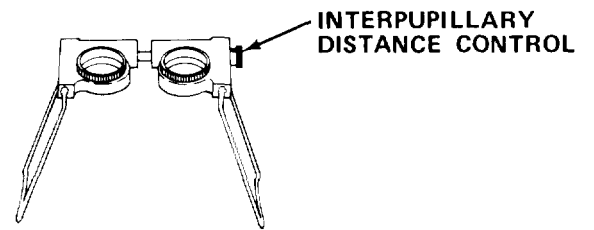

Control or Indicator	Function
Interpupillary Distance Control	Adjusts interpupillary distance of lenses to match that of viewer.

9-4.4 Pin Punch Register.

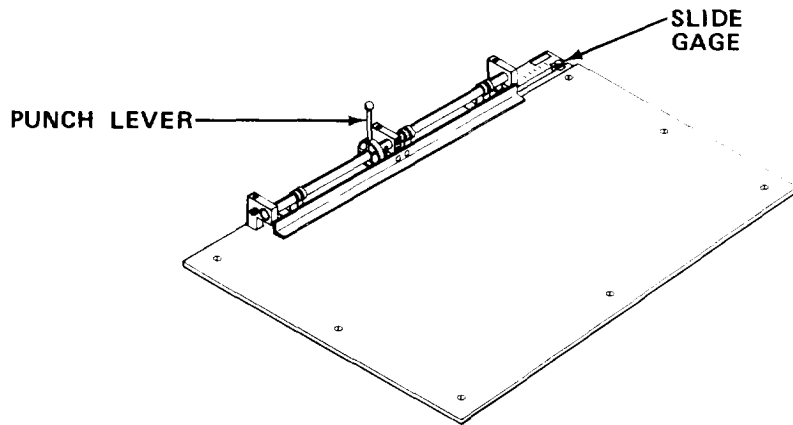

Control or Indicator	Function
Punch Lever	Operates eccentric which presses down on punch pin and forces it through material.
Slide Gage	Positions material for proper positioning of punch holes.

9-4.5 Paper Trimmer.

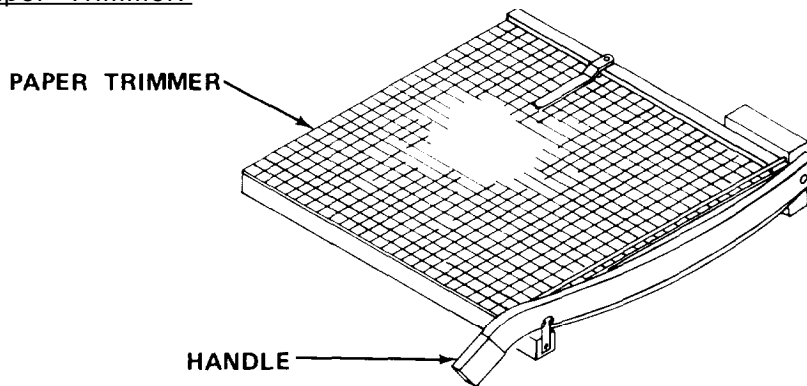

Control or Indicator	Function
Handle	Operates cutter.

9-4.6 Manual Typewriter. Refer to operator's manual supplied with the typewriter for the controls and indicators not shown.

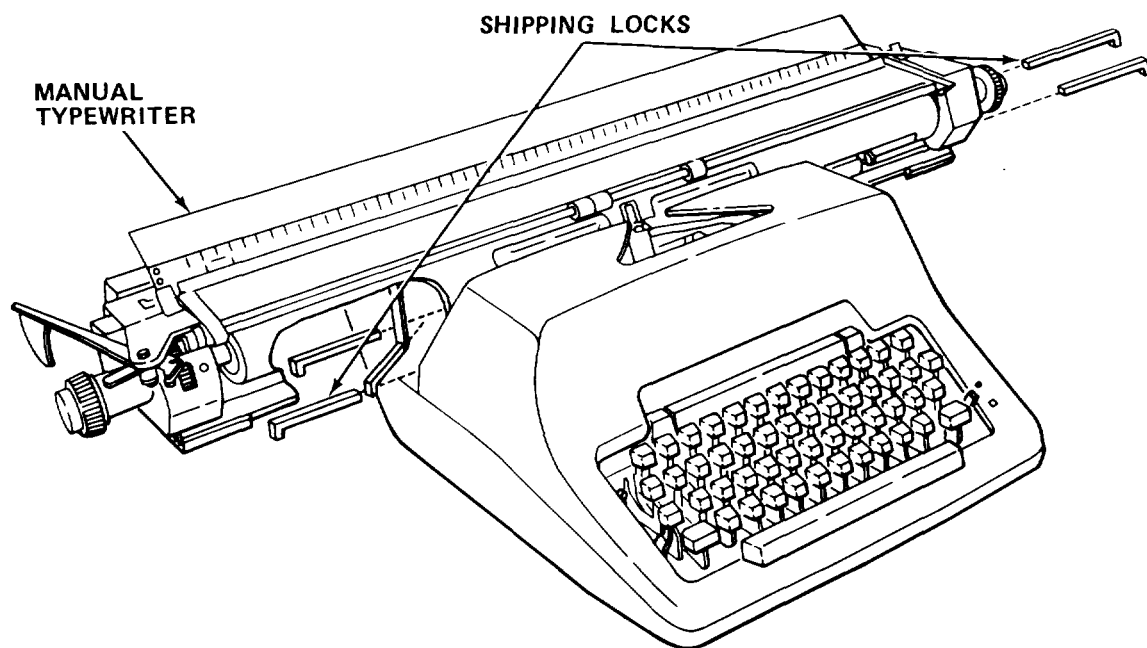

Control or Indicator	Function
Shipping Lock	Locks carriage when typewriter is being transported.

9-4.7 Hand Psychrometer.

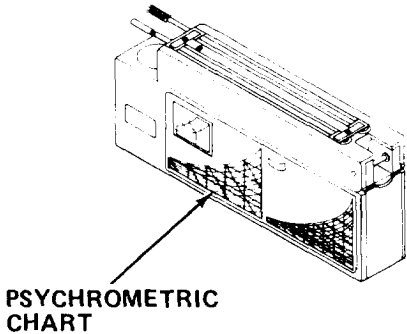
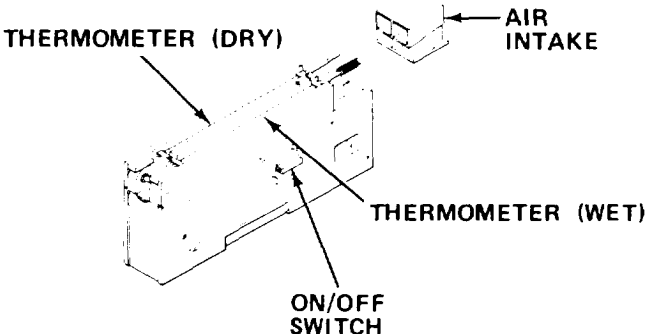
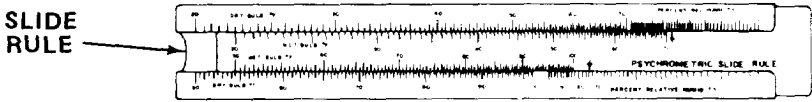
Control or Indicator	Function
 <p>PSYCHROMETRIC CHART</p>	 <p>THERMOMETER (DRY)</p> <p>AIR INTAKE</p> <p>THERMOMETER (WET)</p> <p>ON/OFF SWITCH</p>
 <p>SLIDE RULE</p>	
Air Intake	Directs air flow over wet and dry bulbs.
Thermometer (Dry)	Indicates dry bulb temperature in degrees Fahrenheit.
Thermometer (Wet)	Indicates wet bulb temperature in degrees Fahrenheit.
ON/OFF Switch	Turns on fan motor and, when turned fully right, provides thermometer illumination.
Psychrometric Chart	Utilizes wet and dry bulb temperatures to determine relative humidity.
Slide Rule	Used to determine relative humidity. After taking thermometer readings, align wet and dry bulb readings.



9-4.8 Air Velocity Meter.

Control or Indicator	Function
Low Speed Scale	Indicates wind speed from 2-10 mph.
Low and High Range Orifice	Determines which scale is to be observed for reading.
Calibration Orifice	Allows accurate calibration of reading.
High Speed Scale	Indicates wind speed from 4-66 mph when orifice is covered.
Indicating Pith Ball	Indicates wind speed to be determined from scale.
Cleaning Access Screws	Allows access for cleaning.
Air Inlet Holes	Located on opposite face to scale. Provides venturi effect to raise pith ball in relation to wind speed.

9-4.9 Optical Range Finder.

---

Control or Indicator	Function
----------------------	----------

---

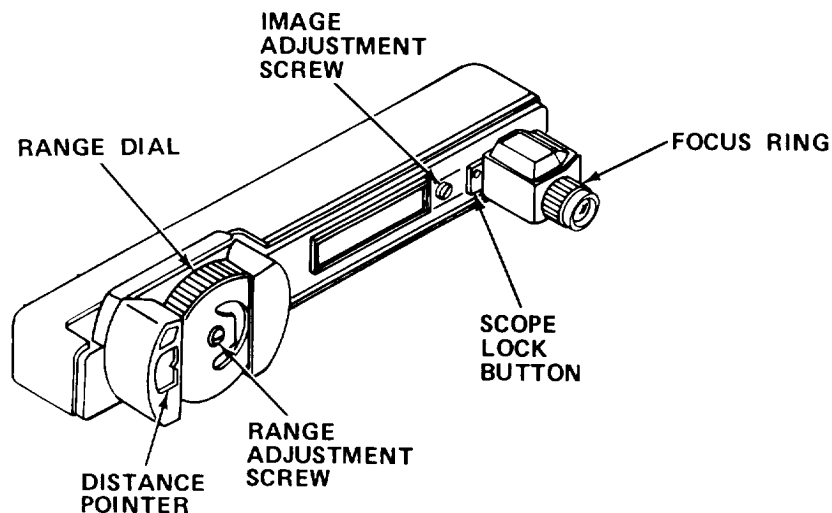

Range Dial	Moves yellow and blue images toward or away from each other.
Focus Ring	Focuses telescopic, monocular eyepiece.
Scope Lock Button	Locks telescopic, monocular eyepiece to range finder.
Image Adjustment Screw	Adjusts image vertically.
Range Adjustment Screw	Adjusts range dial.
Distance Pointer	Indicates distance in meters.

---

9-4.10 Optical Tree Measurer.

---

Control or Indicator	Function
----------------------	----------

---

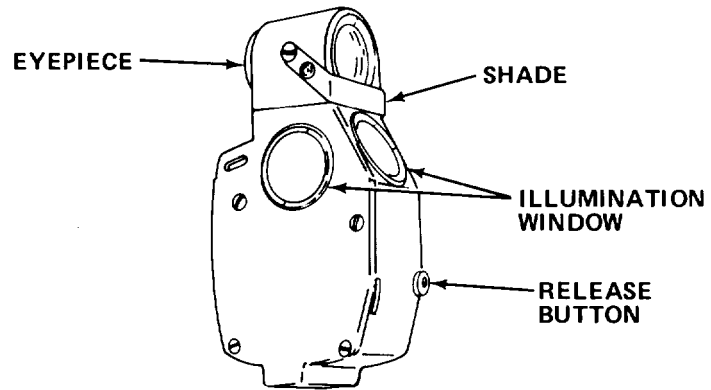

Eyepiece

Aligns operator's eye.

Shade

Shades line of sight from sun.

Illumination Window

Permits illumination of scales.

Release Button

Releases pendulum lock.

---

9-4.11 Still Picture (Instant) Camera Set.

Control or Indicator	Function
----------------------	----------

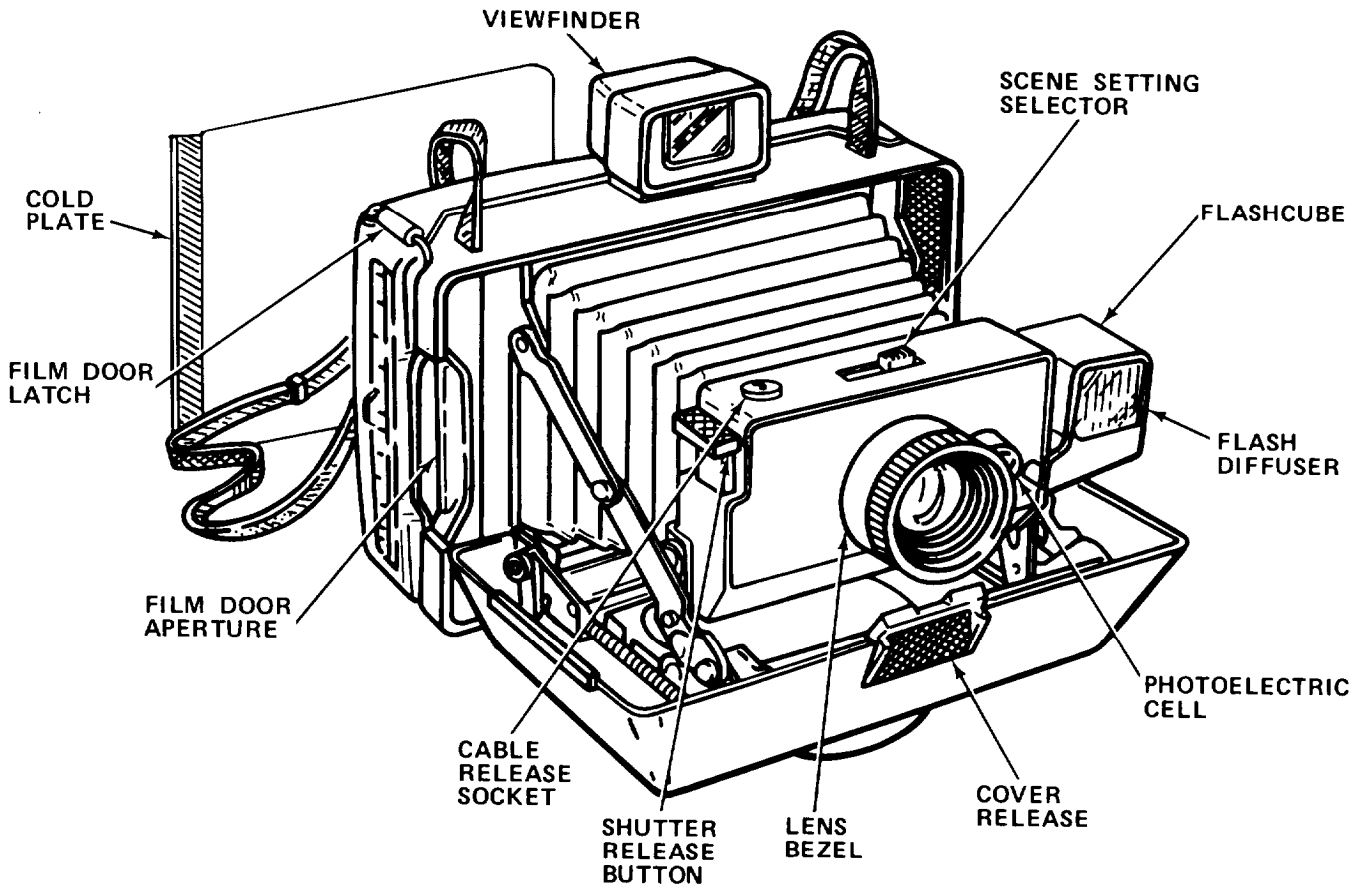

Viewfinder

Contains framing lines for series film in use.

Scene Setting Selector

Settings for outdoors, flash.

Flashcube

Automatically advances as exposures are made.

Photoelectric Cell

Measures reflected light from subject.

Flash Diffuser

Prevents overillumination of close subjects.

---

Control or Indicator	Function
Cover Release	Locks camera door.
Lens Bezel	Scale for setting estimated distance to subject.
Shutter Release Button	Activates shutter and flashcube (if used).
Cable Release Socket	For optional cable release.
Film Door Aperture	Photographs are pulled out here.
Film Door Latch	Locks film door shut.
Cold Plate	Assists in developing color prints in cold weather. (Stored in back cover when not in use.)

---

## 9-5. OPERATOR PREVENTIVE MAINTENANCE CHECKS AND SERVICES

- a. Before You Operate. Always keep in mind the WARNINGS and CAUTIONS. Perform your before (B) PMCS.
- b. While You Operate. Always keep in mind the WARNINGS and CAUTIONS. Perform your during (D) PMCS.
- c. After You Operate. Be sure to perform your after (A) PMCS.
- d. If Your Equipment Fails To Operate. Troubleshoot with proper equipment. Report any deficiencies using the proper forms. See DA Pam 738-750.

### 9-5.1 PMCS Procedures.

- a. PMCS are designed to keep the equipment in good working condition by performing periodic service tasks.
- b. Service intervals provide you, the operator, with time schedules that determine when to perform specified service tasks.
- c. The "Equipment is Not Ready/Available If" column is used for identification of conditions that make the equipment not ready/available for readiness reporting purposes or denies use of the equipment until corrective maintenance is performed.
- d. If your equipment fails to operate after PMCS is performed, immediately report this condition to your supervisor.
- e. Perform weekly as well as before operation if you are the assigned operator and have not operated the item since the last weekly or if you are operating the item for the first time.
- f. Item number column. Item numbers are assigned in chronological ascending sequence regardless of interval designation. These numbers are used for your "TM Number" column on DA Form 2404, Equipment Inspection and Maintenance Worksheet in recording results of PMCS.
- g. Interval columns. This column determines the time period designated to perform your PMCS.
- h. Item to be inspected and procedures column. This column lists functional groups and their respective assemblies and subassemblies as shown in the Maintenance Allocation Chart (Appendix B). The appropriate check or service procedure follows the specific item to be inspected.
- i. Equipment is not ready/available if: column. This column indicates the reason or cause why your equipment is not ready/available to perform its primary mission.

j. List of equipment, tools and materials required for PMCS is as follows:

<u>Equipment</u>	<u>Items</u>	<u>Quantity</u>
Optical Tree Measurer	Dusting Brush	1 ea
	Lens Tissue (Item 23, Appendix E)	ar
	Lens Cleaner (Item 4, Appendix E)	ar
Still Picture (Instant) Camera Set	Watchmaker's Blower	1 ea
	Lens Tissue (Item 23, Appendix E)	ar
	Denatured Alcohol (Item 3, Appendix E)	ar
	Cotton Swabs (Item 6, Appendix E)	ar
	Batteries (Size AA 1.5V)	2 ea
Air Velocity Meter	Cleaner, Wire Pipe (Item 14, Appendix E)	ar
Magnifier Lamp	Lens Cleaner (Item 4, Appendix E)	ar
	Cheesecloth (Item 5, Appendix E)	1 ea
Manual Typewriter	Typewriter Ribbon	1 ea
Optical Range Finder	Lens Tissue (Item 23, Appendix E)	ar
	Lens Cleaner (Item 4, Appendix E)	ar
Pocket Stereoscope	Lens Tissue (Item 23, Appendix E)	ar

Table 9-1. OPERATOR PREVENTIVE MAINTENANCE CHECKS AND SERVICES

NOTE

If the equipment must be kept in continuous operation, check and service only those items that can be checked and serviced without disturbing operation. Make the complete checks and services when the equipment can be shut down.

B - Before  
D - During  
A - After

W - Weekly  
M - Monthly  
Q - Quarterly

AN - Annually  
S - Semiannually  
BI - Biennially

(Number) - Hundreds of Hours

ITEM NO.	INTERVAL	ITEM TO BE INSPECTED  PROCEDURE	For Readiness Reporting, Equipment Is Not Ready/ Available If:
<b>SUPPORT ITEMS</b>			
1	B	<u>Magnifier Lamp.</u>  1. Inspect lens for cracks, breaks, or dirt. Clean as required.  2. Inspect arms and base for cracks or breaks.	Lens cracked or broken.  Arms or base cracked or broken.
2	B	<u>Service Magnifier Lamp.</u>  1. Turn off magnifier lamp.  2. Apply small amount of liquid lens cleaner to lens and wipe clean with cheesecloth.  3. Turn on magnifier lamp.	
3	Q	<u>Vacuum Cleaner.</u>  Inspect vacuum cleaner for damage to housing, frayed or worn power cord, and proper operation of motor.	Cracked or broken housing. Frayed, worn or damaged power cord or plug. Noisy or improper motor operation.



Table 9-1. OPERATOR PREVENTIVE MAINTENANCE CHECKS AND SERVICES - Cont

B - Before  
D . During  
A After

W - Weekly  
M - Monthly  
Q - Quarterly

AN - Annually  
S - Semiannually  
BI - Biennially

(Number) - Hundreds of Hours

ITEM NO.	IN-TER VAL	ITEM TO BE INSPECTED  PROCEDURE	For Readiness Reporting, Equipment Is Not Ready/ Available If:
<b>SUPPORT ITEMS - Cont</b>			
4	B	<p><u>Clean Pocket Stereoscope.</u></p> <ol style="list-style-type: none"> <li>1. Inspect lenses for dust, dirt, cracks, or breaks.</li> <li>2. Clean lenses with lens tissue.</li> <li>3. Inspect housing and legs for cracks or breaks.</li> </ol>	
5	B	<p><u>Inspect Pin Punch Resister.</u></p>  <p>Check punch die for buildup of punched out material and clean as required.</p>	
6	B	<p><u>Paper Trimmer.</u> Inspect paper trimmer for structural damage and proper operation of blade.</p>	Blade will not operate.

Table 9-1. OPERATOR PREVENTIVE MAINTENANCE CHECKS AND SERVICES - Cont

B - Before  
D - During  
A - After

W - Weekly  
M - Monthly  
Q - Quarterly

AN - Annually  
S - Semiannually  
BI - Biennially

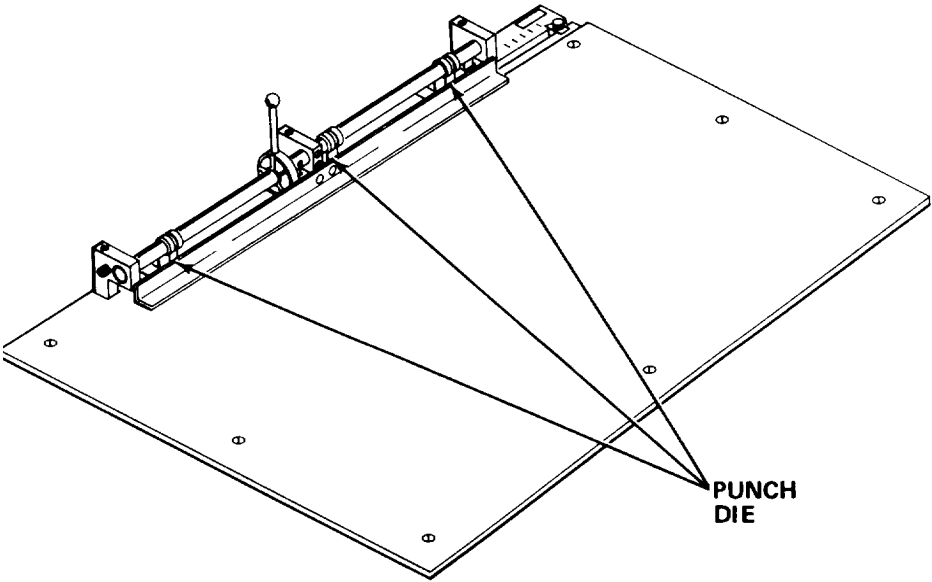
(Number) - Hundreds of Hours

ITEM NO.	INTERVAL	ITEM TO BE INSPECTED  PROCEDURE	For Readiness Reporting, Equipment Is Not Ready/ Available If:
<b>SUPPORT ITEMS - Cont</b>			
7	W	<p data-bbox="277 537 565 569"><u>Manual Typewriter.</u></p>  <ol data-bbox="285 1329 1016 1549" style="list-style-type: none"> <li>1. Remove dust cover.</li> <li>2. Check that typewriter is mounted securely.</li> <li>3. Check that typewriter ribbon is installed.</li> <li>4. Replace dust cover.</li> </ol>	
8	S	<p data-bbox="285 1612 1036 1644"><u>Replace Typewriter Ribbon on Manual Typewriter.</u></p> <p data-bbox="285 1675 1089 1738">Refer to your operator's manual for replacement of ribbon.</p>	

Table 9-1. OPERATOR PREVENTIVE MAINTENANCE CHECKS AND SERVICES - Cont

B - Before  
D - During  
A - After

W - weekly  
M - Monthly  
Q - Quarterly

AN . Annually  
S - Semiannually  
BI - Biennially

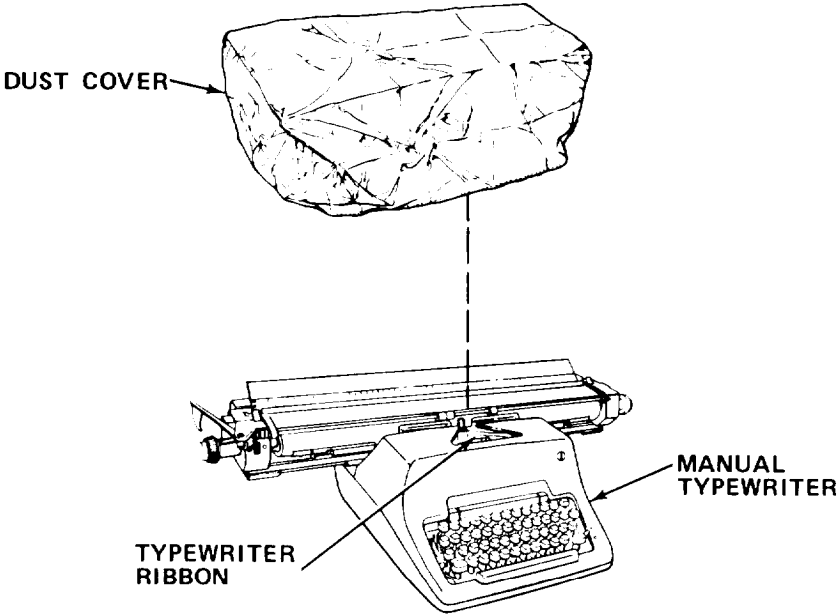
(Numbered - Hundreds of Hours)

ITEM NO.	IN-TER-VAL	ITEM TO BE INSPECTED  PROCEDURE	For Readiness Reporting, Equipment Is Not Ready/ Available If:
<b><u>SUPPORT ITEMS - Cont</u></b>			
9	B	<u>Hand Psychrometer.</u>  1. Remove hand psychrometer from carrying case.  2. Check for missing or dirty wick on wet bulb.  3. Inspect thermometers. Be sure there are no cracks or illegible numerals.  4. Be sure air ducts and air intake are clear of debris. Clean as necessary.	Wick is missing or dirty.  Thermometer is cracked or numerals are illegible.
10	B	<u>Hand Psychrometer Lamp, Motor, and Bottle.</u>  1. Install batteries.  2. Turn switch fully to right, and check light and motor operation.  3. Check water bottle for cracks or deterioration. Fill water bottle.	Motor does not operate.

Table 9-1. OPERATOR PREVENTIVE MAINTENANCE CHECKS AND SERVICES - Cont

B - Before  
D - During  
A - After

W - Weekly  
M - Monthly  
Q - Quarterly

AN - Annually  
S - Semiannually  
BI - Biennially

(Number) - Hundreds of Hours

ITEM NO.	INTERVAL	ITEM TO BE INSPECTED  PROCEDURE	For Readiness Reporting Equipment Is Not Ready/ Available If:
<b>SUPPORT ITEMS - Cont</b>			
11	B	<p data-bbox="277 541 711 571"><u>Inspect Air Velocity Meter.</u></p> <ol data-bbox="277 604 1096 1705" style="list-style-type: none"> <li>Remove meter from plastic case.</li> <li>Examine meter for cracks or damage to plastic body.</li> <li>Tip meter upside down and check that pith ball runs full length of indicating tube without sticking.</li> <li>Examine air inlet hoses. They must be free of obstructions.</li> <li>Examine scale change orifice. It must be free of obstructions.</li> <li>Examine calibration orifice. It must be free of obstructions.</li> </ol>	<p data-bbox="1247 1201 1437 1255">Plastic body has cracks.</p> <p data-bbox="1247 1297 1421 1381">The pith ball sticks at one end.</p> <p data-bbox="1247 1423 1388 1507">Air inlet hoses are clogged.</p> <p data-bbox="1247 1549 1453 1604">Scale orifice is clogged.</p> <p data-bbox="1247 1646 1421 1730">Calibration orifice is clogged.</p>

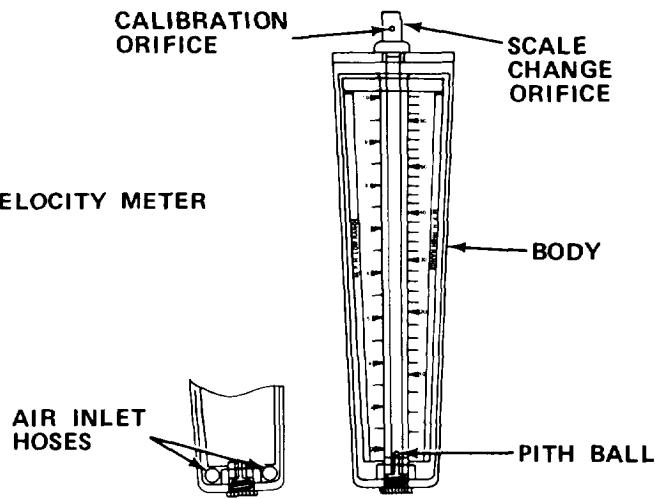

Table 9-1. OPERATOR PREVENTIVE MAINTENANCE CHECKS AND SERVICES - Cont

B - Before  
D - During  
A - After

W - Weekly  
M - Monthly  
Q - Quarterly

AN - Annually  
S - Semiannually  
BI - Biennially

(Number) - Hundreds of Hours

ITEM NO.	INTERVAL	ITEM TO BE INSPECTED  PROCEDURE	For Readiness Reporting, Equipment Is Not Ready/ Available If:
12	Q	<p><u>SUPPORT ITEMS - Cont</u></p> <p><u>Service Air Velocity Meter.</u></p> <p>1. Remove meter from plastic case.</p> <p style="text-align: center;"><b><u>CAUTION</u></b></p> <ul style="list-style-type: none"> <li>• To avoid damaging pith ball, place pith ball in safe place when cleaning indicator tube.</li> <li>• Avoid handling pith ball. If handling is essential, then do so gently.</li> </ul> <div style="text-align: center;">  <p>The diagram shows a vertical air velocity meter. At the top, there are two small openings labeled 'SCALE CHANGE ORIFICE' and 'CALIBRATION ORIFICE'. The main body is a graduated 'INDICATOR TUBE' containing a 'PITH BALL'. At the bottom, there are 'AIR INLET HOLES' which are partially covered by a cap. A separate view shows the cap being removed from the bottom.</p> </div> <p>2. Remove cap from bottom end of indicator tube.</p>	<p>Cap is missing.</p>

Table 9-1. OPERATOR PREVENTIVE MAINTENANCE CHECKS AND SERVICES - Cont

B - Before  
D - During  
A - After

W - Weekly  
M - Monthly  
Q - Quarterly

AN - Annually  
S - Semiannually  
BI - Biennially

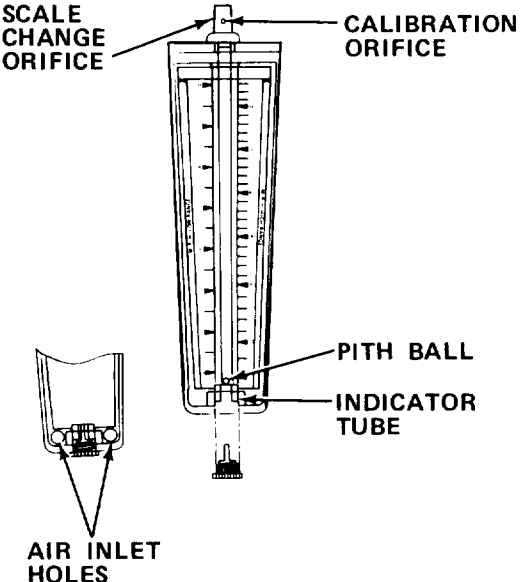
(Number) - Hundreds of Hours

ITEM NO.	INTERVAL	ITEM TO BE INSPECTED  PROCEDURE	For Readiness Reporting, Equipment Is Not Ready/ Available If:
12	Q	SUPPORT ITEMS - Cont	
		<p data-bbox="269 531 797 562"><u>Service Air Velocity Meter - Cont</u></p> <ol style="list-style-type: none"> <li data-bbox="269 594 1052 657">3. Tip meter to remove pith ball. Place in safe location.</li> <li data-bbox="269 720 1149 814">4. Place supplied chemically treated pipe cleaner in bottom of tube and clean entire length of indicator tube.</li> <li data-bbox="269 846 1049 877">5. Clean scale change orifice with pipe cleaner.</li> </ol> <p data-bbox="662 1003 737 1035" style="text-align: center;"><b>NOTE</b></p> <p data-bbox="354 1066 1138 1224">Do not use wire or pins to clean calibration orifice. This can permanently change calibration accuracy. Use only nylon cleaning bristle supplied with meter or chemically treated pipe cleaner.</p> <ol style="list-style-type: none"> <li data-bbox="269 1287 1062 1350">6. Clean calibration orifice by gently inserting pipe cleaner.</li> <li data-bbox="269 1381 979 1413">7. Clean air inlet holes with pipe cleaner.</li> <li data-bbox="269 1444 1076 1476">8. Carefully place pith ball into indicator tube.</li> <li data-bbox="269 1507 727 1539">9. Replace cap and tighten.</li> </ol>	<p data-bbox="1230 594 1422 688">Pith ball is missing or damaged.</p> <p data-bbox="1230 720 1377 814">Indicator tube is cracked.</p> <p data-bbox="1230 846 1422 940">Scale change orifice is cracked.</p> <p data-bbox="1230 1287 1422 1381">Calibration orifice is cracked.</p>

Table 9-1. OPERATOR PREVENTIVE MAINTENANCE CHECKS AND SERVICES - Cont

B - Before  
D - During  
A - After

W - Weekly  
M - Monthly  
Q - Quarterly

AN - Annually  
S - Semiannually  
BI - Biennially

(Number) - Hundreds of Hours

ITEM NO.	INTERVAL	ITEM TO BE INSPECTED  PROCEDURE	For Readiness Reporting, Equipment Is Not Ready/ Available If:
13	B	<p>SUPPORT ITEMS - Cont</p> <p><u>Optical Range Finder.</u></p>  <ol style="list-style-type: none"> <li>1. Remove range finder from case.</li> <li>2. Inspect instrument for broken case or missing parts and screws.</li> <li>3. Rotate range dial. Observe free movement.</li> <li>4. Attach six-power telescope by alining dovetail and pushing downward until positive lock engages.</li> <li>5. Place eye to lens and focus. Observe clear vision.</li> <li>6. Observe yellow and blue images.</li> <li>7. Rotate range ring. Observe that yellow and blue images move toward and away from each other.</li> </ol>	<p>Case is broken. Parts and/or screws are missing.</p> <p>Dial will not rotate</p> <p>Six power telescope is missing.</p> <p>Unable to focus .</p> <p>No image present.</p> <p>Range ring will not rotate.</p>

Table 9-1. OPERATOR PREVENTIVE MAINTENANCE CHECKS AND SERVICES - Cont

B - Before  
D - During  
A - After

W - Weekly  
M - Monthly  
Q - Quarterly

AN - Annually  
S - Semiannually  
BI - Biennially

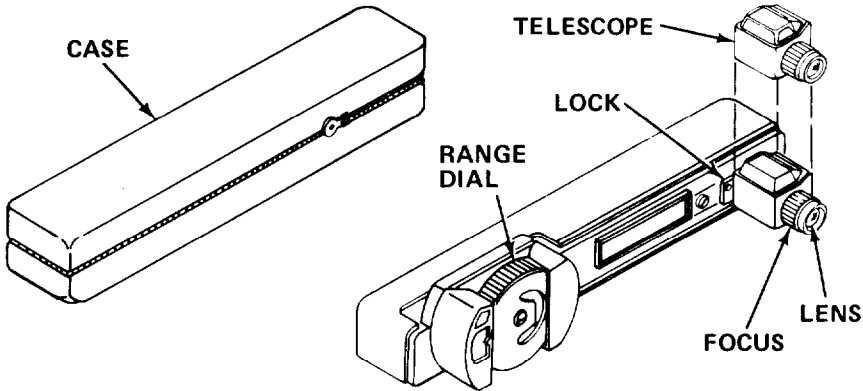
(Number) - Hundreds of Hours

ITEM NO.	INTERVAL	ITEM TO BE INSPECTED  PROCEDURE	For Readiness Reporting, Equipment Is Not Ready/ Available If:
14	B	<p>SUPPORT ITEMS - Cont</p> <p><u>Clean Optical Range Finder.</u></p> <ol style="list-style-type: none"> <li>Moisten lens tissue with lens cleaning fluid.</li> </ol>  <ol style="list-style-type: none"> <li>Gently wipe lens with moistened tissue using circular motion.</li> <li>Use clean, dry lens tissue to wipe lens dry.</li> <li>Repeat procedure for each of two remaining lenses using clean lens tissue moistened with lens cleaning fluid for each lens. Use clean, dry tissue to dry each lens.</li> </ol>	<p>Lens scratched or broken.</p>



Table 9-1. OPERATOR PREVENTIVE MAINTENANCE CHECKS AND SERVICES - Cont

B - Before  
D - During  
A - After

W - Weekly  
M - Monthly  
Q - Quarterly

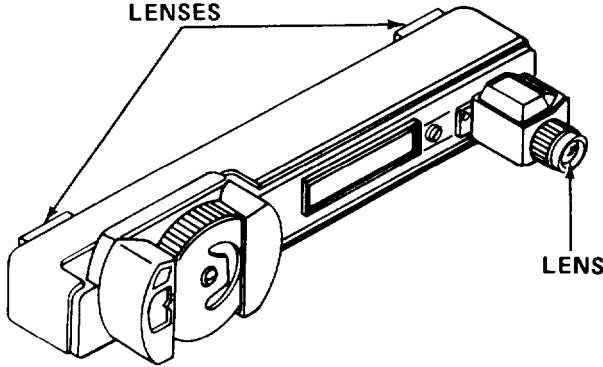
AN - Annually  
S - Semiannually  
BI - Biennially

(Number) - Hundreds of Hours

ITEM NO.	INTERVAL	ITEM TO BE INSPECTED  PROCEDURE	For Readiness Reporting, Equipment Is Not Ready/ Available If:
15	B	<p>SUPPORT ITEMS - Cont</p> <p><u>Optical Tree Measurer.</u></p>  <p>CARRYING CASE</p> <ol style="list-style-type: none"> <li>Inspect carrying case for broken stitching and rot.</li> </ol>  <p>CARRYING STRAP</p> <p>LENSES</p> <ol style="list-style-type: none"> <li>Inspect carrying strap for secure attachment to instrument.</li> </ol>	<p>Carrying case has broken stitching.</p> <p>Carrying case rotten.</p> <p>Carrying strap missing.</p>

Table 9-1. OPERATOR PREVENTIVE MAINTENANCE CHECKS AND SERVICES - Cont

B - Before  
D - During  
A - After

W - Weekly  
M - Monthly  
Q - Quarterly

AN - Annually  
S - Semiannually  
BI - Biennially

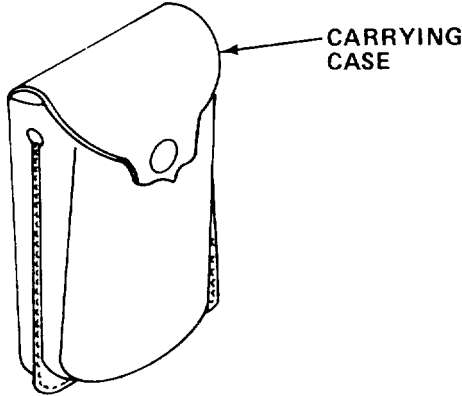
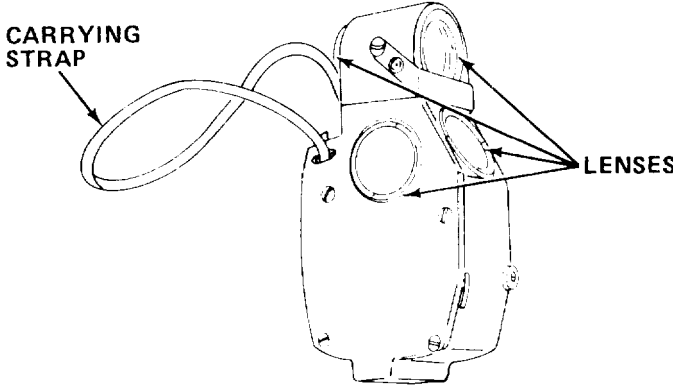
(Number) - Hundreds of Hours

ITEM NO.	INTERVAL	ITEM TO BE INSPECTED  PROCEDURE	For Readiness Reporting, Equipment Is Not Ready/ Available If:
15	B	<p>SUPPORT ITEMS - Cont</p> <p>Optical Tree Measurer - Cont</p> <p>3. Inspect instrument for missing screws and cracked lenses.</p> <div data-bbox="574 719 1049 1004" data-label="Image"> </div> <p>4. Observe target. Note visible scale in bottom. half of view field does not move as instrument is inclined.</p>	<p>Screws are missing or lens(es) are cracked.</p> <p>Unable to see target. Visible scale moves as instrument is inclined.</p>

Table 9-1. OPERATOR PREVENTIVE MAINTENANCE CHECKS AND SERVICES - Cont

B - Before  
D - During  
A - After

W - Weekly  
M - Monthly  
Q - Quarterly

AN - Annually  
S - Semiannually  
BI - Biennially

(Number) - Hundreds of Hours

ITEM NO.	INTERVAL	ITEM TO BE INSPECTED  PROCEDURE	For Readiness Reporting, Equipment Is Not Ready/ Available If:
15	B	<p data-bbox="370 442 692 472"><u>SUPPORT ITEMS - Cont</u></p> <p data-bbox="370 538 822 568"><u>Optical Tree Measurer - Cont</u></p> <div data-bbox="459 634 1219 1049"> </div> <p data-bbox="398 1140 1158 1200">5. Press release button. Observe that scale moves when instrument is inclined.</p> <p data-bbox="398 1330 1186 1389">6. Push shade upward and downward. Observe free movement.</p>	<p data-bbox="1339 1125 1529 1283">Scale does not move when release button is depressed.</p> <p data-bbox="1339 1315 1471 1374">Shade is frozen.</p>

Table 9-1. OPERATOR PREVENTIVE MAINTENANCE CHECKS AND SERVICES - Cont

B - Before  
D - During  
A - After

W - Weekly  
M - Monthly  
Q - Quarterly

AN - Annually  
S - Semiannually  
BI - Biennially

(Number) - Hundreds of Hours

ITEM NO.	INTERVAL	ITEM TO BE INSPECTED  PROCEDURE	For Readiness Reporting, Equipment Is Not Ready/ Available If:
16	B	<p>SUPPORT ITEMS - Cont</p> <p><u>Clean Optical Tree Measurer.</u></p>  <ol style="list-style-type: none"> <li>1. Brush dust or dirt from lens surfaces.</li> <li>2. Moisten lens tissue with lens cleaning fluid.</li> </ol>  <ol style="list-style-type: none"> <li>3. Wipe eyepiece lens tissue using circular motion working toward edge.</li> <li>4. Use clean, dry tissue and wipe lens surface dry.</li> </ol>	

Table 9-1. OPERATOR PREVENTIVE MAINTENANCE CHECKS AND SERVICES - Cont

B - Before  
D - During  
A - After

W - Weekly  
M - Monthly  
Q - Quarterly

AN - Annually  
S - Semiannually  
BI - Biennially

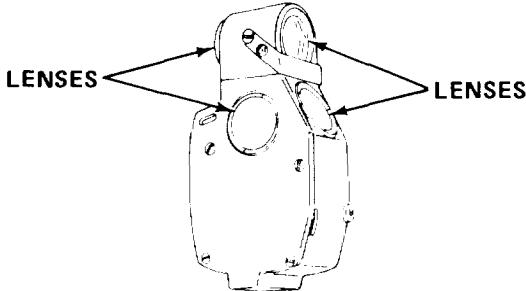
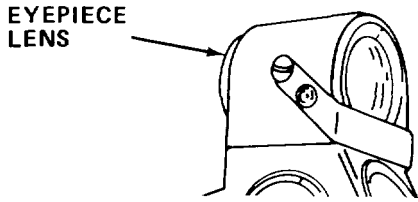
(Number) - Hundreds of Hours

ITEM NO.	INTERVAL	ITEM TO BE INSPECTED  PROCEDURE	For Readiness Reporting, Equipment Is Not Ready/ Available If:
16	B	<p>SUPPORT ITEMS - Cont</p> <p>Clean Optical Tree Measurer - Cont</p>  <p>5. Moisten clean tissue with lens cleaning fluid and wipe front lens using circular motion.</p> <p>6. Use clean, dry tissue to wipe lens surface dry.</p> <p>7. Moisten tissue with lens cleaning fluid and wipe each of three window lenses.</p> <p>8. Use clean, dry tissue to wipe three window lenses dry.</p>	

Table 9-1. OPERATOR PREVENTIVE MAINTENANCE CHECKS AND SERVICES - Cont

B - Before  
D - During  
A - After

W - Weekly  
M - Monthly  
Q - Quarterly

AN - Annually  
S - Semiannually  
BI - Biennially

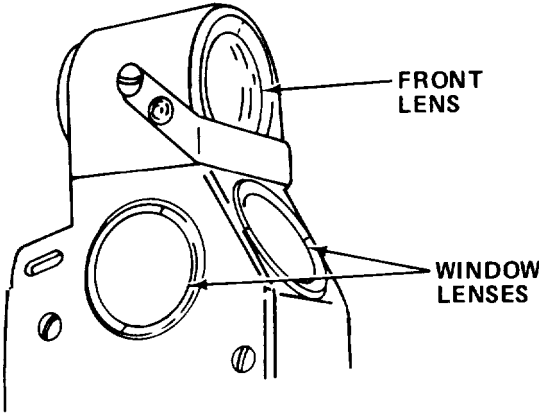
(Number) - Hundreds of Hours

ITEM NO.	INTERVAL	ITEM TO BE INSPECTED  PROCEDURE	For Readiness Reporting Equipment Is Not Ready/ Available If:
17	B	<p data-bbox="272 432 594 464"><u>SUPPORT ITEMS - Cont</u></p> <p data-bbox="272 527 769 558"><u>Still Picture (Instant) Camera.</u></p> <div data-bbox="318 617 1094 928">  </div> <ol data-bbox="302 1031 1062 1188" style="list-style-type: none"> <li data-bbox="302 1031 1062 1094">1. Press release on top of front cover to open, and turn camera latch.</li> <li data-bbox="302 1157 1062 1188">2. Inspect camera for broken or missing parts.</li> </ol> <p data-bbox="659 1278 790 1310" style="text-align: center;"><b><u>CAUTION</u></b></p> <p data-bbox="355 1356 1058 1419">Opening camera door when film pack. is loaded may ruin unexposed film.</p>	<p data-bbox="1235 1024 1422 1119">Release button is inoperative.</p> <p data-bbox="1235 1150 1401 1245">Parts are missing or broken.</p>

Table 9-1. OPERATOR PREVENTIVE MAINTENANCE CHECKS AND SERVICES - Cont

B - Before  
D - During  
A - After

W - Weekly  
M - Monthly  
Q - Quarterly

AN - Annually  
S - Semiannually  
BI - Biennially

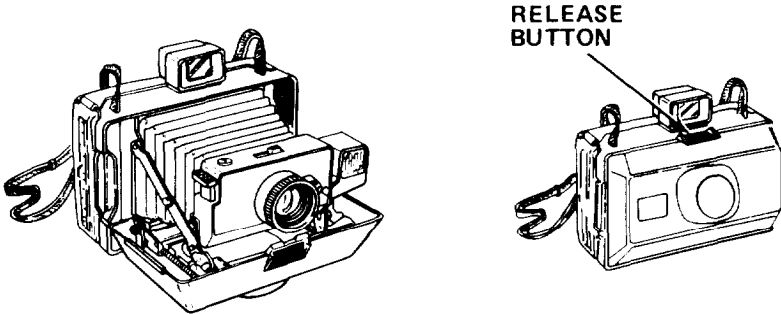
(Number) - Hundreds of Hours

ITEM NO.	IN-TER-VAL	ITEM TO BE INSPECTED  PROCEDURE	For Readiness Reporting, Equipment Is Not Ready/ Available If:
17	B	<b>SUPPORT ITEMS - Cont</b>	
		<p data-bbox="354 535 950 569"><u>Still Picture (Instant) Camera - Cont</u></p> <div data-bbox="699 600 1096 890" style="text-align: center;">  <p data-bbox="959 737 1096 762">APERTURE</p> </div> <p data-bbox="354 947 1224 1041">3. Inspect camera door aperture to be sure camera is not loaded with film pack. (No paper tabs show in slot.)</p> <div data-bbox="574 1083 883 1362" style="text-align: center;">  <p data-bbox="574 1178 651 1230">DOOR CLIP</p> </div> <p data-bbox="354 1421 1044 1453">4. Release door clip and open camera door.</p>	

Table 9-1. OPERATOR PREVENTIVE MAINTENANCE CHECKS AND SERVICES - Cont  
 B - Before AN - Annually (Number) - Hundreds of Hours  
 D - During W - Weekly  
 A - After M - Monthly S - Semiannually  
 CI - Quarterly BI - Biennially

ITEM NO.	INTERVAL	ITEM TO BE INSPECTED  PROCEDURE	For Readiness Reporting, Equipment Is Not Ready/ Available If:
<b>SUPPORT ITEMS - Cont</b>			
17	B	Still Picture (Instant) Camera - Cont	
			
		<p>5. Inspect film rollers for dirt or residue.</p> <p>6. Check that cold pack is in camera door.</p> <p>7. Inspect batteries for signs of corrosion, bulging or damage.</p>	<p>Film rollers have dirt and/or residue.</p> <p>Batteries are corroded and/or damaged.</p>
			
		<p>8. Hold lens of camera toward light and inspect bellows for light leaks by looking inside camera bellows.</p>	<p>Bellows has tears.</p>

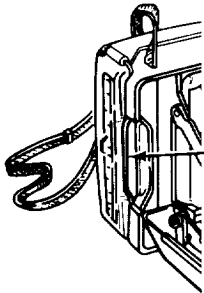
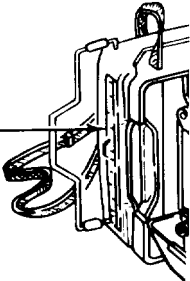

Table 9-1. OPERATOR PREVENTIVE MAINTENANCE CHECKS AND SERVICES - Cont

B - Before  
D - During  
A - After

W - Weekly  
M - Monthly  
Q - Quarterly

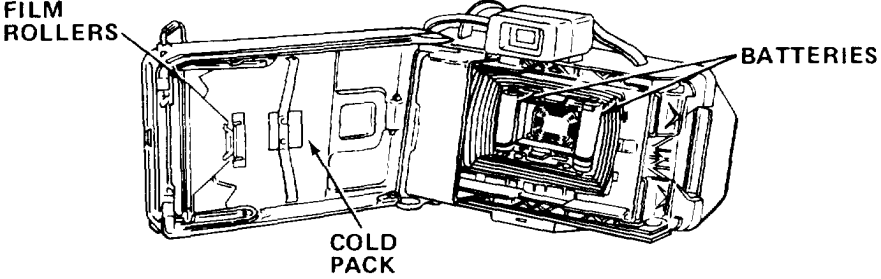
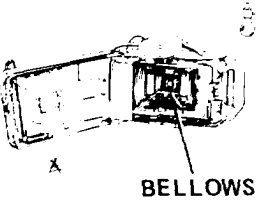
AN - Annually  
S - Semiannually  
BI - Biennially

(Number) - Hundreds of Hours

ITEM NO.	INTERVAL	ITEM TO BE INSPECTED  PROCEDURE	For Readiness Reporting, Equipment Is Not Ready/ Available If:
<b>SUPPORT ITEMS - Cont</b>			
17	B	<p><u>Still Picture (Instant) Camera - Cont</u></p> <p>9. Close camera door and snap latch.</p> <p>10. Press cover release button and close camera cover.</p>	
18	M	<p><u>Clean Still Picture (Instant) Camera.</u></p> <div style="display: flex; justify-content: space-around; align-items: center;">  </div> <p>1. Press cover release on top of front cover to open and latch camera.</p> <p style="text-align: center;"><b>CAUTION</b></p> <p>Opening camera door when film pack is loaded may ruin unexposed film.</p> <div style="display: flex; justify-content: center; align-items: center;">  </div> <p>2. Inspect film door aperture to be sure camera is not loaded with film pack. (No paper tabs show in slot).</p>	<p>Release button is inoperative.</p>

Table 9-1. OPERATOR PREVENTIVE MAINTENANCE CHECKS AND SERVICES - Cont

B - Before  
D - During  
A - After

W - Weekly  
M - Monthly  
Q - Quarterly

AN - Annually  
S - Semiannually  
BI - Biennially

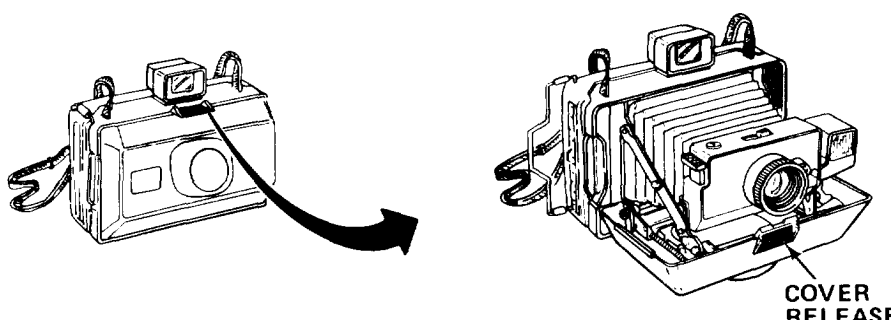
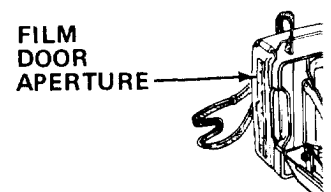
(Number) - Hundreds of Hours

ITEM NO.	INTERVAL	ITEM TO BE INSPECTED  PROCEDURE	For Readiness Reporting, Equipment Is Not Ready/ Available If:
<b>SUPPORT ITEMS - Cont</b>			
18	M	<p data-bbox="289 500 982 532"><u>Clean Still Picture (Instant) Camera - Cont</u></p> <div data-bbox="429 606 933 904">  <p data-bbox="429 680 520 734">DOOR LATCH</p> </div> <p data-bbox="305 1000 1098 1074">3. Release door latch and open camera door; then lay camera on working surface.</p> <div data-bbox="569 1138 1065 1489">  <p data-bbox="949 1170 1065 1223">CAMERA BACK</p> <p data-bbox="759 1425 900 1478">ROLLER ASSEMBLY</p> </div> <p data-bbox="322 1532 1123 1606">4. Use thumbs to push outward on roller assembly. Remove assembly.</p>	<p data-bbox="1247 1000 1428 1095">Door latch is inoperative.</p> <p data-bbox="1247 1532 1428 1627">Roller assembly is corroded.</p>

Table 9-1. OPERATOR PREVENTIVE MAINTENANCE CHECKS AND SERVICES - Cont

B - Before  
D - During  
A - After

W - Weekly  
M - Monthly  
Q - Quarterly

AN - Annually  
S - Semiannually  
BI - Biennially

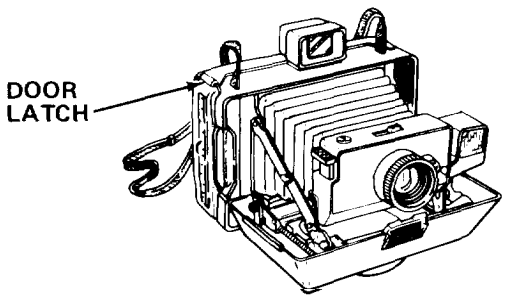
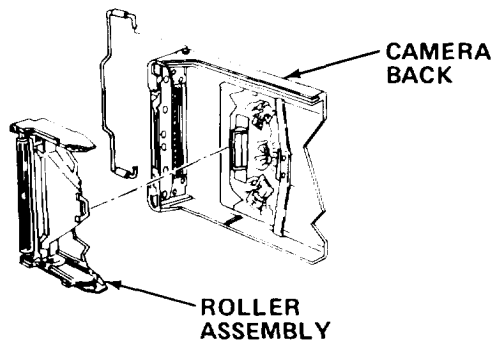
(Number) - Hundreds of Hours

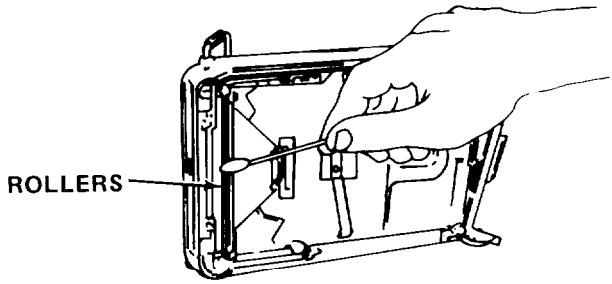
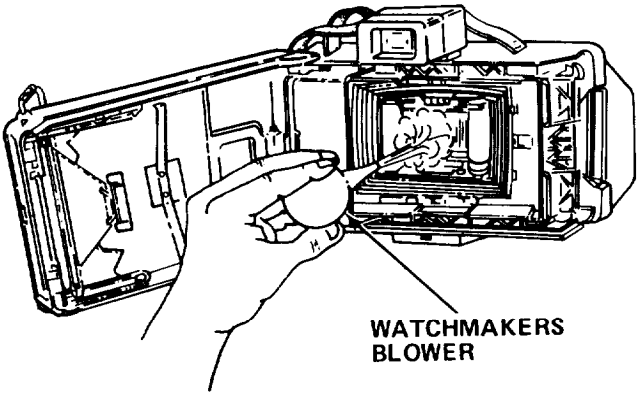
ITEM NO.	INTERVAL	ITEM TO BE INSPECTED  PROCEDURE	For Readiness Reporting, Equipment Is Not Ready/ Available If:
<b>SUPPORT ITEMS - Cont</b>			
18	M	<p data-bbox="342 533 1052 562"><u>Clean Still Picture (Instant) Camera - Cont</u></p> <div data-bbox="444 659 1052 940">  <p data-bbox="444 827 565 856">ROLLERS</p> </div> <p data-bbox="380 1037 1149 1129">5. Moisten cotton swab in denatured alcohol and swab rollers until all grime and residue are removed from rollers. Let rollers air dry.</p> <div data-bbox="500 1218 1133 1612">  <p data-bbox="867 1528 1062 1583">WATCHMAKERS BLOWER</p> </div> <p data-bbox="391 1701 1192 1759">6. Blow all dust and dirt from inside camera back and bellows with watchmaker's blower.</p>	

**Table 9-1. OPERATOR PREVENTIVE MAINTENANCE CHECKS AND SERVICES - Cont**  
 B - Before                      W - Weekly                      AN - Annually                      (Number) - Hundreds of Hours  
 D - During                      M - Monthly                      S - Semiannually  
 A - After                      Q - Quarterly                      BI - Biennially

ITEM NO.	INTERVAL	ITEM TO BE INSPECTED  PROCEDURE	For Readiness Reporting, Equipment Is Not Ready/ Available If:
<b>SUPPORT ITEMS - Cont</b>			
18	M	<p data-bbox="266 520 954 548"><u>Clean Still Picture (Instant) Camera - Cont</u></p> <ol style="list-style-type: none"> <li data-bbox="282 583 1065 674">7. Reinstall roller assembly by pressing plastic spring clip into roller assembly and pressing down until it snaps into place.</li> <li data-bbox="282 707 984 735">8. Close camera back and fasten door latch.</li> </ol> <div data-bbox="378 806 1179 1184" style="text-align: center;"> <p>A technical line drawing of a camera. A label 'VIEWFINDER' points to the top of the camera. A label 'PHOTOELECTRIC CELL LENS' points to the lens on the right side of the camera body. A label 'MAIN LENS' points to the lens in the front of the camera.</p> </div> <ol style="list-style-type: none"> <li data-bbox="282 1304 1143 1558">9. Gently wipe the following lenses with lens tissue using a clean tissue for each lens: <ul style="list-style-type: none"> <li data-bbox="430 1398 792 1425">Viewfinder (both sides)</li> <li data-bbox="430 1461 571 1488">Main lens</li> <li data-bbox="430 1524 703 1551">Electric eye lens</li> </ul> </li> <li data-bbox="282 1589 1049 1617">10. Press cover release button and close cover.</li> </ol>	<p data-bbox="1224 569 1401 659">Plastic spring clip missing.</p> <p data-bbox="1240 1295 1432 1383">Lens(es) are scratched or cracked.</p>

Table 9-1. OPERATOR PREVENTIVE MAINTENANCE CHECKS AND SERVICES - Cont

B - Before  
D - During  
A - After

W - Weekly  
M - Monthly  
Q - Quarterly

AN - Annually  
S - Semiannually  
BI - Biennially

(Number) - Hundreds of Hours

ITEM NO.	INTERVAL	ITEM TO BE INSPECTED  PROCEDURE	For Readiness Reporting, Equipment Is Not Ready/ Available If:
19	B	<p data-bbox="381 420 706 451"><u>SUPPORT ITEMS - Cont</u></p> <p data-bbox="381 514 1136 546"><u>Test Shutter on Still Picture (Instant) Camera.</u></p> <div data-bbox="381 588 1307 976"> </div> <ol data-bbox="406 1018 1193 1081" style="list-style-type: none"> <li>1. Press release button on top of front cover to open and latch camera.</li> </ol> <p data-bbox="730 1144 868 1176" style="text-align: center;"><b><u>CAUTION</u></b></p> <p data-bbox="470 1207 1185 1270">Opening camera door when film pack is loaded may ruin unexposed film.</p> <ol data-bbox="406 1333 1209 1438" style="list-style-type: none"> <li>2. Inspect camera door aperture to be sure camera is not loaded with film pack. (No paper tabs show in slot.)</li> </ol>	<p data-bbox="1339 1008 1526 1102">Release button is inoperative.</p>

Table 9-1. OPERATOR PREVENTIVE MAINTENANCE CHECKS AND SERVICES - Cont

B - Before  
D - During  
A - After

W - Weekly  
M - Monthly  
Q - Quarterly

AN - Annually  
S - Semiannually  
BI - Biennially

(Number) - Hundreds of Hours

ITEM NO.	INTERVAL	ITEM TO BE INSPECTED  PROCEDURE	For Readiness Reporting, Equipment Is Not Ready/ Available If:
19	B	<p><b>SUPPORT ITEMS - Cont</b></p> <p><u>Test Shutter on Still Picture (Instant) Camera - Cont</u></p>  <p>3. Release door latch and open camera door.</p> <p>4. Set scene selector to 75 (move to far right).</p> <p>5. Cover photoelectric cell lens with finger or cloth to block light.</p> <p>6. Look through lens from back of camera and press shutter release button.</p> <p>7. Observe that shutter opens and remains open.</p> <p>8. Uncover photoelectric cell. Observe that shutter closes.</p>	<p>Door latch is inoperative.</p> <p>Scene selector is inoperative.</p> <p>Shutter is inoperative.</p> <p>Shutter remains closed.</p> <p>Shutter remains open.</p>

Table 9-1. OPERATOR PREVENTIVE MAINTENANCE CHECKS AND SERVICES - Cont  
B - Before W - Weekly AN - Annually (Number) - Hundreds of Hours  
D - During M - Monthly S - Semiannually  
A - After Q - Quarterly BI - Biennially

ITEM NO.	INTERVAL	ITEM TO BE INSPECTED  PROCEDURE	For Readiness Reporting, Equipment Is Not Ready/ Available If:
19	B	<p><b>SUPPORT ITEMS - Cont</b></p> <p>Test Shutter on Still Picture (Instant) Camera.</p>  <p>9. If shutter does not close, replace batteries and repeat test.</p> <p style="text-align: center;"><b>NOTE</b></p> <p>If shutter fails with fresh batteries, camera must be replaced.</p> <p>10. Close camera door and latch with clip.</p>	

9-6. OPERATION UNDER USUAL CONDITIONS.

9-6.1 Assembly and Preparation for Use.

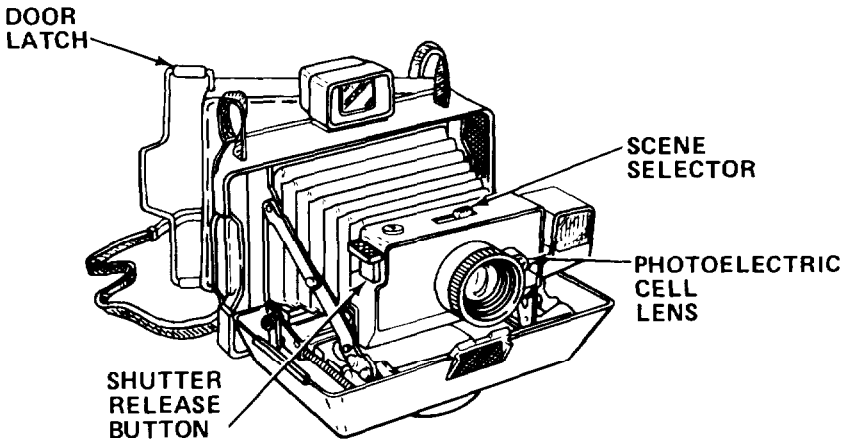
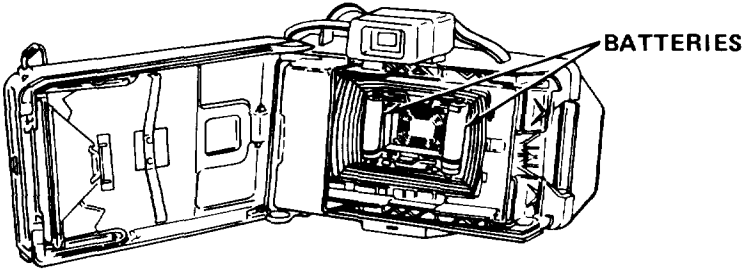
9-6.1.1 Manual Typewriter.

- a. Remove dust cover.

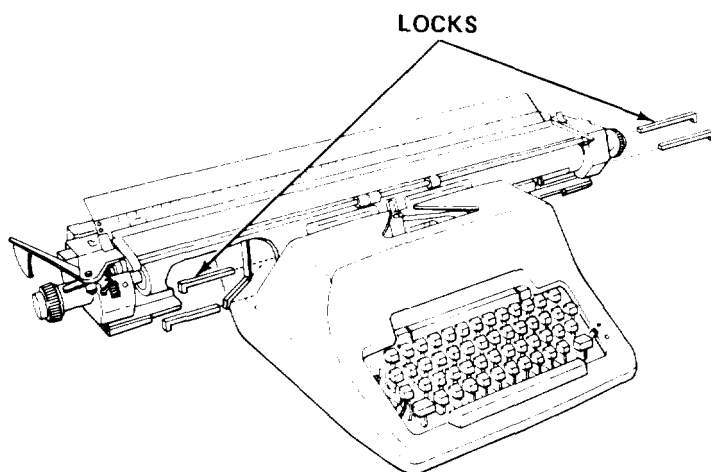
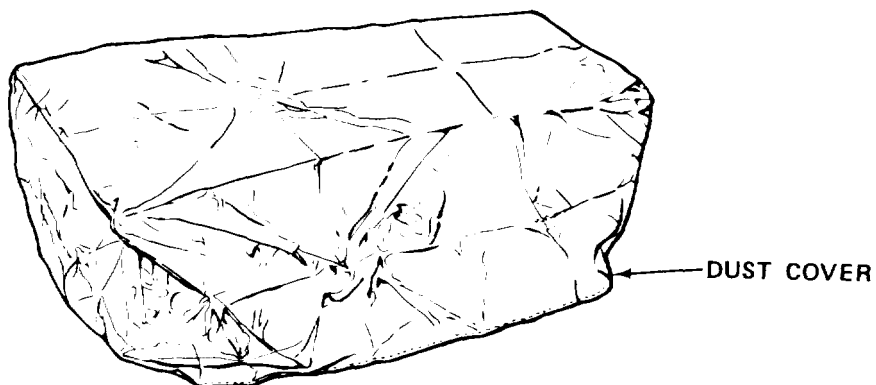

- b. Remove locks.



## 9-6.2 Operating Procedures.

### a. Magnifier lamp.

- (1) Move magnifier lamp from mounting bracket.
- (2) Plug in power cord.
- (3) Turn on fluorescent lamp.
- (4) Position magnifier lamp over object.
- (5) Examine object through lens.

### b. Vacuum cleaner.

- (1) Using as vacuum.
  - (a) Attach dust collection bag to air discharge opening.
  - (b) Remove protective screen lock from air intake opening and attach scrap trap to that opening.
  - (c) Attach swivel end of hose to scrap trap by turning lock to right until secure.
  - (d) Attach required tool to other end of hose.
  - (e) Insert plug into 120 V ac wall outlet and turn ON/OFF switch to ON.
- (2) Using as blower.
  - (a) Attach tapered rubber nozzle to discharge opening.
  - (b) Attach protective screen lock to air intake opening.
  - (c) Insert plug into 120 V ac wall outlet and turn ON/OFF switch to ON.
- (3) Using as sprayer.
  - (a) Attach protective screen lock to air intake opening.
  - (b) Attach swivel end of hose to air discharge opening by turning lock to right until secure.
  - (c) Attach sprayer to other end of hose.

### **NOTE**

Size of spray pattern is determined by adjusting screw located on top of sprayer.

(d) Insert plug into 120 V ac wall outlet and turn ON/OFF switch to ON.

c. Pocket stereoscope.

(1) Position photographs in preparation for viewing in stereo.

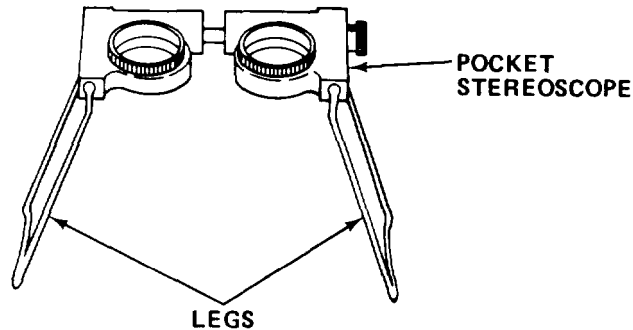

(2) Remove pocket stereoscope from case and unfold legs.

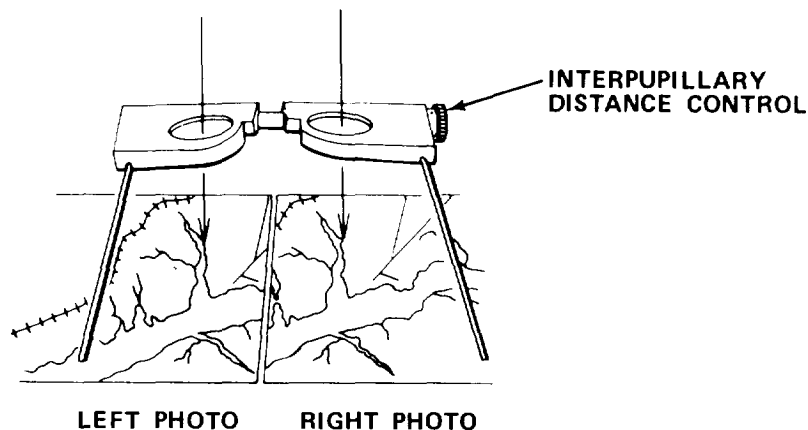

(3) Set pocket stereoscope on photos so that left lens is over left photograph and right lens is over right photograph.

(4) Adjust interpupillary distance between lenses until it matches that of viewer.

(5) Locate detail to be viewed on left photograph and center left lens over it.

(6) Move right photograph until the same detail is centered under right lens. When viewed simultaneously, two details should merge into one. Adjust photographs until this effect is achieved.

d. Pin punch register.

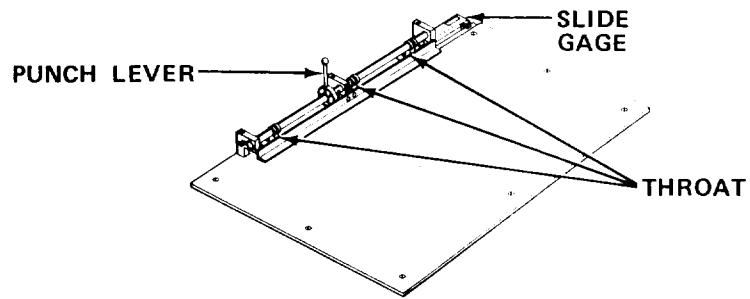

- (1) Remove from wall mount to working surface and attach punch lever.
- (2) Set slide gage to proper position.
- (3) Insert material into throat.
- (4) Press punch lever down and punch register holes.

e. Hand psychrometer.

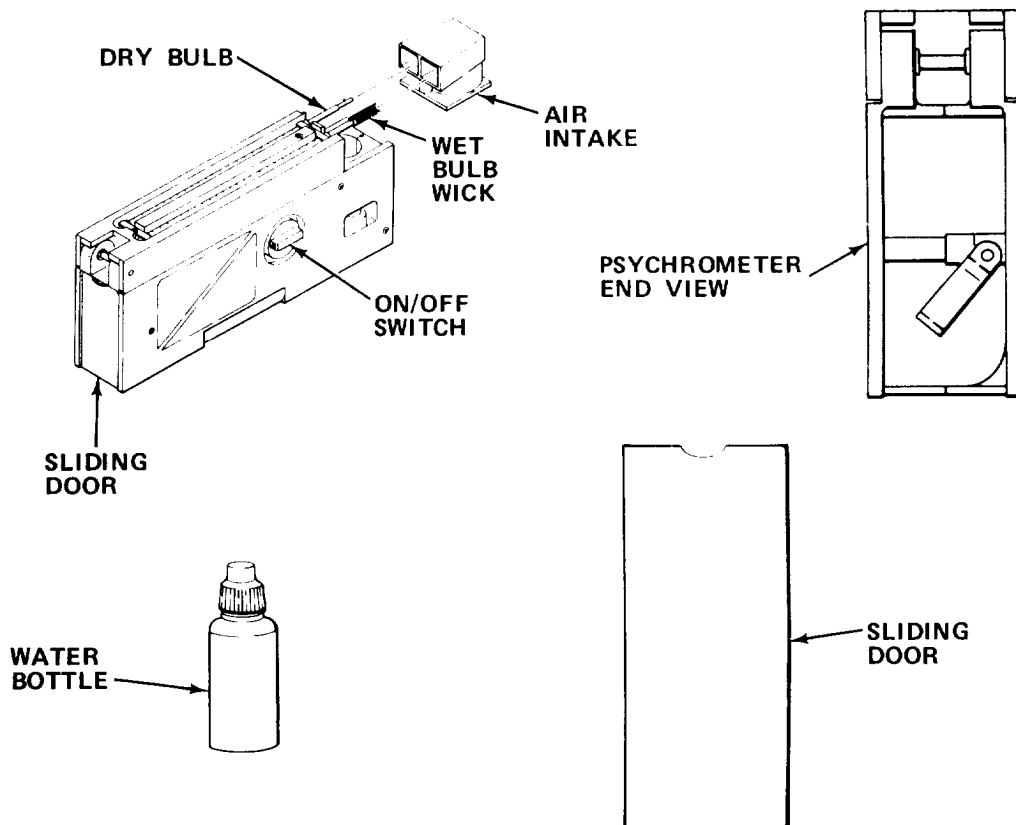

- (1) Open sliding door, remove water bottle, and close sliding door.

(2) Saturate wet bulb wick as follows:

(a) Remove air intake, turn psychrometer so wet bulb faces down, and thoroughly saturate wet bulb wick.

**NOTE**

Be sure no water contacts the thermometer tubes or the dry bulb. Remove any water spilled on the tubes or dry bulb.

(b) Replace sliding air intake, and turn right side up.

(3) Open sliding door, replace water bottle, and close sliding door.

**NOTE**

Whether placed on a bench or hand held, air intake and both exhaust ports must be entirely free of obstruction. The hand psychrometer samples air to which it is exposed. Care must be taken to use it far enough away from sources of heat, cold, or moisture. Be sure hand does not contact thermometers during use.

(4) Place hand psychrometer on flat surface or hold in hand with thermometer graduations facing up and air intake pointing to left.

**CAUTION**

Be sure to turn motor off after each observation. Unnecessary usage will greatly shorten life of batteries.

(5) Turn on/off switch ON and allow wet bulb temperature to stabilize.

(6) If thermometer illumination is desired, turn knob fully right.

**NOTE**

If wet bulb temperature fails to stabilize within 2.5 minutes after being energized, fan motor is probably running too slow due to weak batteries.

(7) Turn on/off switch OFF.

(8) Record wet and dry bulb temperatures.

(9) Read psychometric slide rule as follows:

(a) Aline wet bulb temperature and dry bulb temperature on slide rule.

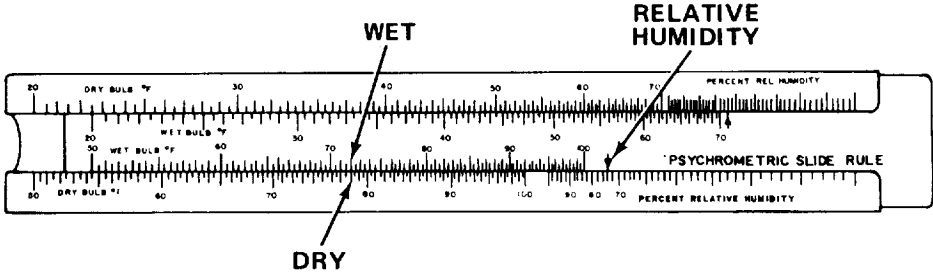

Example	wet bulb temp	72
	dry bulb temp	78
	% relative humidity	74 %

(b) Percentage value of relative humidity is indicated by arrow pointer on sliding center portion of the scale.

f. Air velocity meter.

- (1) Face into wind.
- (2) Hold meter in front of you in vertical position with scale side toward you.
- (3) Check that no part of your hand is blocking the bottom holes.
- (4) Height of pith ball indicates velocity. Read left-hand scale.

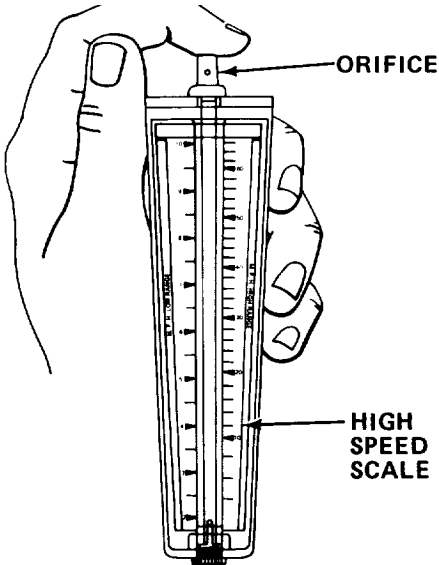

(5) If pith ball reaches top of left scale, place finger over orifice and read velocity on right high speed scale.

g. Optical range finder.

(1) Focus range finder.

(a) Place 6 X 18 monocular telescope into mounting.

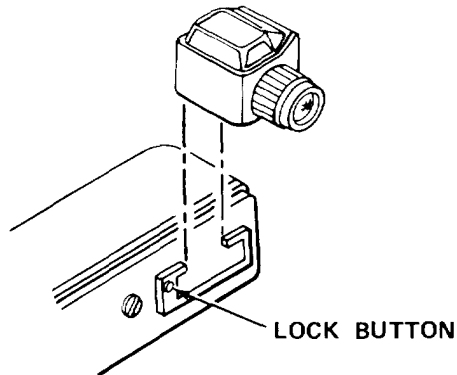

(b) Lock telescope by pressing down firmly on lock button.

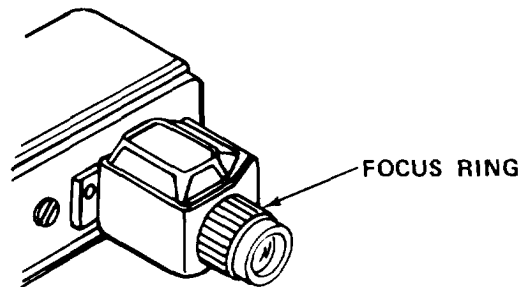

(c) Look through telescope and adjust focus ring until vision is sharp.

(2) Measure range.

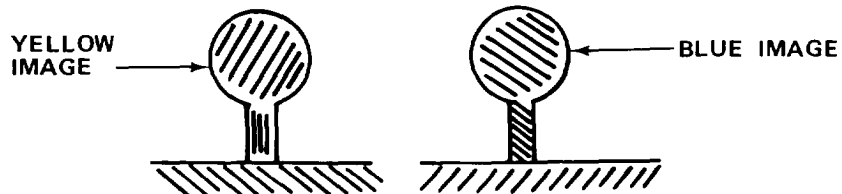

(a) Observe yellow and blue images.

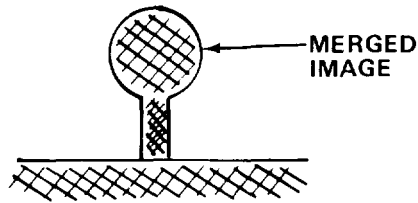

(b) Rotate range dial until images merge.

**NOTE**

If images will not merge, turn image adjustment screw.

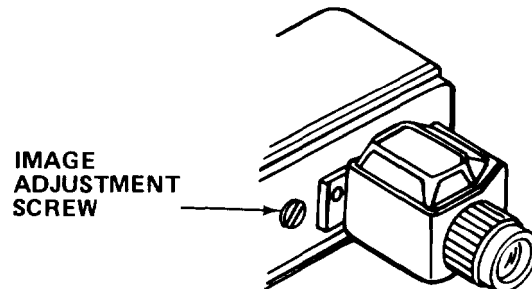
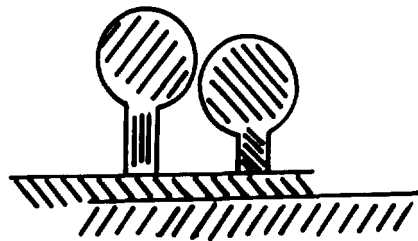

(c) Turn image adjustment screw to right or left until images are same height and merge. Use flat tip screwdriver to turn screw. (Screw slot is enlarged to permit emergency use of a coin to turn screw.)

(3) Read range scale (scale is in meters).

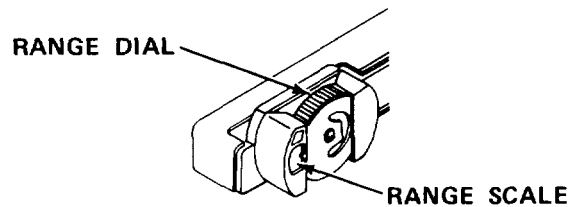

(4) Reset range scale.

**NOTE**

The following procedure is required if observed range does not equal known or measured range.

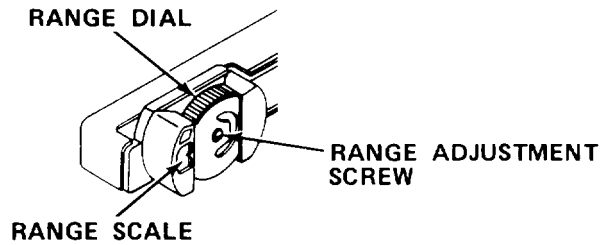

(a) Rotate range dial until images merge.

(b) Place coin or flat tip screwdriver in range adjustment screw slot.

(c) Hold screw position and force range dial to right or left until correct range is indicated.

(d) Repeat observation to confirm range is accurately set.

h. Optical tree measurer.

(1) Measurement of basal area:

(a) Observer chooses scale 1, 2 or 4 based on tree diameter. Choice of scale must be based on experience. Small-diameter trees are normally counted with scale 1, larger trees are counted with scale 2, and largest trees are counted with scale 4. The counting scale chosen should be representative of average size of visible trees and not be changed from sampling point to sampling point. Scales 1 and 2 are the most commonly used in forestry to determine basal area.

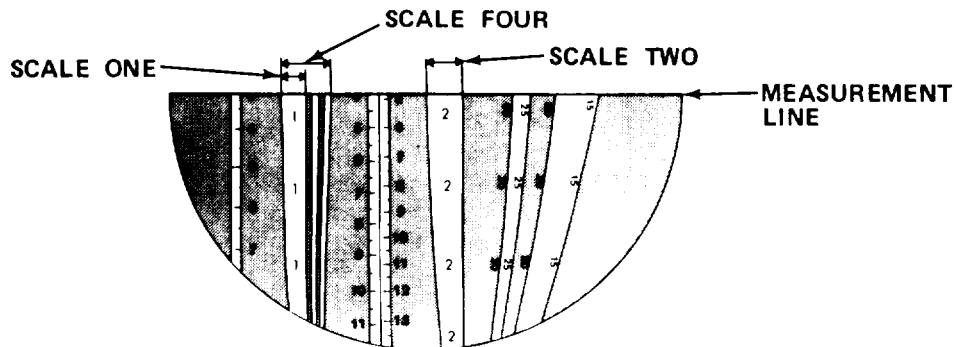

Example: Counting scale 2 is chosen if visible trees have an average diameter that is close to or slightly larger than scale 2.



(b) Observer stands at sampling point and aims instrument at diameter of all visible trees at breast height (DBH). (If a tree is partially obscured, observer should shift position, remaining at same distance from tree, to take reading on tree, and then move back to his original position.)

(c) Push release button to permit scale to shift.

(d) All trees that have a diameter wider than scale 2 are counted. Trees that have an equal diameter to scale 2 are not counted. Trees that have a diameter smaller than scale 2 are not counted.

(e) The number of trees counted are multiplied by the scale number (counting factor).

Example: Scale 2 - 32 trees counted.

$$2 \times 32 = 64$$

(f) The number of sampling points chosen is determined by area of tree stand, uniformity of tree stand and accuracy required.

If scale 4 is chosen for readings:

Area smaller than 4 hectares	Use 4 sampling points per hectare
Area 4-8 hectares	Use 3.8 sampling points per hectare
Area 8-16 hectares	Use 3.5 sampling points per hectare
Area 16-32 hectares	Use 3.1 sampling points per hectare
Area 32-64 hectares	Use 2.6 sampling points per hectare
Area greater than 64 hectares	Use 2 sampling points per hectare

If scale 2 is chosen, multiply above points by 0.6 to determine number of sampling points required.

If scale 1 is chosen, multiply above points by 0.4 to determine number of sampling points required.

#### NOTE

Choose sampling points at random. Do not choose convenient sampling points for accessibility, or sampling will be in error.

(g) Average values taken at each sampling point to determine basal area.

Example: Area is 7 hectares; area is between 4 and 8 hectares. Use 3.8 points per hectare.

$$3.8 \times 7 = 26.6$$

26.6 sampling points required. Scale 2 used; multiply by 0.6.

$$0.6 \times 26.6 = 15.96$$

Use next higher number: 16.

(h) Average readings at each of 16 points to determine basal area per hectare for entire area.

(2) Measurement of tree diameter. First determine distance from tree:

**NOTE**

Tree diameters may be measured from distances of 15, 20, 25 or 30 meters.

(a) A staff or stick 2 m (78.7 in.) is placed vertically against the tree.

(b) Aim instrument at middle of staff and push release button to free scale. Release button when scale is stabilized.

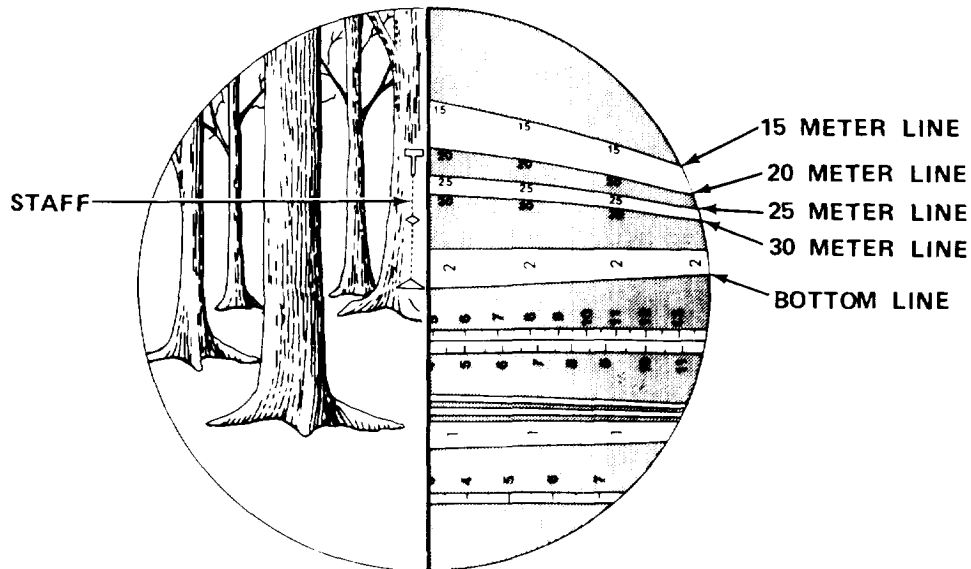

(c) Turn instrument 90° to the left, and move toward or away from staff until bottom of staff is aligned with bottom of scale 2 and top of staff reaches 15, 20, or 30 m line. Operator's distance from the tree is then 15, 20, 25 or 30 m.

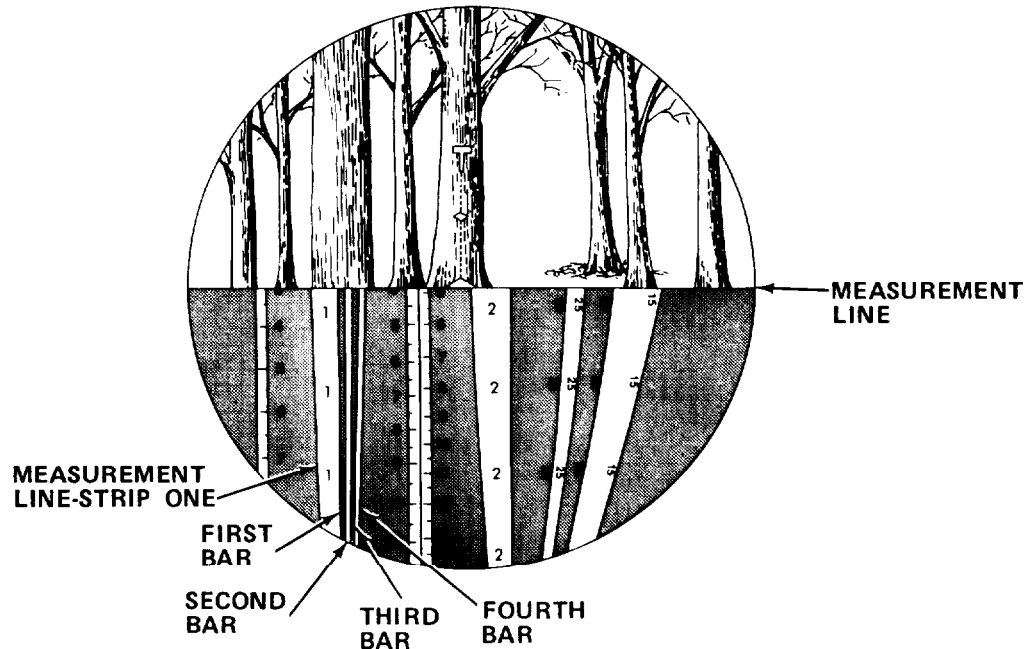

(d) Turn instrument 90° to the right and push release button. Make observation with left edge of strip 1 alined on left edge of tree. Tree diameter will be estimated by comparing it with wide, white strip 1 and four narrow bars next to it.

(e) At 15m, one-half of strip 1 covers 15 cm; entire strip covers 30 cm. At 20 m, one-half of strip 1 covers 20 cm; entire strip covers 40 cm. At 25 m, one-half of strip 1 covers 25 cm; entire strip covers 50 cm. At 30 m, one-half of strip 1 covers 30 cm; entire strip covers 60 cm. Each bar is one-fourth the width of the-strip.

Example: At 20 m, strip 1 covers 40 cm and each bar covers 10 cm. Strip 1 and all four bars cover 80 cm. At 25 m, strip one and all four bars cover 100 cm.

(f) The operator estimates tree diameter by observing tree alined at left edge of strip 1 and observing how far to the right it extends over scale. If tree diameter exceeds scale, the operator may increase his range from the tree, or he may measure segments of the tree and then total the segments.

#### NOTE

Dimensions that do not exactly agree with bars must be estimated. This method provides acceptable accuracy for forestry purposes.

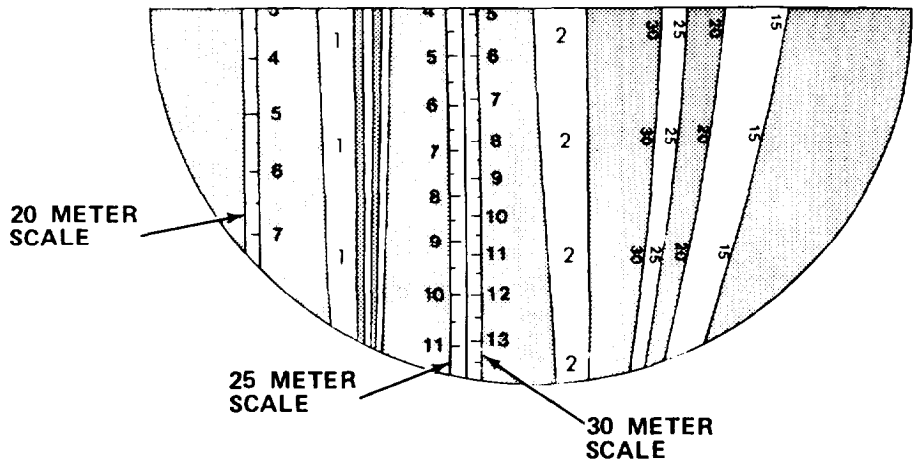

(3) Measurement of tree height. Three scales are provided to measure height at distances of 20, 25 or 30 m from the tree.

**NOTE**

Readings may be taken at 15 m by using half the reading on 30 m scale.

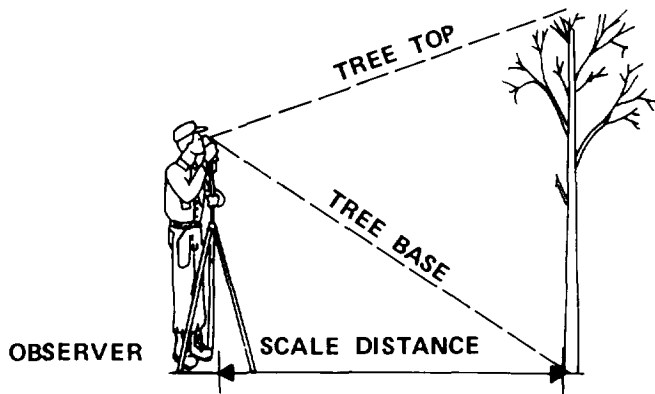

- (a) Observer takes distance from tree at 15, 20, 25, or 30 m.
- (b) Press release button and take reading at tree base. Record reading.
- (c) Press release button and take reading at tree top (or desired point). Record reading.

**NOTE**

Readings below horizontal line are negative; those above horizontal line are positive.

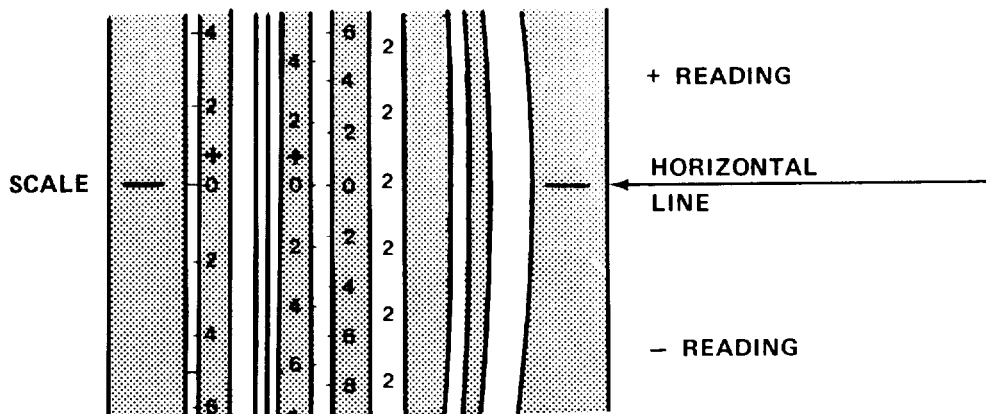

(d) If one reading is negative and the other reading is positive, add the two readings to obtain height. If both readings are the same (both positive or both negative), subtract the smaller reading from the larger reading to obtain height.

(4) Measurement of vertical angle as percent. To obtain percentage of slope:

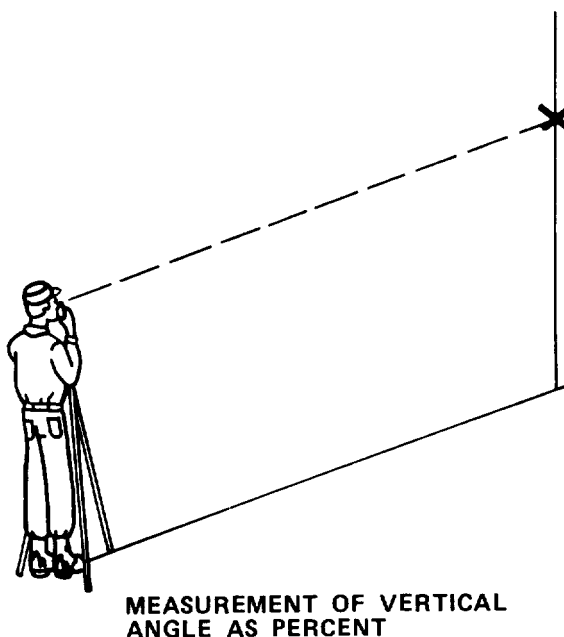

(a) Observer presses release button and takes observation on a point up slope (or down slope) which is at breast height.

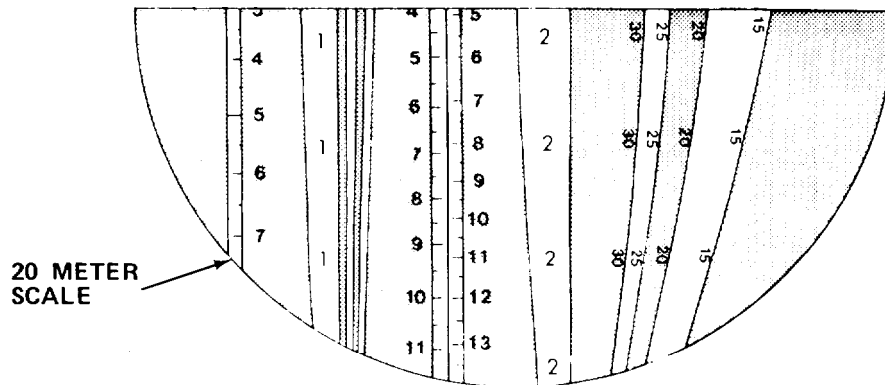

(b) Read 20 m scale and multiply reading by 5 to obtain percentage of slope.

i. Still picture (Instant) camera.

(1) Load camera.

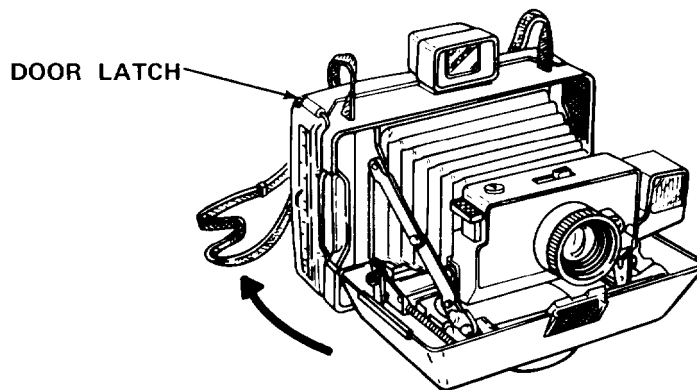

**DOOR WILL  
SWING OPEN**

(a) Release door latch.

(b) Door will swing open.

(c) Choose type of film: black and white or color. Open film pack.

**NOTE**

Do not press center of film pack. Hold film pack by edges only.

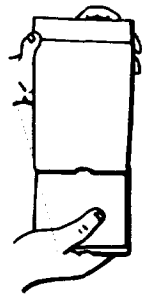

REMOVE FILM FROM BOX

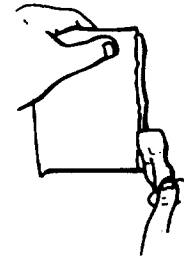
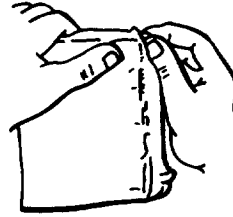

HOLD FILM BY EDGE AND REMOVE TEARSTRIP

(2) Load film pack.

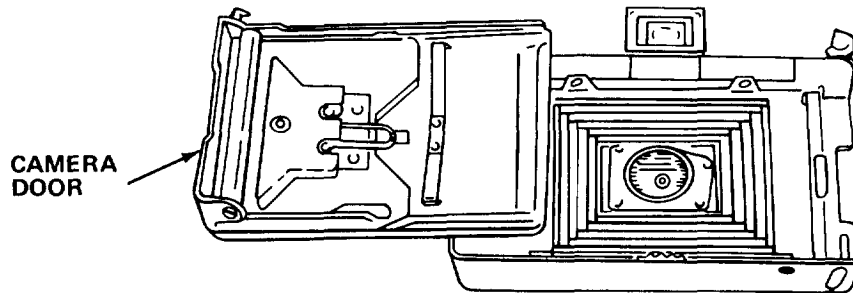

CAMERA DOOR

(a) Open camera door all the way.

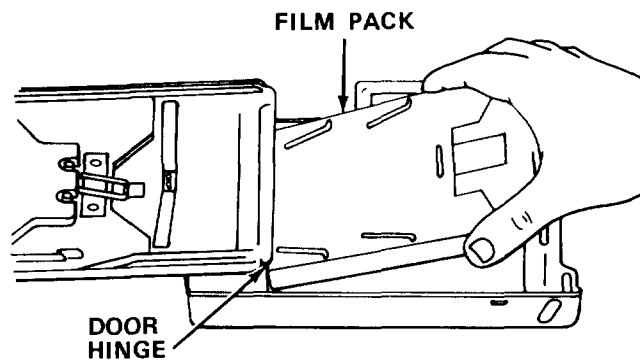

FILM PACK

DOOR HINGE

(b) Hold film pack by edges as shown. Push closed end of pack under door hinge, against spring tension.

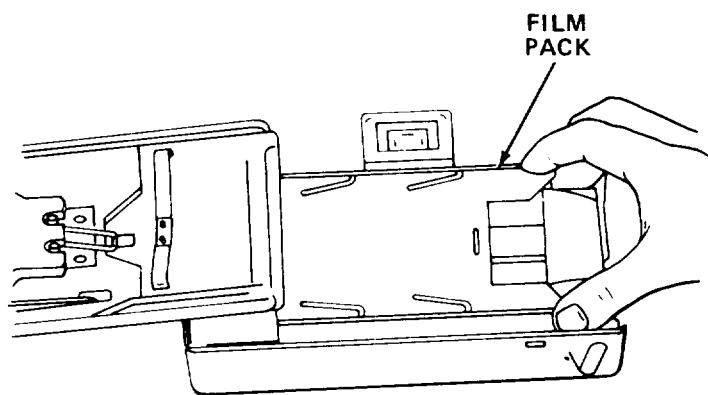

(c) Push film back down into camera. You will feel it snap into place.

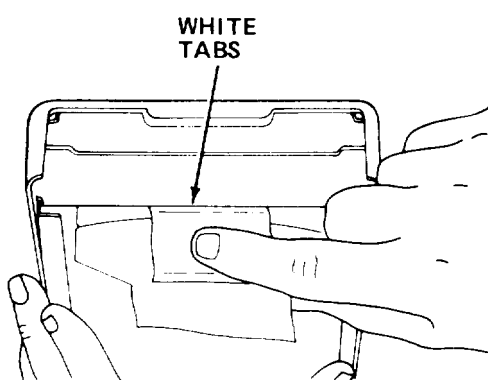

(d) Check that white tabs are free and not folded under. Close camera back door.

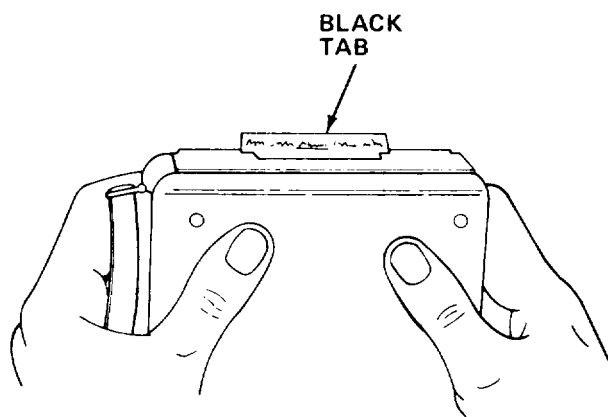

(e) Press both sides firmly to be sure that both sides latch. The black tab of safety cover must stick out of small slot. If not, reopen back and lead tab out.



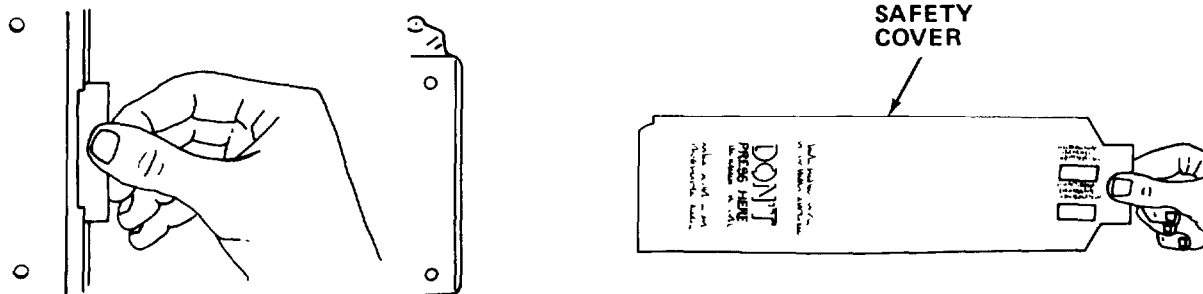

(f) Pull safety cover all the way out of camera without stopping. Do not rip it.

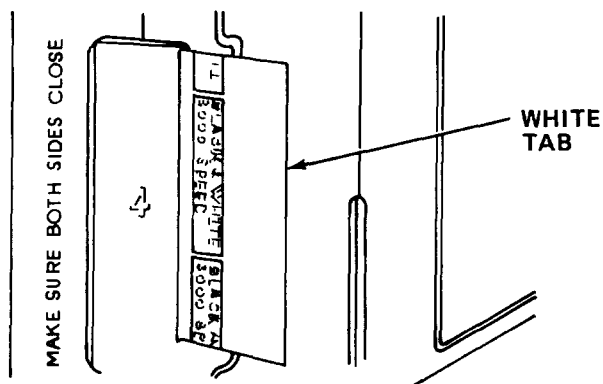

(g) With safety cover out, white tab should stick out of small slot (no. 4). Do not pull white tab. You are now ready for the first picture.

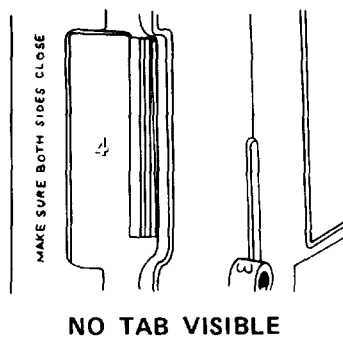

**NOTE**

If there is no white tab in the no. 3 slot, perform steps h. and i. in the shade or indoors; not in bright light.

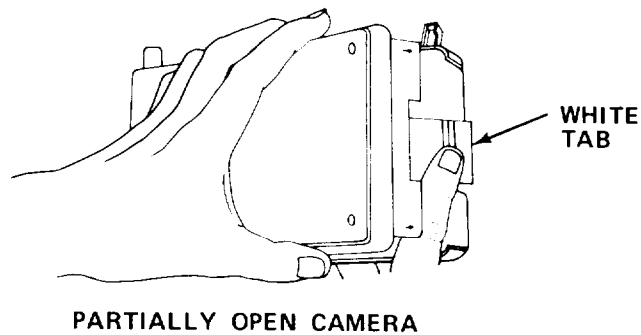

(h) Partially open back of camera and, without disturbing or moving film pack, push white tab out into the open.

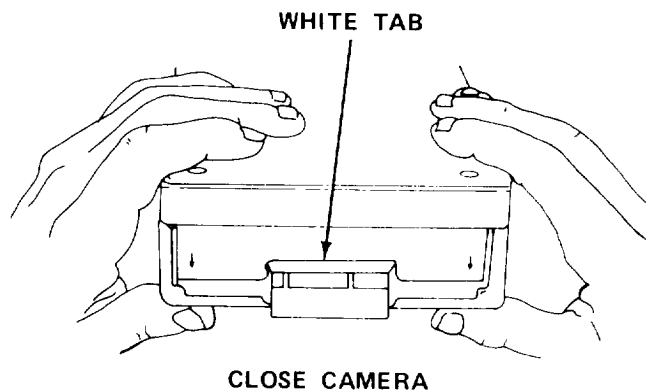

(i) Close back of camera, making sure that both sides are locked securely and white tab is outside in the no. 4 slot.

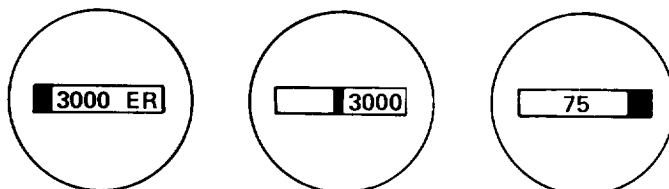
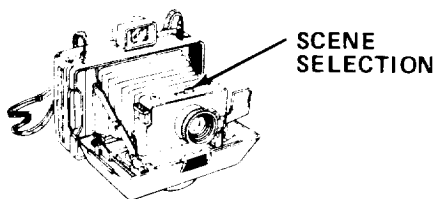

(j) Change scene selector setting by pushing lever to left or right. (For black and white film, 3000 (outdoor or flash) or 3000 ER (dim light); color, 75.)

**NOTE**

Use of flashcube will cause bright flash. Do not mount flashcube unless flash is required and expected.

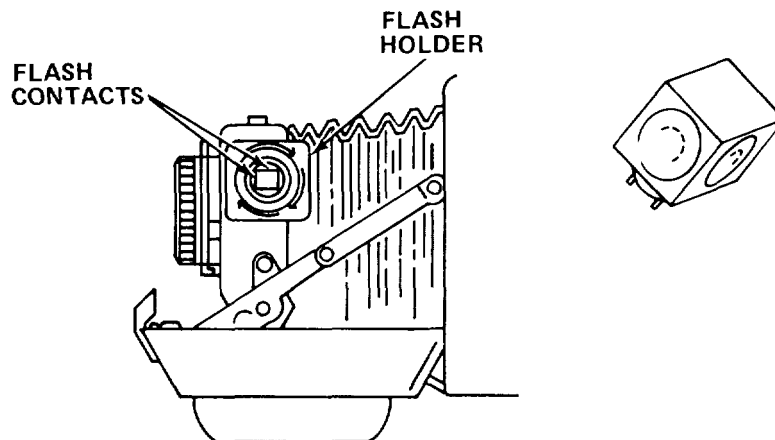

(k) Aline projection on flashcube with flash contacts and attach flashcube.

(l) Press into flash socket.

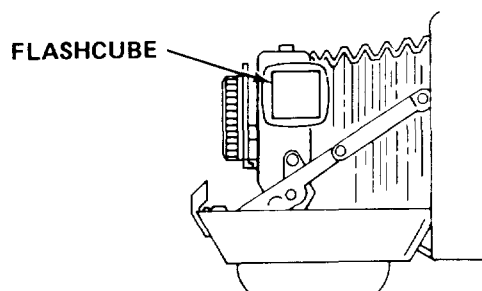

(m) Wind flashcube until a stop is felt.

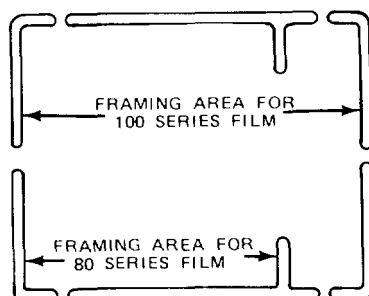

(n) Observe object in viewfinder and frame desired object in appropriate lines.

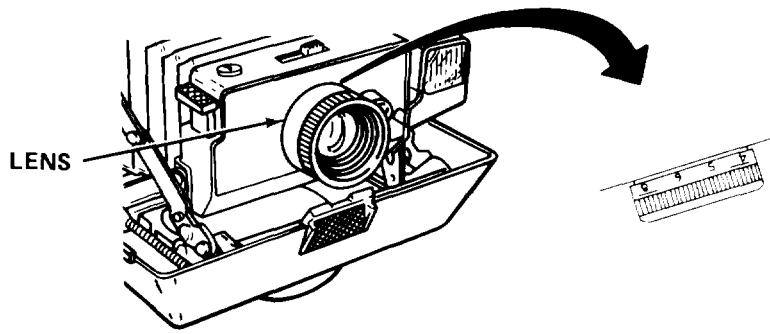

(o) Estimate range to object and set lens to estimated range in feet.

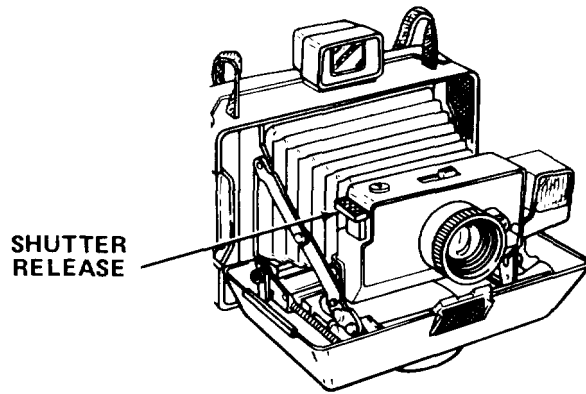

(p) Hold camera firmly with object framed in viewfinder. Press shutter release.

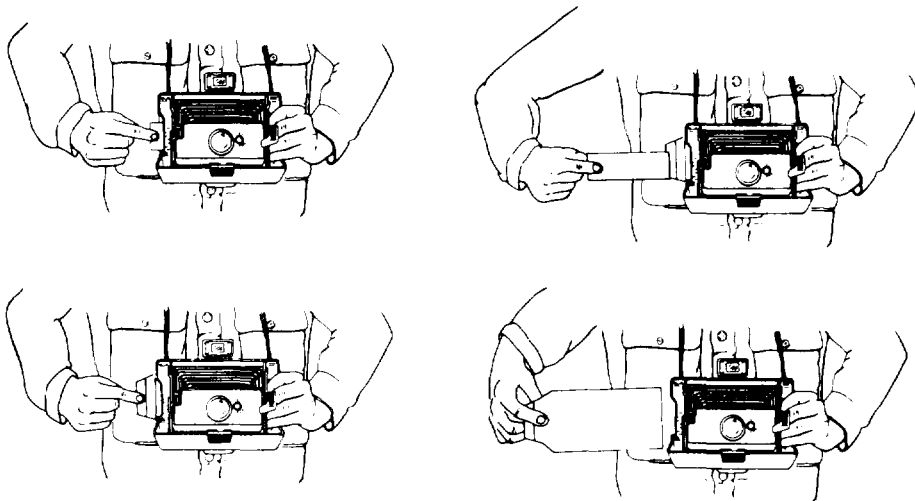

(q) Remove exposed print with a firm, steady pull.



(r) Wait 60 seconds before removing paper backing.

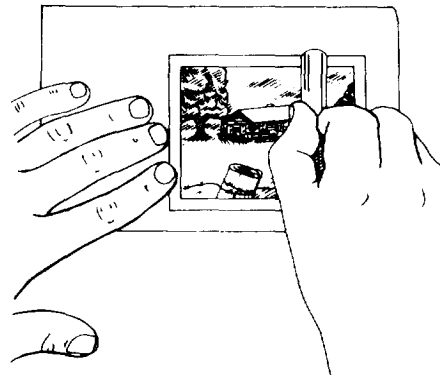

(s) Coat black and white prints.

### 9-6.3 Preparation for Movement.

a. Manual typewriter.

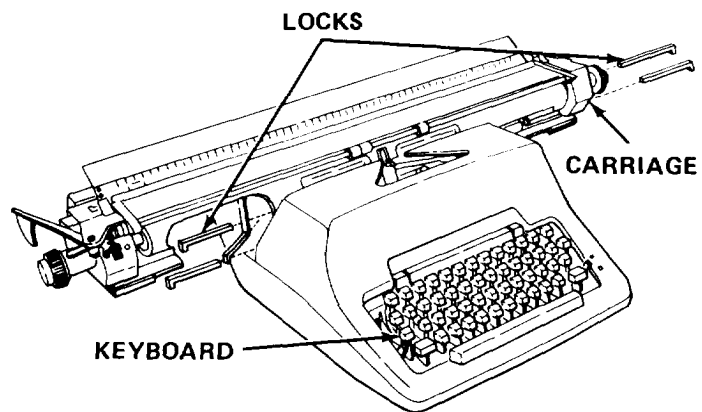

(1) Install locks on carriage.

(2) Replace dust cover.

9-6.4 Operating Instructions on Decals and Instruction Plates.

**WARNING**

THIS DEVICE IS NOT TO BE USED IN "HAZARDOUS LOCATIONS" AS DEFINED BY UNDERWRITERS LABORATORIES. IT SHOULD BE GROUNDED IN ACCORDANCE WITH PROVISIONS OF THE NATIONAL ELECTRIC CODE, OR ANY APPLICABLE LOCAL CODE, AND MAINTAINED IN ACCORDANCE WITH MANUFACTURER'S RECOMMENDATIONS.

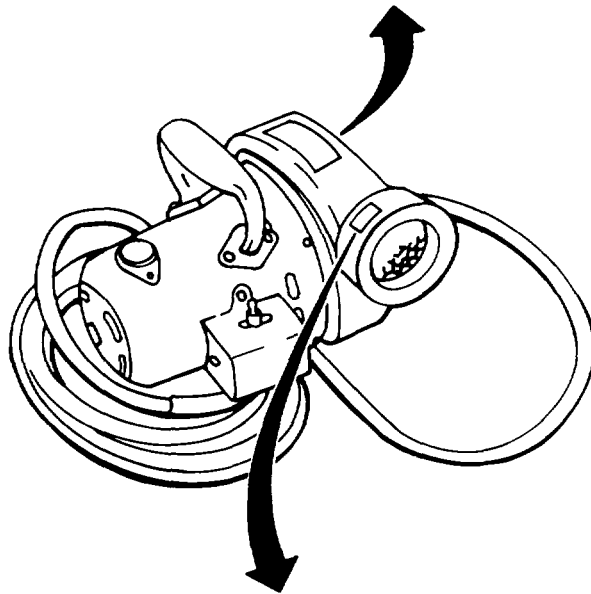

**WARNING!**

ELECTRIC SHOCK COULD OCCUR IF USED ON WET SURFACES. DO NOT EXPOSE TO RAIN. STORE INDOORS.

**9-7. OPERATION UNDER UNUSUAL CONDITIONS.**

**9-7.1 Still Picture (Instant) Camera Set.**

- a. Cold weather conditions: Under 65° F (18° C)

**NOTE**

Never use cold clip for black and white pictures. Instead, follow cold weather directions on instruction sheet packed with each box of film.

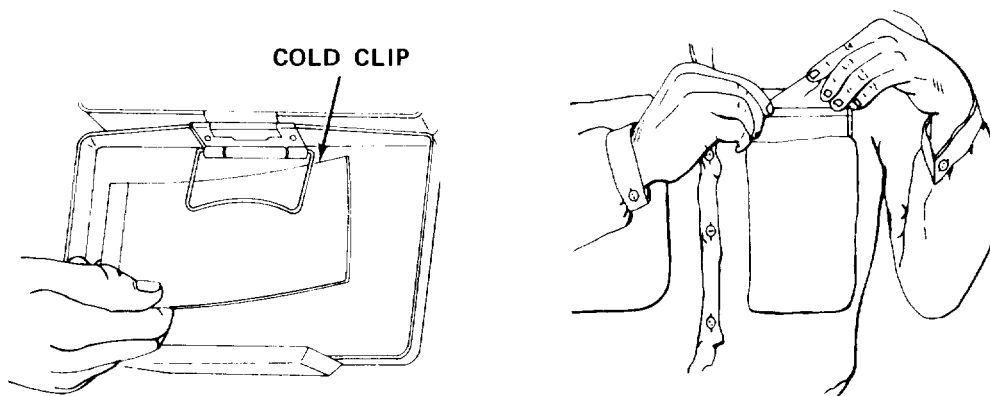

- (1) Remove cold clip from back of camera and warm by placing in an inner pocket.

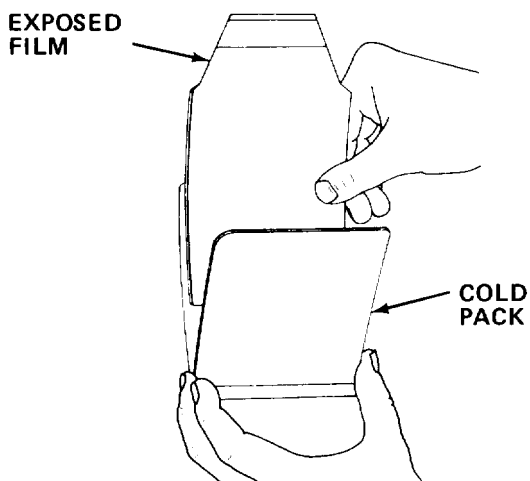

- (2) As soon as exposed film is removed from camera, place it in cold pack.

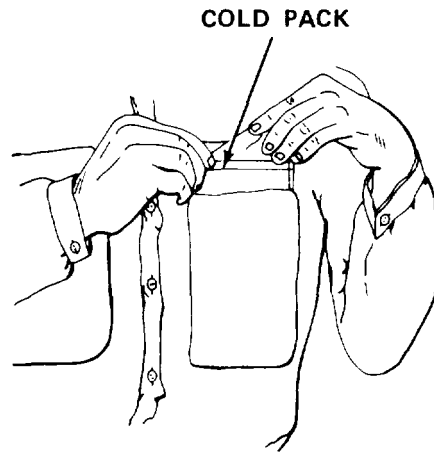

(3) Place cold pack next to body.

(4) After warming cold pack for 60 seconds, remove exposed film and separate picture.

(5) Allow additional time for black and white prints to develop.

#### NOTE

- Battery life will be shortened by low temperatures. Fresh batteries should be used in cold weather.
- Protect camera from sudden changes in temperature. Avoid going from heated spaces to cold spaces repeatedly with camera.

b. Hot weather conditions:

- (1) Do not leave camera in sun or closed vehicles.
- (2) Do not open film packs until ready to use.



### Section III OPERATOR MAINTENANCE

**9-8. LUBRICATION INSTRUCTIONS.** This equipment does not require lubrication.

**9-9. TROUBLESHOOTING PROCEDURES.**

a. The table lists the common malfunctions which you may find during operation or maintenance of the support equipment. You should perform the test/inspection and corrective actions in the order listed.

b. This manual cannot list all malfunctions that may occur, nor all test or inspection and corrective actions. If a malfunction is not listed or is not corrected by listed corrective actions, notify your supervisor.

**Table 9-2. TROUBLESHOOTING**

MALFUNCTION	TEST OR INSPECTION	CORRECTIVE ACTION
1. MAGNIFIER LAMP ASSEMBLY WILL NOT LIGHT.	Check that magnifier lamp assembly is plugged into active power outlet. Press switch OFF then ON.	<ul style="list-style-type: none"> <li>(a) If lamp still does not come on, replace lamp (paragraph 9-10.1).</li> <li>(b) If new lamp does not light, refer to organizational maintenance.</li> </ul>
2. VACUUM CLEANER MOTOR DOES NOT OPERATE.	<p>Step 1. Check power cord.</p> <ul style="list-style-type: none"> <li>(a) If plugged in, proceed to step 2.</li> <li>(b) Plug in power cord.</li> </ul> <p>Step 2. Check position of power switch.</p> <ul style="list-style-type: none"> <li>(a) If turned on, proceed to step 3.</li> <li>(b) Turn power switch on.</li> </ul> <p>Step 3. Check circuit breaker position in circuit breaker box.</p> <ul style="list-style-type: none"> <li>(a) If turned off or tripped, turn circuit breaker on.</li> </ul>	

**Table 9-2. TROUBLESHOOTING - Cont**

---

MALFUNCTION

TEST OR INSPECTION

CORRECTIVE ACTION

---

**2. VACUUM CLEANER MOTOR DOES NOT OPERATE - Cont**

(b) If turned on refer to organizational maintenance.

**3. PSYCHROMETER LAMP WILL NOT LIGHT.**

Check that switch is ON.

(a) Replace lamp (paragraph 9-10.3).

(b) If lamp still does not light, replace batteries (paragraph 9-10.2).

(c) If lamp still does not light, replace psychrometer.

**4. FAN WILL NOT OPERATE IN PSYCHROMETER.**

Check that switch is ON.

(a) If fan does not work, replace batteries (paragraph 9-10.2).

(b) If fan still does not work, replace psychrometer.

**5. FLASHCUBE WILL NOT INDEX FOR ALL FOUR FLASHES.**

Step 1. Turn flashcube. Cube turns easily.

(a) If flashcube turns easily, proceed to step 2.

(b) Wind flashcube to limit.

Step 2. Inspect flashcube holder for dirt.

Clean holder.

**Table 9-2. TROUBLESHOOTING - Cont**

---

MALFUNCTION	TEST OR INSPECTION	CORRECTIVE ACTION
-------------	--------------------	-------------------

---

<b>6. FLASHCUBE WILL NOT FIRE.</b>		
	Inspect for loose battery latch.	
	(a) Latch battery firmly.	
	(b) Replace batteries.	
	(c) Replace flashcube.	
<b>7. BATTERIES DRAINING (UNUSUAL IN 6 MONTHS OR LESS).</b>		
	Inspect for corrosion on batteries.	
	(a) Clean battery contacts.	
	(b) Replace batteries.	
	(c) Replace camera.	
<b>8. SHUTTER NOT OPERATING.</b>		
	Test shutter.	
	(a) Replace batteries.	
	(b) Replace camera.	
<b>9. PICTURE TOO DARK OR TOO LIGHT.</b>		
	Step 1. Check film speed selector.	
	(a) If film speed selector is correct, proceed to step 2.	
	(b) Correct film speed setting.	
	Step 2. Check that photoelectric cell lens is clean.	
	(a) If photoelectric cell lens is clean, proceed to step 3.	
	(b) Clean photoelectric cell lens.	

**Table 9-2. TROUBLESHOOTING - Cont**

---

MALFUNCTION

TEST OR INSPECTION

CORRECTIVE ACTION

---

**9. PICTURE TOO DARK OR TOO LIGHT - Cont**

Step 3. Check that main lens is clean.

- (a) Clean lens.
- (b) Replace batteries.
- (c) Replace camera.

**10. PICTURE NOT SHARP.**

Step 1. Check that camera lenses are clean.

- (a) If lenses are clean, proceed to step 2.
- (b) Clean lenses.

Step 2. Check that camera focuses properly.

- (a) Correct focus.
- (b) Replace camera.

**11. POOR SPREAD IN DEVELOPING.**

Step 1. Inspect for dirt on rollers.

- (a) If rollers are clean, proceed to step 2.
- (b) Clean rollers.

Step 2. Inspect for dirt on exit door.

Clean door.

---

**9-10. MAINTENANCE PROCEDURES.**

a. This section contains instructions covering operator maintenance functions for the support items. Personnel required are listed only if the task requires more than one.

b. After completing each maintenance procedure, perform operational check to be sure that equipment is properly functioning.

INDEX

PROCEDURE	PARAGRAPH
Replace Lamp in Magnifier Lamp Assembly . . . . .	9-10.1
Replace Batteries in Hand Psychrometer . . . . .	9-10.2
Replace Lamp in Hand Psychrometer . . . . .	9-10.3
Replace Wick in Hand Psychrometer . . . . .	9-10.4
Replace Thermometers in Hand Psychrometer . . . . .	9-10.5
Replace Pith Ball in Air Velocity Meter . . . . .	9-10.6
Replace Batteries in Still Picture (Instant) Camera Set . . . . .	9-10.7

9-10.1 Replace Lamp in Magnifier Lamp Assembly.

MOS: 81Q, Terrain Analyst

SUPPLIES: Fluorescent Lamp (22 W)

**WARNING**

Death or serious injury may occur from electrical shock unless power cord is unplugged before servicing.

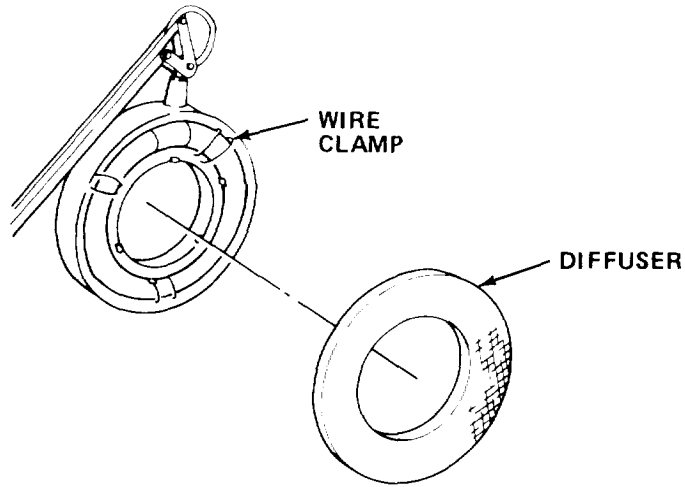

- a. Unplug magnifier lamp assembly and remove diffuser.

**NOTE**

On some magnifier lamp models, tube is held in place with friction clamps.

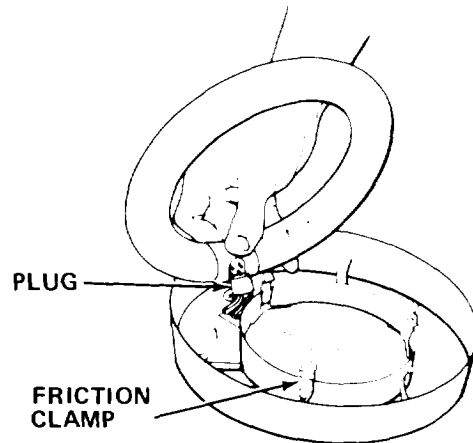

- b. Release wire clamps, pull out lamp, and disconnect plug from lamp.
- c. Connect plug to new lamp and retain lamp with wire clamps.
- d. Reinstall diffuser.

9-10.2 Replace Batteries in Hand Psychrometer.

MOS: 81Q, Terrain Analyst

SUPPLIES: Three Batteries (D-size, 1.5 V)

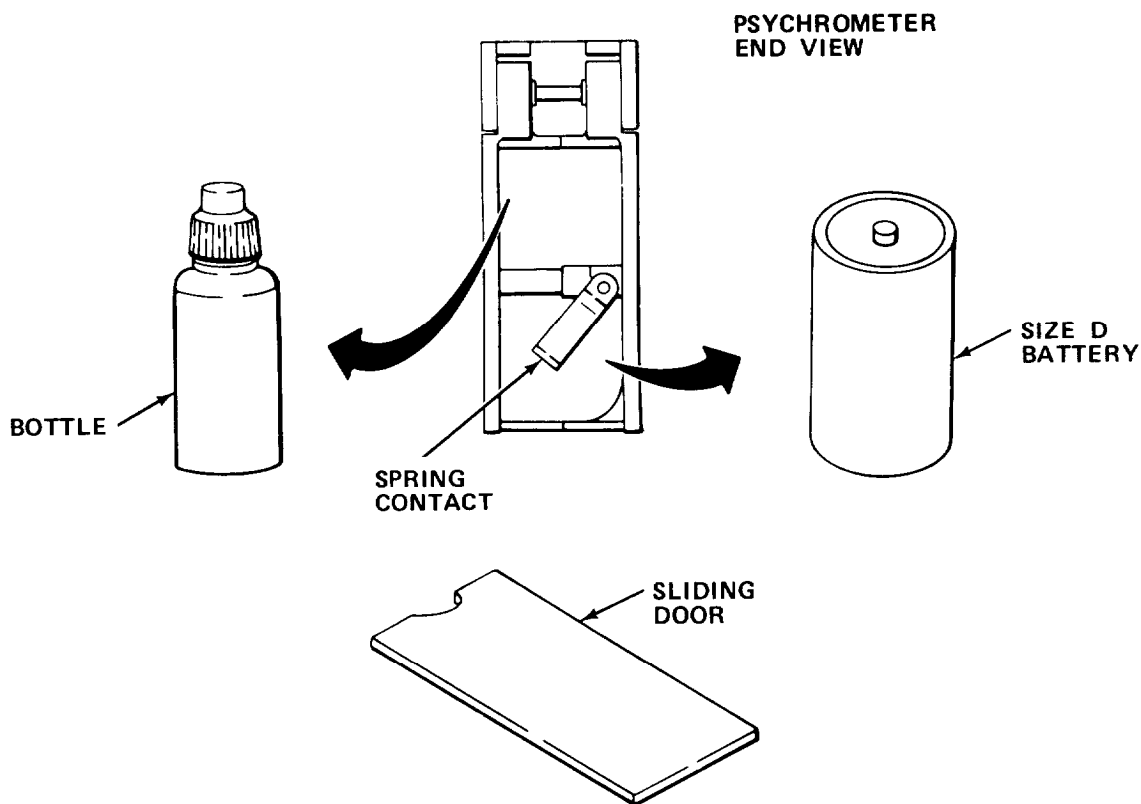

- a. Remove sliding door from end of hand psychrometer.
- b. Rotate spring contact from battery compartment to bottle compartment and remove batteries.

**CAUTION**

Keep hand psychrometer as close to horizontal as possible to prevent distortion of battery contact at far end of battery compartment. Insert center contact post of battery first.

- c. Insert three D-size batteries into battery compartment.
- d. Rotate spring contact to its original position and replace sliding door.

9-10.3 Replace Lamp in Hand Psychrometer.

MOS: 81Q, Terrain Analyst

TOOLS: Cross Tip Screwdriver

SUPPLIES: Lamp (GE-47)

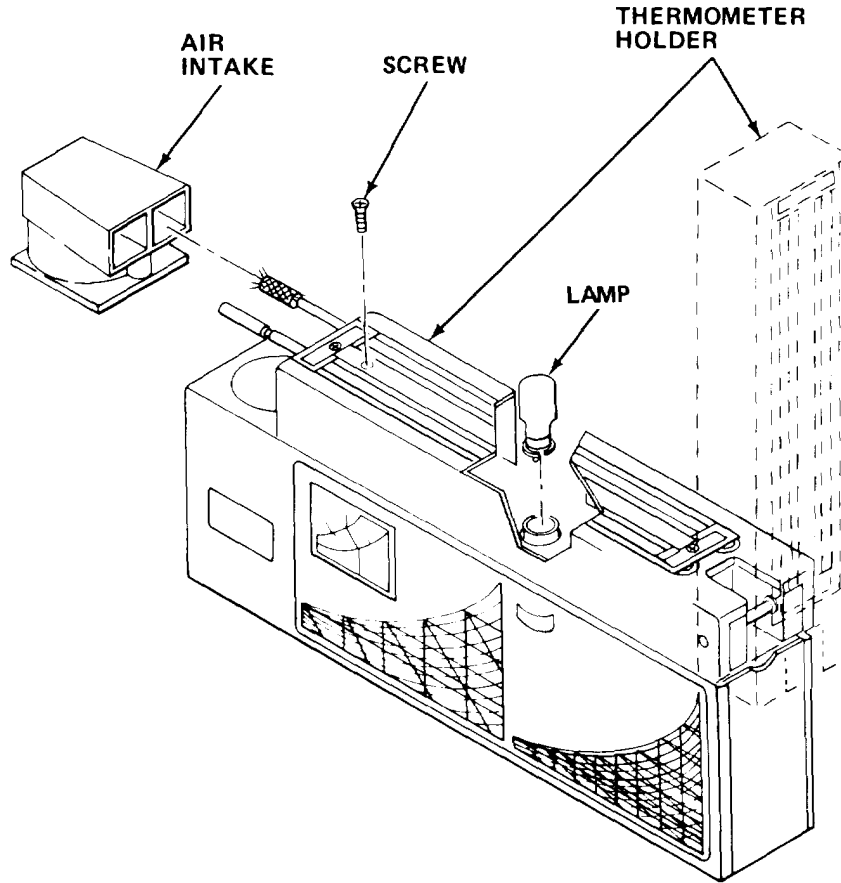

- a. Remove air intake.
- b. Remove screw securing thermometer holder.
- c. Raise holder upward to gain access to lamp.
- d. Replace defective lamp.
- e. Lower holder.
- f. Secure holder in place with screw.
- g. Replace air intake.



#### 9-10.4 Replace Wick in Hand Psychrometer.

MOS: 81Q, Terrain Analyst

SUPPLIES: Wick  
Thread

- a. Remove air intake. Remove and discard old wick.
- b. Clean thermometer bulb.
- c. Install new wick and tie with thread at narrow section between bulb and thermometer stem.
- d. Stretch wick toward end of bulb. Tie wick at end of bulb with second thread, trim threads, and trim wick about 1/8 in. (3 mm) from end of bulb.
- e. Reinstall air intake.

#### 9-10.5 Replace Thermometers in Hand Psychrometer.

MOS: 81Q, Terrain Analyst

TOOLS: Cross Tip Screwdriver

SUPPLIES: Thermometer Set

- a. Remove air intake and two retainer strips holding the thermometer in position.
- b. Lift out defective thermometers and remove the rubber bushings.

#### **NOTE**

These thermometers are supplied as a matched set. Do not replace separately.

- c. Install rubber bushings on new thermometers, position thermometers on psychrometer, and secure with retainer strips and screws.
- d. Reinstall air intake.

9-10.6 Replace Pith Ball in Air Velocity Meter.

MOS: 81Q, Terrain Analyst

SUPPLIES: Pith Ball

**CAUTION**

Avoid handling pith ball. If handling is essential, then do so gently to avoid damage.

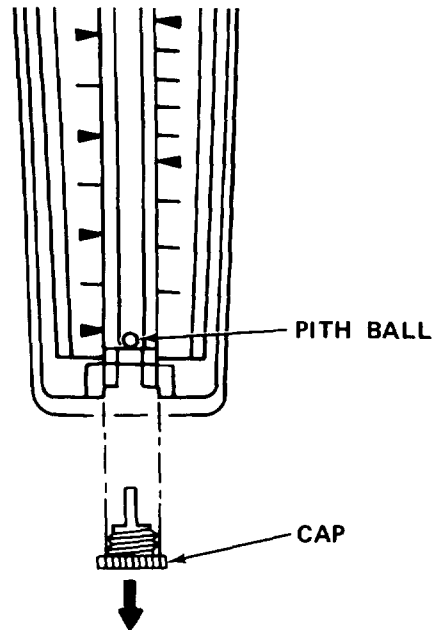

- a. Remove cap from indicator tube.
- b. Allow damaged pith ball to fall out of tube.
- c. Remove spare pith ball from packet in plastic case.
- d. Place new pith ball into indicator tube.
- e. Replace and tighten cap.

9-10.7 Replace Batteries in Still Picture [Instant) Camera Set.

MOS: 81Q, Terrain Analyst

SUPPLIES: Two Batteries (Size AA 1.5 V)

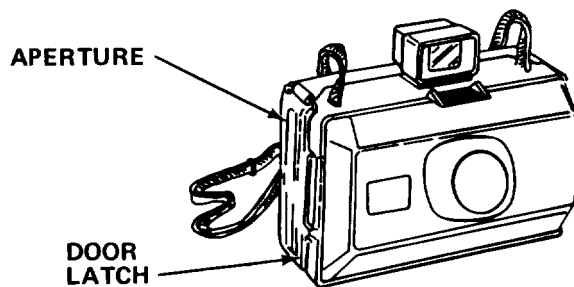

- a. Inspect camera door aperture to confirm camera is not loaded with film pack.
- b. Release door latch and open camera door.

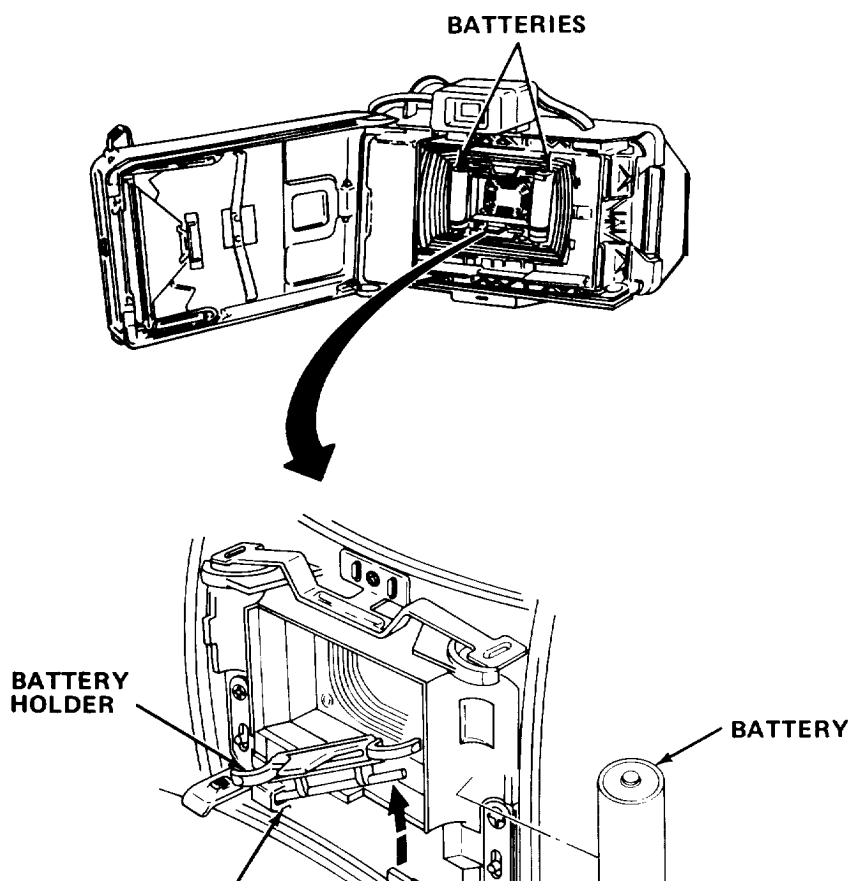

- c. Lift right end of battery holder and slide holder from retainer on left.
- d. Note position of each battery (positive or negative end up) and pull batteries out of holder with fingers.
- e. Place fresh batteries in same positions as old batteries.
- f. Reinstall battery holder by sliding left edge in slot and then pushing right end down.
- g. Cover photoelectric cell lens with finger or cloth.
- h. Set scene selector to 75.
- i. Press shutter button and observe that shutter opens.
- j. Uncover photoelectric cell lens. Observe shutter closes.
- k. Close camera door and latch.

## Section IV ORGANIZATIONAL MAINTENANCE

**9-11. LUBRICATION INSTRUCTIONS.** This equipment does not require lubrication.

**9-12. REPAIR PARTS, SPECIAL TOOLS, TEST, MEASUREMENT, AND DIAGNOSTIC EQUIPMENT (TMDE); AND SUPPORT-EQUIPMENT.**

9-12.1 Common Tools and Equipment. For authorized common tools and equipment refer to the Modified Table of Organization and Equipment (MTOE) applicable to your unit.

9-12.2 Special Tools; Test, Measurement, and Diagnostic Equipment; and Support Equipment; Special Tools, TMDE, and Support Equipment is listed in the applicable repair parts and special tools list and in Appendix B of this manual.

9-12.3 Repair Parts. Repair parts are listed and illustrated in the Repair Parts and Special Tools List, TM 5-6675-322-24P covering organizational maintenance for this equipment.

**9-13. SERVICE UPON RECEIPT.**

9-13.1 Checking Unpacked Equipment.

a. Inspect the equipment for damage incurred during shipment. If equipment has been damaged, report the damage on DD Form 6, Packing Improvement Report.

b. Check the equipment against the packing list to see if the shipment is complete. Report all discrepancies in accordance with the instructions of DA Pam 738-750.

c. Check to see whether the equipment has been modified.

**9-14. ORGANIZATIONAL PREVENTIVE MAINTENANCE CHECKS AND SERVICES.** There are no organizational PMCS procedures assigned for this equipment.

**9-15. ORGANIZATIONAL TROUBLESHOOTING PROCEDURES.**

a. Organizational troubleshooting procedures cover the most common malfunctions that may be repaired at the organizational level. Repair or adjustment requiring specialized equipment is not authorized unless such equipment is available. Troubleshooting procedures used by lower level maintenance should be conducted in addition to the organizational troubleshooting procedures.

b. This manual cannot list all the possible malfunctions or every possible test/inspection and corrective action. If a malfunction is not listed or corrected by a listed corrective action, notify your supervisor.

c. If the support item does not power up when turned on, verify that 120 V ac is present at the receptacle. If voltage is not present, plug equipment into receptacle with power available and proceed with equipment troubleshooting. Perform no-power procedure for dead receptacle (Table 1-4).

**Table 9-3. ORGANIZATIONAL TROUBLESHOOTING**

---

MALFUNCTION
TEST OR INSPECTION
CORRECTIVE ACTION

---

**WARNING**

Death or serious injury may occur from electrical shock unless power cord is unplugged before servicing.

**1. VACUUM CLEANER MOTOR DOES NOT OPERATE.**

Check that the vacuum cleaner is plugged into active outlet. Turn switch on.

If motor does not operate, replace vacuum cleaner.

**2. MAGNIFIER LAMP WILL NOT LIGHT.**

Check that magnifier lamp is plugged into active power outlet. Press switch off then on.

Replace magnifier lamp assembly (paragraph 9-16.1).

**9-16. MAINTENANCE PROCEDURES.**

a. This section contains instructions covering organizational maintenance functions for the support items. Personnel required are listed only if the task requires more than one.

b. After completing each maintenance procedure, perform operational check to be sure that equipment is properly functioning.

**INDEX**

PROCEDURE	PARAGRAPH
Replace Magnifier Lamp Assembly . . . . .	9-16.1
Remove/Install Manual Typewriter . . . . .	9-16.2

9-16.1 Replace Magnifier Lamp Assembly.

MOS: 41B, Topographic Instrument Repair Specialist

TOOLS: Flat Tip Screwdriver

SUPPLIES: Magnifier Lamp Assembly

**WARNING**

Death or serious injury may occur from electrical shock if power cord is not unplugged before servicing.

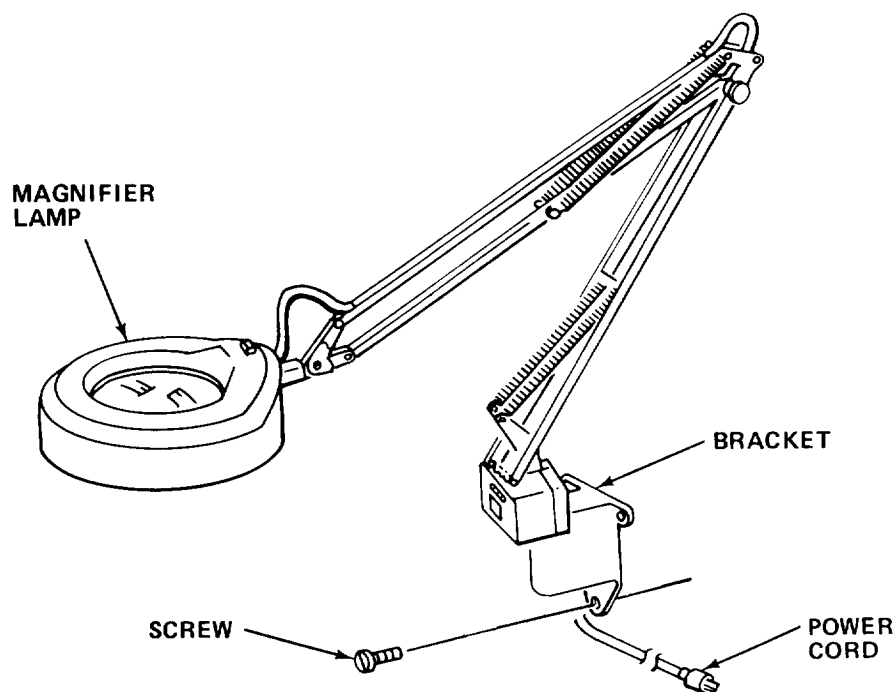

- a. Unplug power cord and remove magnifier lamp assembly from bracket.
- b. Remove screws to release bracket from wall.
- c. Install new bracket and secure with screws.
- d. Install new magnifier lamp assembly on bracket and plug in power cord.

9-16.2 Replace Manual Typewriter.

MOS: 41B, Topographic Instrument Repair Specialist

TOOLS: Flat Tip Screwdriver  
8 in. Adjustable Wrench

SUPPLIES: Typewriter

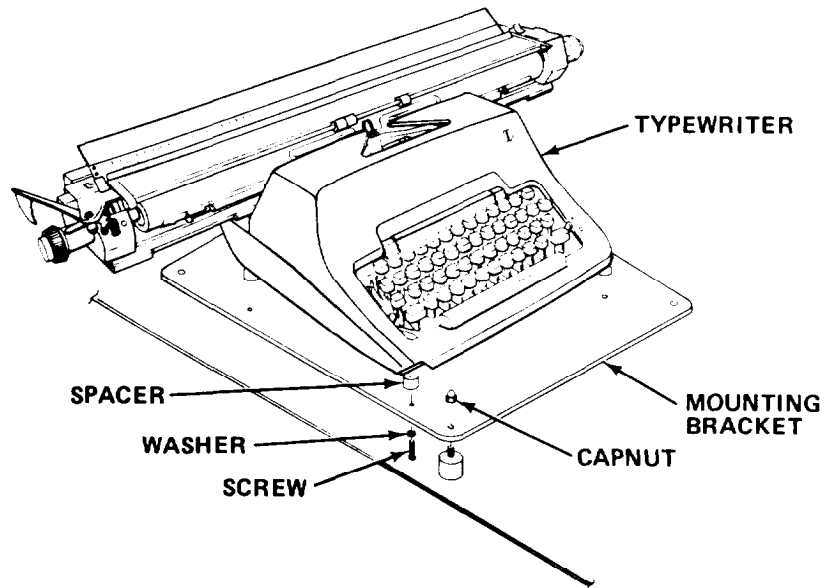

- a. Remove capnuts from mounting bracket.
- b. Remove typewriter and mounting bracket.
- c. Remove screws, washers, and spacers securing typewriter to mounting bracket.
- d. Remove defective typewriter.
- e. Secure new typewriter to mounting bracket with spacers, washers, and screws.
- f. Install new typewriter and bracket.
- g. Secure mounting bracket with capnuts.

**9-17. PREPARATION FOR STORAGE OR SHIPMENT.** Contact your battalion for packing and shipping instructions.

**Section V DIRECT/GENERAL SUPPORT MAINTENANCE**

There are no direct/general support maintenance procedures assigned for this equipment.



**APPENDIX A**

**REFERENCES**

**A-1. SCOPE.**

This appendix lists all forms, field manuals, technical manuals and miscellaneous publications referenced in this manual.

**A-2. FORMS.**

Recommended Changes to Publications and Blank Forms . . . . . DA Form 2028

Recommended Changes to Equipment Technical Publications . . . . . DA Form 2028-2

Equipment Inspection and Maintenance Worksheet . . . . . DA Form 2404

The Army Maintenance Management System (TAMMS). . . . . DA Pam 738-750

Quality Deficiency Report. . . . .SF 368

**A-3. FIELD MANUALS.**

Camouflage. . . . . FM 5-20

Nuclear, Biological and Chemical (NBC)  
 Defense (Reprintedw/Basic Incl C1) . . . . .FM 21-40

Basic Cold Weather Manual. . . . . FM 31-70

Northern Operations. . . . . FM 31-71

Metal Body Repair and Related Operations . . . . . FM 43-2

First Aid for Soldiers. . . . . FM 21-11

**A-4 . TECHNICAL MANUALS.**

Administrative Storage of Equipment . . . . . TM 740-90-1

Chemical, Biological and Radiological (CBR)  
 Decontamination. . . . . TM 3-220

Operator, Organizational, Direct Support and General  
 Support Maintenance Manual: Air Conditioner, Horizontal,  
 Compact, 208-Volt, 3-Phase, 18,000 Btu Cooling, 12,000  
 Btu Heating. . . . . TM 5-4120-367-14

Operator, Organizational, Direct Support and  
 General Support Maintenance Manual for Chassis,  
 Semi-Trailer, Container Transporter (ADCOR) . . . . . TM 5-2330-305-14

**TM 5-6675-322-14**

- Organizational , Direct Support and General Support  
Maintenance Repair Parts and Special Tools List  
(Including Depot Maintenance Repair Parts and  
Special Tools) for Air Conditioner/Heater . . . . . TM 5-4120-367-24P
  
- Organizational , Direct Support and General Support  
Maintenance Repair Parts and Special Tools List  
(Including Depot Maintenance Repair Parts and  
Special Tools) for Chassis, Semi-Trailer,  
Container Transporter (ADCOR) . . . . . TM 5-2330-305-24P
  
- Organizational , Direct Support and General Support  
Maintenance Repair Parts and Special Tools List  
(RPSTL) (Including Depot Maintenance Repair Parts  
and Special Tools) for Collection Section . . . . . TM 5-6675-322-24P
  
- Operator Maintenance Manual for Camera Set,  
Still Picture, Camera Model KS99C . . . . . TM 11-6720-253-10
  
- Organizational , Direct Support and General Support  
Maintenance Manual (Including Repair Parts and  
Special Tools) for Camera Set, Still Picture,  
Camera Model KS99C . . . . . TM 11-6720-253-24P
  
- Operator, Organizational, Direct Support, General  
Support, and Field Maintenance Facsimile Transceiver  
AN/GXC-7A . . . . . TM 11-5895-1079-14
  
- Painting Instructions for Field Use . . . . . TM 43-0139
  
- Procedure for the Destruction of Equipment to  
Prevent Enemy Use. . . . . TM 750-244-3
  
- Use and Care of Hand Tools and Measuring Tools . . . . . TM 9-243

**A-5. MISCELLANEOUS PUBLICATIONS.**

- Lubrication Order: Topographic Support System  
Collection Section, Model ADC-TSS-11 . . . . . LO 5-6675-322-12
  
- Lubrication Order: Topographic Support System  
Chassis, Semi-Trailer, Container Transporter (ADCOR) . . . . . LO 5-2330-305-12

**APPENDIX B****MAINTENANCE ALLOCATION CHART****Section I INTRODUCTION****B-1. GENERAL.**

a. This section provides a general explanation of all maintenance and repair functions authorized at various maintenance categories.

b. The Maintenance Allocation Chart (MAC) in Section II designates overall responsibility for the performance of maintenance functions on the identified end item or component. The application of the maintenance functions to the end item or component will be consistent with the capacities and capabilities of the designated maintenance categories.

c. Section III lists the tools and test equipment (both special tools and common tool sets) required for each maintenance function as referenced from Section II.

d. Section IV contains supplemental instructions and explanatory notes for a particular maintenance function.

**B-2. MAINTENANCE FUNCTIONS.** Maintenance functions will be limited to and defined as follows:

a. **Inspect.** To determine the serviceability of an item by comparing its physical, mechanical and/or electrical characteristics with established standards through examination (e.g., by sight, sound, or feel).

b. **Test.** To verify serviceability by measuring the mechanical, pneumatic, hydraulic or electrical characteristics of an item and comparing those characteristics with prescribed standards.

c. **Service.** Operations required periodically to keep an item in proper operating condition, i.e., to clean (includes decontaminate, when required), to preserve, to drain, to paint, or to replenish fuel, lubricants, chemical fluids, or gases.

d. **Adjust.** To maintain or regulate, within prescribed limits, by bringing into proper or exact position, or by setting the operating characteristics to specified parameters.

e. **Aline.** To adjust specified variable elements of an item to bring about optimum or desired performance.

f. **Calibrate.** To determine and cause corrections to be made or to be adjusted on instruments or test, measuring and diagnostic equipment used in precision measurement. Consists of comparisons of two instruments, one of which is a certified standard of known accuracy, to detect and adjust any discrepancy in the accuracy of the instrument being compared.

g. Remove/Install. To remove and install the same item when required to perform service or other maintenance functions. Install may be the act of emplacing, seating, or fixing into position a spare, repair part, or module (component or assembly) in a manner to allow the proper functioning of an equipment or system.

h. Replace. To remove an unserviceable item and install a serviceable counterpart in its place. "Replace" is authorized by the MAC and is shown as the 3d position code of the SMR code.

i. Repair. The application of maintenance services<sup>1</sup>, including fault location/-troubleshooting<sup>2</sup>, removal/installation, and disassembly/assembly<sup>3</sup> procedures, and maintenance actions<sup>4</sup> to identify troubles and restore serviceability to an item by correcting specific damage, fault, malfunction, or failure in a part, subassembly, module (component or assembly), end item or system.

j. Overhaul. That maintenance effort (service/action) prescribed to restore an item to a completely serviceable/operational condition as required by maintenance standards in appropriate technical publications (i.e., DMWR). Overhaul is normally the highest degree of maintenance performed by the Army. Overhaul does not normally return an item to like new condition.

k. Rebuild. Consists of those services/actions necessary for the restoration of unserviceable equipment to a like new condition in accordance with original manufacturing standards. Rebuild is the highest degree of material maintenance applied to Army equipment. The rebuild operation includes the act of returning to zero those age measurements (hours/miles, etc.) considered in classifying Army equipment/components.

### **B-3. EXPLANATION OF COLUMNS IN THE MAC, SECTION II**

a. Column 1, Group Number. Column 1 lists functional group code numbers, the purpose of which is to identify maintenance significant components, assemblies, subassemblies and modules with the next higher assembly. End item group number shall be "00."

b. Column 2, Component/Assembly. Column 2 contains the names of components, assemblies, subassemblies, and modules for which maintenance is authorized.

c. Column 3, Maintenance Function. Column 3 lists the functions to be performed on the item listed in Column 2. (For detailed explanation of these functions, see paragraph B-2.)

---

<sup>1</sup>Services - Inspect, test, service, adjust, aline, calibrate and/or replace.

<sup>2</sup>Fault locate/troubleshoot - The process of investigating and detecting the cause of equipment malfunctioning; the act of isolating a fault within a system or unit under test (UUT).

<sup>3</sup>Disassemble/assemble - Encompasses the step-by-step taking apart (or breakdown) of a spare/functional group coded item to the level of its least componency identified as maintenance significant (i.e., assigned an SMR code) for the category of maintenance under consideration.

<sup>4</sup>Actions - Welding, grinding, riveting, straightening, facing, remachining and/or resurfacing.

d. Column 4, Maintenance Category. Column 4 specifies, by the listing of a work time figure in the appropriate subcolumn(s), the category of maintenance authorized to perform the function listed in Column 3. This figure represents the active time required to perform that maintenance function at the indicated category of maintenance. If the number or complexity of the tasks within the listed maintenance function varies at different maintenance categories, appropriate work time figures will be shown for each category. The work time figure represents the average time required to restore an item (assembly, subassembly, component, module, end item or system) to a serviceable condition under typical field operation conditions. This time includes preparation time (including any necessary disassembly/assembly time), troubleshooting/fault location time, and quality assurance/quality control time in addition to the time required to perform the specific tasks identified for the maintenance functions authorized in the Maintenance Allocation Chart. The symbol designations for the various maintenance categories are as follows:

- C . . . . Operator or Crew
- O . . . . Organizational Maintenance
- F . . . . Direct Support Maintenance
- H . . . . General Support Maintenance
- L . . . . Specialized Repair Activity <sup>5</sup>
- D . . . . Depot Maintenance

e. Column 5, Tools and Equipment. Column 5 specifies, by code, those common tool sets (not individual tools) and special tools, TMDE and support equipment required to perform the designated function.

f. Column 6, Remarks. This column shall, when applicable, contain a letter code in alphabetical order, which shall be keyed to the remarks contained in Section IV.

---

<sup>5</sup>This maintenance category is not included in Section II, column (4) of the Maintenance Allocation Chart. To identify functions to this category of maintenance, enter a work time figure in the "H" column of Section II, column (4), and use an associated reference code in the Remarks column (6). Key the code to Section IV, Remarks, and explain the SRA complete repair application there. The explanatory remark(s) shall reference the specific Repair Parts and Special Tools List (RPSTL) TM which contains additional SRA criteria and the authorized spare/repair parts.

**B-4. EXPLANATION OF COLUMNS IN TOOL AND TEST EQUIPMENT REQUIREMENTS, SECTION III**

- a. Column 1, Reference Code. The tool and test equipment reference code correlates with a code used in the MAC, Section II, Column 5.
- b. Column 2, Maintenance Category. The lowest category of maintenance authorized to use the tool or test equipment.
- c. Column 3, Nomenclature. Name or identification of the tool or test equipment.
- d. Column 4, National Stock Number. The National stock number of the tool or test equipment.
- e. Column 5, Tool Number. The manufacturer's part number.

**B-5. EXPLANATION OF COLUMNS IN REMARKS, SECTION IV**

- a. Column 1, Reference Code, The code recorded in Column 6, Section II.
- b. Column 2, Remarks. This column lists information pertinent to the maintenance function being performed as indicated in the MAC, Section II.

Section II. MAINTENANCE ALLOCATION CHART - Cont

(1) Group Number	(2) Component/Assembly	(3) Maintenance Function	(4) Maintenance Cat					(5) Tools and Eqpt	(6) Remarks
			C	O	F	H	D		
00	COLLECTION SECTION	Overhaul							
01	VAN BODY (ISO CONTAINER)	Inspect	0.8						
		Service	0.9	0.5				5,7,10,13	D
		Repair		1.0	1.5	2.0		1,3,4	
	FLUORESCENT LIGHT ASSY.	Repair	0.1	0.7				1	
	BLACKOUT/DOME LIGHT ASSY.	Repair	0.2						
	EXHAUST FAN ASSEMBLY	Repair		0.5					
	AIR CONDITIONER/ HEATER ASSY.	Replace				2.0		1	B
	ELECTRICAL ASSEMBLY	Inspect		0.5				1	
		Repair		0.9	1.0			1,3	
	TELEPHONE BINDING POST ASSY.	Repair		0.7				1	
	EMERGENCY LIGHT ASSY.	Replace		0.3				1	
	TIEDOWN SOCKET ASSY.	Replace		0.3				4	
	LEVEL INDICATOR ASSY.	Repair		0.6				2,4	
	BLACKOUT CURTAIN ASSY.	Repair		1,0				4	
	PERSONNEL LADDER ASSY.	Repair		0.8				4,14	D
	PERSONNEL/CARGO DOOR ASSY.	Replace			1.5			4	
		Repair			2.0			4	

\* \* Depot will determine work times

Section II. MAINTENANCE ALLOCATION CHART - Cont

(1) Group Number	(2) Component/Assembly	(3) Maintenance Function	(4) Maintenance Cat.					(5) Tools and Eqpt	(6) Remarks	
			C	O	F	H	D			
02	DRAFTING, SCRIBING TRACING TABLE	Inspect	0.2							
		Service	0.4					11		
		Remove/ Install			1.0			1		
	ELECTRICAL SYSTEM	Repair	0.2	0.6				1		
	TABLE TOP TILT LOCKING ASSEMBLY	Repair		0.7				1		
	PILLOW BLOCK ASSEMBLY	Replace		0.5				1		
03	POCKET CALCULATOR	Inspect	0.3							
04	STEREOMETER PARALLAX BAR	Inspect	0.3							
		Service	0.3					7		
05	LENS-PRISM-MIRROR STEREOSCOPE	Inspect	0.2							
		Service	0.3					8		
		Adjust	0.2					9		
06	ULTRASONIC CLEANER	Inspect	0.2					1		
		Repair		0.7				1		
	CIRCUIT BOARD	Replace		0.6				1	A	
07	FACSIMILE TRANSCEIVER								C	
08	FURNITURE AND CABINETS	Inspect	0.5							
		Remove/ Install		0.9					1,3,4,14	D
		Repair		0.7					1,14	D
09	SUPPORT ITEMS	Inspect	0.8							
		Service	0.5						6,9,12	
		Remove/ Install	1.5	0.3					4	



## Section III TOOL AND TEST EQUIPMENT REQUIREMENTS

(1) Reference Code	(2) Maintenance Category	(3) Nomenclature	(4) National/NATO Stock Number	(5) Tool Number
1	O	Shop Equipment Automotive Maint & Repair Common #1 Plus Metric Option	4910-00-754-0654	
2	O	Tool Kit, Carpenters Engineer Squad	5180-00-293-2875	
3	O	Tool Kit, General Mechanics Automotive Plus Metric Option	5180-00-177-7033	
4	O,F,H	Tool Kit Light Machine Repair	5180-00-596-1540	
5	C	Brush, Wire	7920-00-291-5815	
6	C	Screwdriver, Cross Tip No. 2	5120-00-234-8913	
7	C	Screwdriver, Flat Tip	5120-00-234-8910	
8	C	Screwdriver Set, Jeweler's	5120-00-288-8739	
9	C	Watchmaker's Blower	5120-00-754-4612	
10	C	Wrench, Adjustable	5120-00-264-3795	
11	C	Grease Gun	4930-00-965-0288	
12	C	Brush, Lens	7920-00-205-0565	
13	O	Spring Scale	6670-00-238-9777	
14	O,F, H	Rivet Gun	5120-00-017-2849	

Section IV REMARKS

Reference Code

Remarks

- A Printed circuit boards will be repaired at the general support maintenance level to the maximum extent possible as required by AR 750-1
- B See TM 5-4120-367-14 for maintenance procedures.
- C See TM 11-5895-1079-41 and TM 11-5895-1079-24P for maintenance procedures
- D Maintenance personnel and TSS section 7, maintenance van (which carries the required tools) are authorized by HHC TOE 05336 H600.

## APPENDIX C

### COMPONENTS OF END ITEM AND BASIC ISSUE ITEMS LISTS

#### Section I INTRODUCTION

##### C-1 . SCOPE.

This appendix lists components of end item and basic issue items for the Collection Section to help you inventory items required for safe and efficient operation.

##### C-2. GENERAL.

The Components of End Item and Basic Issue Items Lists are divided into the following sections:

*a. Section II: Components of End Item.* This listing is for informational purposes only, and is not authority to requisition replacements. As part of the end item, these items must be with the end item whenever it is issued or transferred between property accounts, Illustrations are furnished to assist you in identifying the items.

*b. Section III: Basic Issue Items.* These are the minimum essential items required to place the Collection Section in operation, to operate it, and to perform emergency repairs. BII must be with the Collection Section during operation and whenever it is transferred between property accounts. The illustrations will assist you with hard-to-identify items. This manual is your authority to request/requisition replacement BII based on TOE/MTOE authorization of the end item.

##### C-3. EXPLANATION OF COLUMNS.

The following provides an explanation of columns found in the tabular listings:

*a. Column (1): Illustration Number (Illus Number).* This column indicates the number of the illustration in which the item is shown.

*b. Column (2): National Stock Number.* Indicates the National stock number assigned to the item and will be used for requisitioning purposes.

*c. Column (3): Description.* Indicates the Federal item name and, if required, a minimum description to identify and locate the item. The last line for each item indicates the FSCM (in parentheses) followed by the part number.

*d. Column (4): Unit of Measure (U/M).* Indicates the measure used in performing the actual operational/maintenance function. This measure is expressed by a two-character alphabetical abbreviation (e.g., ea, in, pr).

*e. Column (5): Quantity Required (Qty Rqr).* Indicates the quantity of the item authorized to be used with/on the equipment.

Section II COMPONENTS OF END ITEM

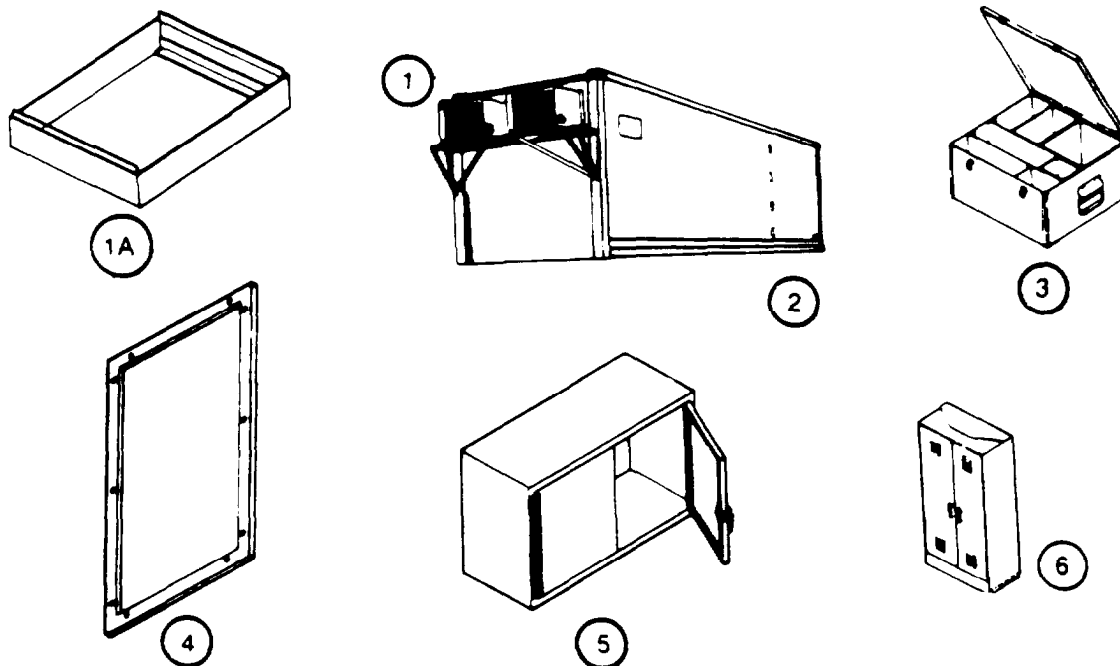

(1) Illus Number	(2) National Stock Number	(3) Description FSCM and Part Number	(4) U/M	(5) Qty Rqr
1	4120-00-974-7206	AIR CONDITIONER (81349) MIL-A-52767	ea	2
1A		BASE, FILING CABINET: (88915) S4634	ea	1
2	6675-01-220-2583	VAN ASSEMBLY; MODIFIED: (97403) 13225E3036	ea	1
3		BOX, VEHICULAR ACCESSORIES for cleaner, vacuum: (97403) 13225E3490	ea	1
4	7195-00-105-7941	BULLETIN BOARD: (79819)T5-2303	ea	1
5		CABINET, WALL STORAGE, TECH MANUALS: (97403) 13225E4648	ea	1
6	7125-00-764-5744	CABINET, SUPPLY: (81348) AA-C-1770, type I, class I, size 2	ea	2

Section II COMPONENTS OF END ITEM - Cont

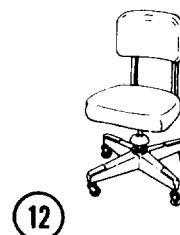
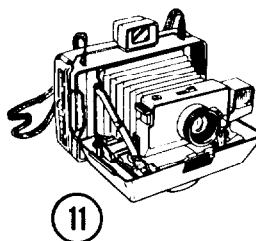
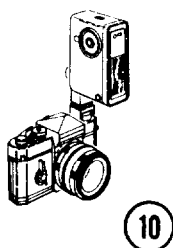
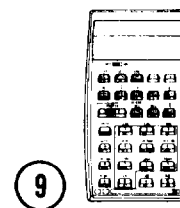
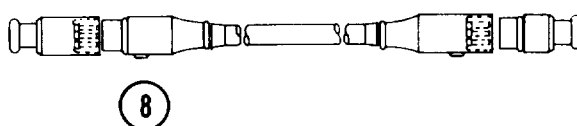
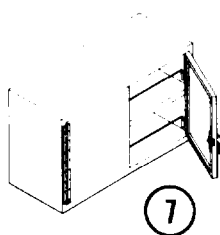

(1) Illus Number	(2) National Stock Number	(3) Description FSCM and Part Number	(4) U/M	(5) Qty Rqr
7	7125-00-286-5259	CABINET, WALL STORAGE: (78252) MIL-C-40060/1, type I	ea	7
8	6150-00-134-0847	CABLE ASSEMBLY, POWER ELECTRICAL: (90129) RC 1736-5, except 50.5 ft lg	ea	2
9	7420-01-139-7441	CALCULATING MACHINE: (51174) HP-32E	ea	1
10	6720-00-602-5099	CAMERA SET, STILL PICTURE: (06400) Camera Set KS-99C	se	2
11	6720-01-064-8071	CAMERA SET, (INSTANT) STILL PICTURE: (47904) Model EE100	ea	2
12	7110-00-273-8791	CHAIR, ROTARY: (81348) AA-C-293, type II, class 2	ea	3

Section II COMPONENTS OF END ITEM - Cont

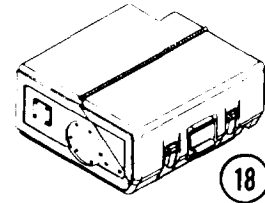
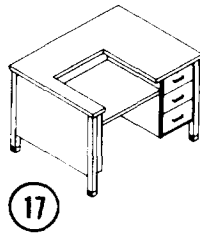
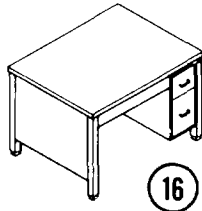
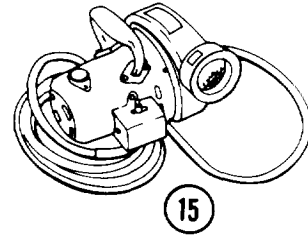
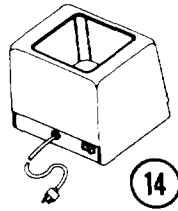
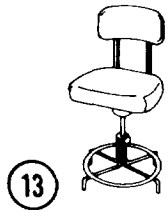

(1)	(2)	(3) Description	(4)	(5)
Illus Number	National Stock Number	FSCM and Part Number	U/M	Qty Rqr
13	7110-00-281-4469	CHAIR, ROTARY: (81348) AA-C-295, class 2, size 2	ea	3
14	4940-01-118-1890	CLEANER, ULTRASONIC: (79819) 3069 USC 3	ea	1
15	7910-00-205-3400	CLEANER, VACUUM, ELECTRIC: (51745) MVV 3400	ea	1
16	7110-01-135-1996	DESK, FLAT TOP: (79819) HN-7303	ea	2
17	7110-00-132-6554	DESK, TYPEWRITER: (37296) AA-D-191, type II, class 2	ea	1
18	5815-01-067-4655	FACSIMILE SET: (12813) 705681-802	ea	1

Section II COMPONENTS OF END ITEM - Cont

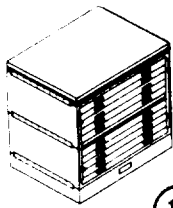

19

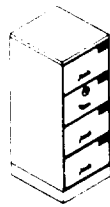

20

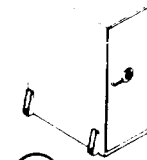

21

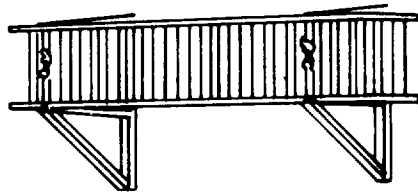

22

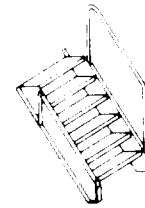

23

(1) Illus Number	(2) National Stock Number	(3) Description FSCM and Part Number	(4) U/M	(5) Qty Rqr
19		FILING ASSEMBLY, MAP AND PLAN: (97403) 13225E3138	ea	2
20	7110-00-920-9320	FILING CABINET, SECURITY: (54427) AA-F-358	ea	2
21	7110-00-068-7736	FILING CABINET, MAP AND PLAN SECURITY: (81348) AAFO0363	ea	2
22	5440-01-152-7751	LADDER, EXTENSION-FOLDING: (39428) 8028T16	ea	1
23	2540-01-133-9726	LADDER, VEHICLE BOARDING: (97403) 13225E3074	ea	2

Section II COMPONENTS OF END ITEM - Cont

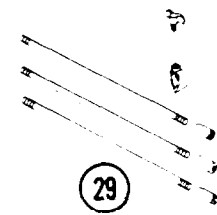
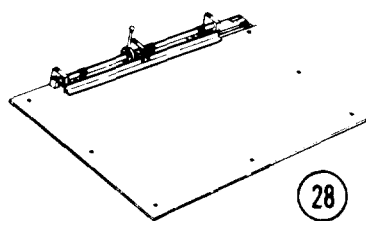
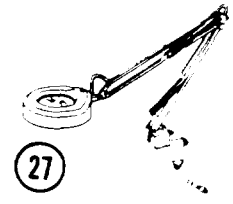
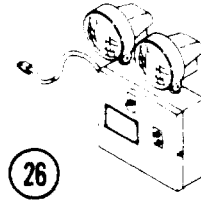
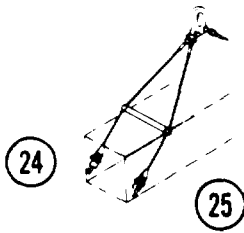

(1) Illus Number	(2) National Stock Number	(3) Description FSCM and Part Number	(4) U/M	(5) Qty Rqr
24		LIFTING AND TIEDOWN DEVICE, TRANSPORTABLE SHELTER: Left hand (52555) 1390-4	ea	2
25		LIFTING AND TIEDOWN DEVICE, TRANSPORTABLE SHELTER: Right hand (52555) 1390-3	ea	2
26		LIGHT, EMERGENCY: (97403) 13225E3396	ea	1
27	6650-00-477-9613	MAGNIFIER: monocular, lamp type (15607) KFM-1/B5d	ea	3
28	6675-01-175-5914	PIN REGISTER BOARD, CARTOGRAPHIC (25042) 0510247	ea	1
29	5975-00-878-3791	ROD, GROUND: (82370) A104	ea	1



Section II COMPONENTS OF END ITEM - Cont

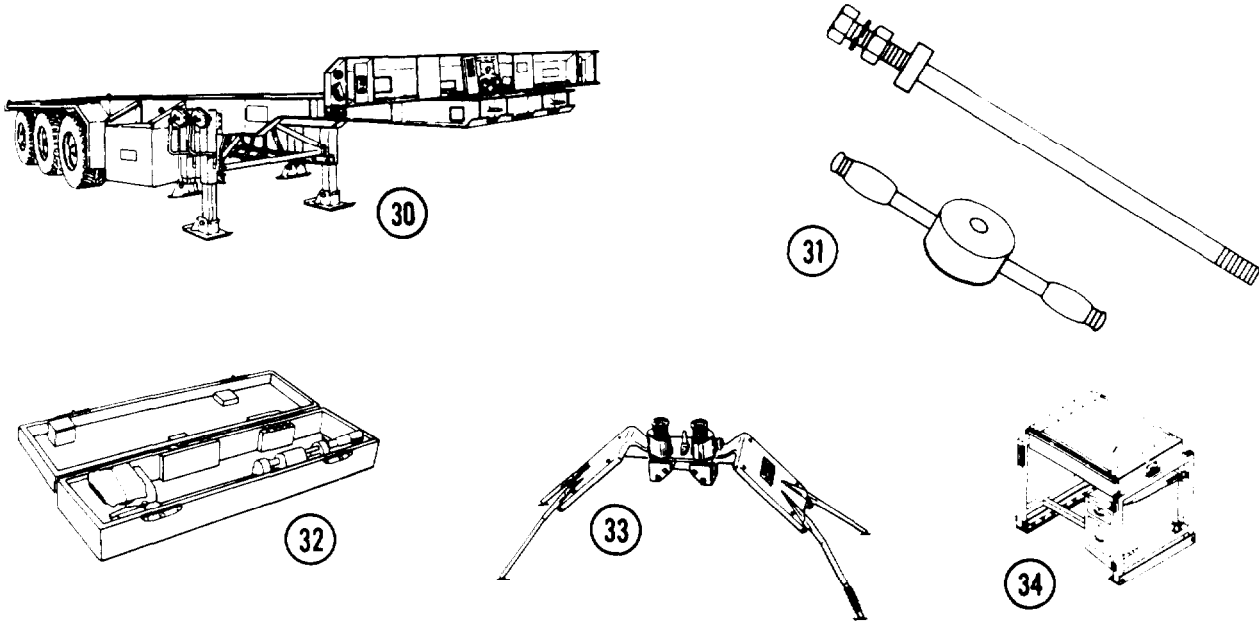

(1) Illus Number	(2) National Stock Number	(3) Description  FSCM and Part Number	(4) U/M	(5) Qty Rqr
30	2330-01-076-4797	SEMITRAILER, FLATBED: (97403) TL/MIL-B-13207, par. 3.11, Fig 12, tables III and IV	ea	1
31	5120-01-013-1676	SLIDE HAMMER, GROUND ROD EMPLACEMENT: (45225) P74-144	ea	1
32	6675-01-173-8161	STEREOMETER PARALLAX BAR: (00048) 122GE	ea	1
33	6675-00-641-3558	STEREOSCOPE, LENS-PRISM-MIRROR, AERIAL PHOTOGRAPHIC INTERPRETATION (81349) MILS 20660	ea	1
34	6675-01-203-1049	TABLE, SCRIBING, TRACING, DRAFTING: (33363) 99-9933	ea	3

Section II COMPONENTS OF END ITEM - Cont

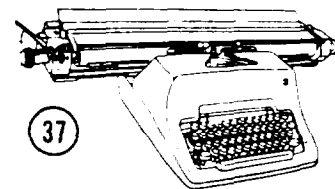
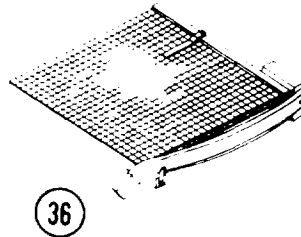
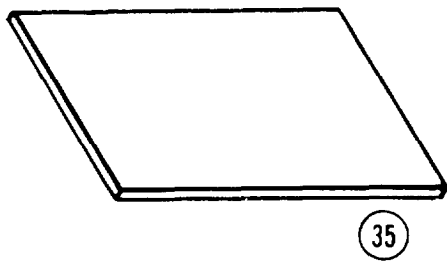

(1) Illus Number	(2) National Stock Number	(3) Description FSCM and Part Number	(4) U/M	(5) Qty Rqr
35		TOP, FILING CABINET: (88915) T3445	ea	1
36	7520-00-224-7621	TRIMMER, PAPER, DROP KNIFE: (81348) GG-T-678-TYPE-1, Class 5	ea	1
37	7430-00-663-9102	TYPEWRITER, MANUAL: (61634) S27	ea	1

Section III BASIC ISSUE ITEMS

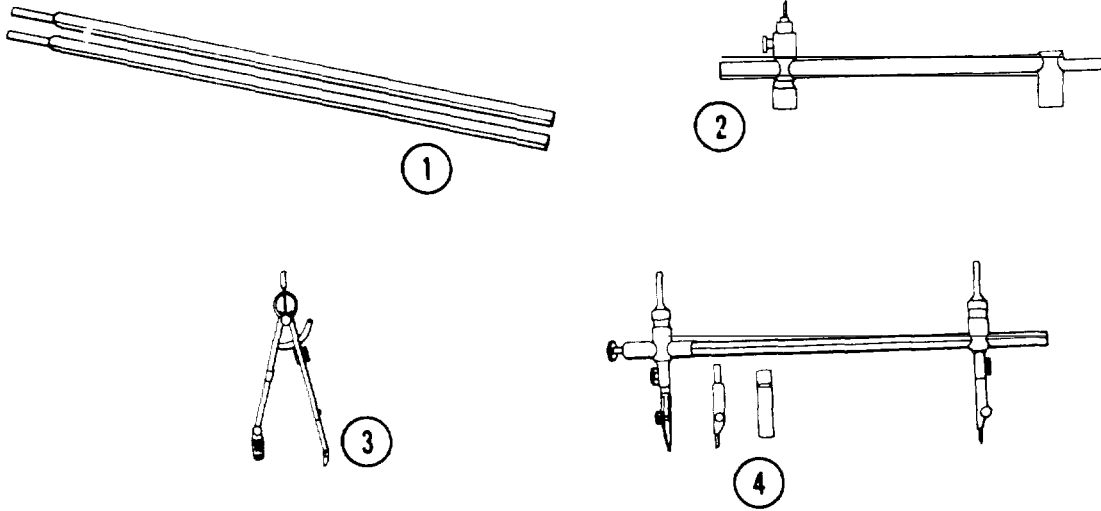

(1) Illus Number	(2) National Stock Number	(3) Description FSCM and Part Number	(4) U/M	(5) Qty Rqr
1	6675-01-114-7226	BAR, EXTENSION, BEAM, COMPASS: (33363) 55-1818	ea	2
2	7920-00-291-5812	BEAM, ATTACHMENT, DRAFTING COMPASS: (79819) 3175B	ea	2
	7920-00-291-5812	BRUSH, DUSTING, DRAFTSMAN'S: (79819) Q6-38NB-010	ea	4
	7920-00-205-0565	BRUSH, LENS (17866) R698	ea	1
	7920-00-291-5815	BRUSH, WIRE, SCRATCH: (39428) 7187T2	ea	1
	8465-00-521-3057	CASE, CARRYING: (85968) No. 5100-450A	ea	1
3	6675-00-459-8935	COMPASS, DRAFTING BEAM: (79819) 3175	ea	2
4	6675-00-904-1947	COMPASS, DRAFTING BEAM: (33363) 55-1806	ea	2

Section III BASIC ISSUE ITEMS - Cont

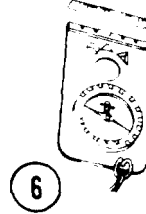
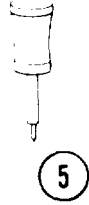

(1) Illus Number	(2) National Stock Number	(3) Description FSCM and Part Number	(4) U/M	(5) Qty Rqr
5	6675-01-071-8912	COMPASS, DRAFTING LEAD ATTACHMENT: (79819) 3175LA	ea	2
6	6605-00-553-8795	COMPASS, MAGNETIC, UNMOUNTED: (04016) 2VOYAGER	ea	1
		COVER, WORKING SURFACE, BOARD DRAFTING: (33363) 99-9970	ea	5
	6675-00-250-2508	CURVE, DRAFTING, IRREGULAR: French type (79819) 8255-A	ea	3
	6675-00-250-2509	CURVE, DRAFTING, IRREGULAR: ship type (17866) 2217-107	ea	3
	6675-00-641-3512	DIVIDERS, DRAFTING, PLAIN: (33363) 55-1794	ea	3
	6675-00-240-2094	DIVIDERS, DRAFTING, PLAIN: (33363) 55-1770	ea	1
	6675-00-240-2049	DIVIDERS, DRAFTING, PROPORTIONAL: (81349) MIL-D-3467, type I	ea	2

Section III BASIC ISSUE ITEMS - Cont

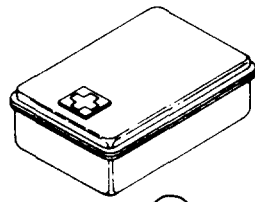

8



9

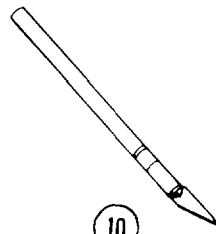

10

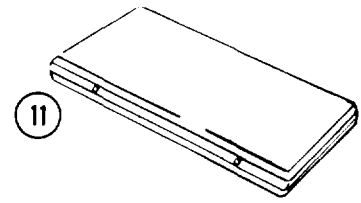

11

(1) Illus Number	(2) National Stock Number	(3) Description FSCM and Part Number	(4) U/M	(5) Qty Rqr
	6675-00-599-8880	DI VIDERS, EQUAL SPACING: 6.0 in. 39428) 1995D11, 6 in	ea	1
	6675-00-599-8879	DIVIDERS, EQUAL SPACING: 12.0 in. 39428) 1995D12, 12 in.	ea	1
7	4210-00-555-8837	EXTINGUISHER, FIRE, MONOBROMO- TRIFLUOROMETHANE: (81349) MIL-E-52031	ea	2
8	6545-00-922-1200	FIRST AID KIT, GENERAL PURPOSE: (89875) SCC-6545-IL	ea	1
9	6660-00-826-1655	GAGE, PRECIPITATION: (7D560) 89048	ea	1
	4930-00-965-0288	GREASE GUN (77335) 550	ea	1
	7510-00-927-8685	KIT, PEN CLEANING: (33363) 61-3115	kt	3
10	5110-00-595-8400	KNIFE, CRAFTSMAN'S (99941) No. 3001	ea	3
	7520-00-295-6170	LEAD REPOINTER, PENCIL: (79819) 234	ea	3
	7520-01-008-7640	LEAD REPOINTER, PENCIL: (79819) 992WB	ea	3
11	6675-00-551-0785	LETTERING SET: (33363) 61-2901	ea	1
	6675-00-190-5854	LINE GUIDE, LETTERING, NONADJUSTABLE: (17866) 2030B6	ea	4

Section III BASIC ISSUE ITEMS - Cont

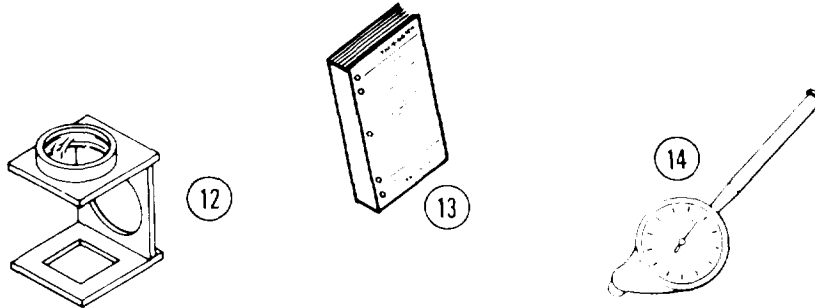

(1) Illus Number	(2) National Stock Number	(3) Description FSCM and Part Number	(4) U/M	(5) QTY Rqr
12	6650-00-255-8268	MAGNIFIER: linen tester (22527) 12-064-10	ea	3
13		MANUALS, TECHNICAL  LO 5-6675-322-14, Lubrication Order, TSS, Collection Section  TM 5-6675-322-14, Operators, Organiza- tional, DS & GS Maintenance Manual, TSS, Collection Section  TM 5-6675-322-24P, Repair Parts and Special Tools List, TSS, Collection Section	ea	1
14	6675-00-222-2542	MEASURER, MAP: (33363) 62-0300	ea	
	6660-00-446-8707	MEASURING STICK, PRECIPITATION GAGE: (04024) 5100-452	ea	

Section III BASIC ISSUE ITEMS - Cont

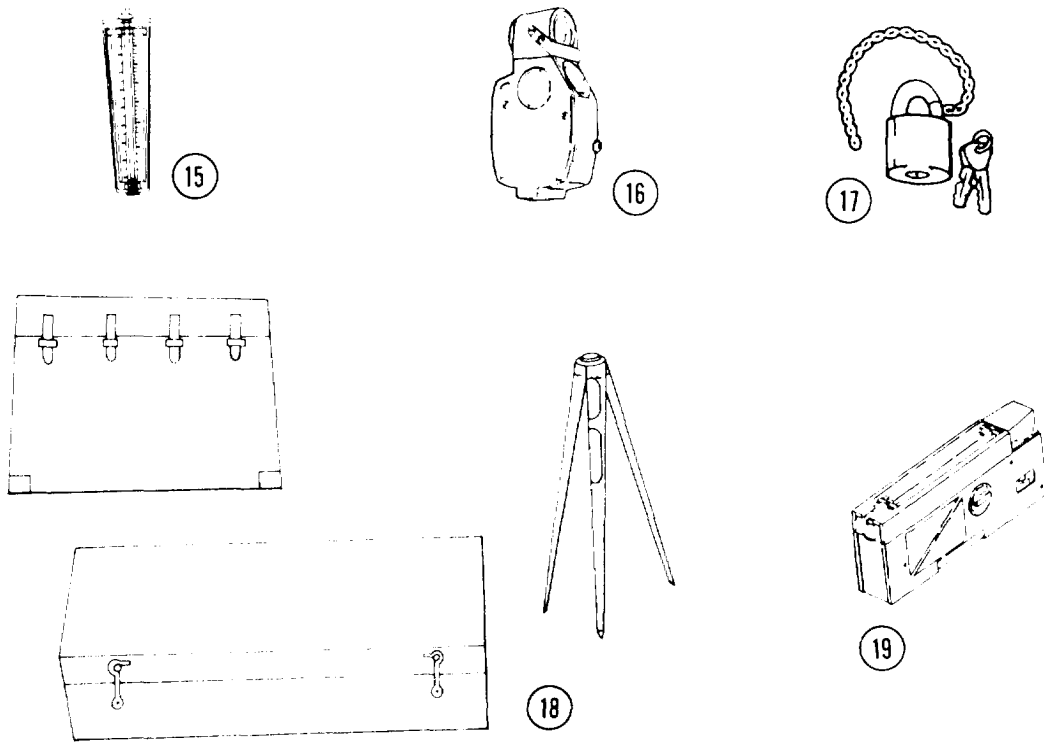

(1) Illus Number	(2) National Stock Number	(3) Description FSCM and Part Number	(4) U/M	(5) Qty Rqr
15	6680-00-833-7010	METER, AIR VELOCITY: (7D560) 89001	ea	1
16	6675-01-168-4229	OPTICAL TREE MEASURER: (04024) 43865	ea	1
17	5340-00-682-1505	PADLOCK SET: (96906) MS 21313-52	se	1
18	6675-00-335-3582	PLANE TABLE, SURVEYING: (81349) MIL-P-10813, type II, class2	ea	1
19	6685-01-136-2137	PSYCHROMETER: (23667) Model 566-3	ea	1

Section III BASIC ISSUE ITEMS - Cont

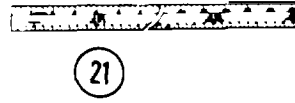
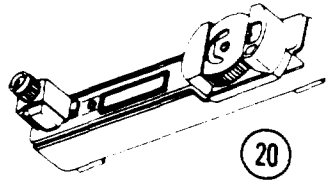

(1) Illus Number	(2) National Stock Number	(3) Description FSCM and Part Number	(4) U/M	(5) Qty Rqr
	6675-00-183-6485	PROTRACTOR, SEMICIRCULAR: (79819) Q6-M276, 6 in.	ea	1
	6675-00-222-2535	PROTRACTOR, SEMICIRCULAR: (73539) M276, 12 in.	ea	3
20		RANGE FINDER, OPTICAL: (73996) 8031-31	ea	1
	6675-00-240-2056	ROD, STADIA: (7D560) 43478, 12 ft lg	ea	3
21	5210-00-273-1965	RULE, STEEL, MECHINIST'S (57163) CME 600	ea	1
	6675-00-641-5727	SCALE, DRAFTING: (33363) 56-3280	ea	3
	6675-00-238-3498	SCALE, DRAFTING: (79819) 3262, 12 in.	ea	1
	6675-00-283-0035	SCALE, PLOTTING: (81348) GG-S-161	ea	3
	6675-00-283-0037	SCALE, PLOTTING: (81348) GG-S-161	ea	3
	6675-00-283-0027	SCALE, PLOTTING: (81348) GG-S-161	ea	3
	6675-00-283-0022	SCALE, PLOTTING: (81 348) GG-S-161	ea	1



Section III BASIC ISSUE ITEMS - Cont

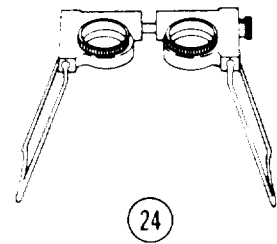
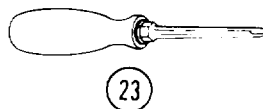
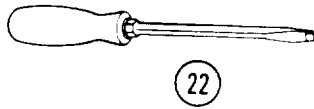

(1) Illus Number	(2) National Stock Number	(3) Description FSCM and Part Number	(4) U/M	(5) Qty Rqr
22	5120-00-234-8913	SCREWDRIVER, CROSS TIP: size 2 (81348) GGG-S-121	ea	1
23	5120-00-234-8910	SCREWDRIVER, FLAT TIP: (78525) 1006	ea	1
	5120-00-288-8739	SCREWDRIVER SET, JEWELER'S (80244) GGG-S-1808 TY1	ea	1
	7510-00-224-7242	SHIELD, ERASING: (7981 9) 03-605	dz	1
24	6675-00-641-3561	STEREOSCOPE, LENS, AERIAL PHOTOGRAPH INTERPRETATION: (7D560) 51034, Abrams Model SV-1	ea	3
		STRAIGHTEDGE: (33363) 56-4150	ea	1
		STRAP ASSEMBLY, BUCKLE END: 6.0 in. (51745) 1844-104	ea	10
		STRAP ASSEMBLY, TIP-END: 8.0 in. (51745) 1845-107	ea	7
		STRAP ASSEMBLY, TIP-END: 36.0 in. (51745) 1845-106	ea	3
		STRAP ASSEMBLY, WEBBING: 30.00 in. (9831 3) 13225 E3695-8	ea	3
		STRAP ASSEMBLY, WEBBING: 35,00 in. (98313) 13225E3695-2	ea	1

Section III BASIC ISSUE ITEMS - Cont

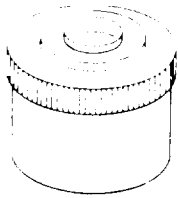

25

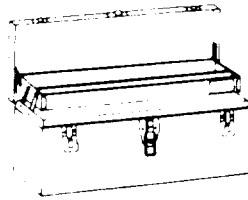

26

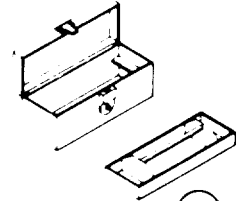

27

(1)	(2)	(3) Description	(4)	(5)
Illus Number	National Stock Number	FSCM and Part Number	UIM	Qty Rqr
		STRAP ASSEMBLY, WEBBING: 38,00 in. (98313) 13225E3695-7	ea	1
		STRAP ASSEMBLY, WEBBING: 55.00 in. (9831 3) 13225 E3695-6	ea	6
		STRAP ASSEMBLY, WEBBING: 29,00 in. (9831 3) 13225E3695-13	ea	2
25		TANK, MINIATURE ROLL FILM: (19139) 152-0873	ea	2
	5210-00-221-1888	TAPE, MEASURING: (26741) C216D, 100 ft	ea	2
	6675-00-253-5501	TEMPLATE, DRAFTING: (79819) 830140	ea	4
26	5140-00-331-5496	TOOL BOX, PORTABLE: 1 fixed hinged tray (75206) CS19	ea	4
27	5140-00-315-2747	TOOL BOX, PORTABLE: 1 removable tray (75206) CS16	ea	1
	6675-00-190-5863	TRIANGLE, DRAFTING: 245 degs (33363) 57-0292, 10 in	ea	3
	6675-00-190-5867	TRIANGLE, DRAFTING: 130 deg, 160 deg (33363) 57-0220, 10 in.	ea	3
	6675-00-190-5857	TRIANGLE, DRAFTING: 245 degs (33363) 57-0292, 6 in	ea	1
	6675-00-183-6487	T-SQUARE (81562) 8068E, 42 in.	ea	2

Section III BASIC ISSUE ITEMS - Cont

(1) Illus Number	(2) National Stock Number	(3) Description FSCM and Part Number	(4) U/M	(5) Qty Rqr
28	5120-00-224-7271	VISE, PIN: (18037) PVDE	ea	6
	5120-00-754-4612	WATCHMAKER'S BLOWER (64959) R8950	ea	1
29	5120-00-264-3795	WRENCH, ADJUSTABLE: (80244) GGG-W-631 TY1 CL1	ea	1



**APPENDIX D**

**ADDITIONAL AUTHORIZATION LIST**

**Section I INTRODUCTION**

**D-1. SCOPE.**

This appendix lists additional items you are authorized for the support of the Collection Section.

**D-2. GENERAL.**

This list identifies items that do not have to accompany the Collection Section and that do not have to be turned in with it. These items are all authorized to you by CTA, MTOE, TDA or JTA.

**D-3. EXPLANATION OF LISTING.**

National stock numbers, descriptions and quantities are provided to help you identify and request the additional items you require to support this equipment. The items are listed in alphabetical sequence by item name under the type document (i. e., CTA, MTOE, TDA, or JTA) which authorizes the item(s) to you.

**Section II ADDITIONAL AUTHORIZATION LIST**

(1) National Stock Number	(2) Description  FSCM and Part Number	(3)  U/M	(4)  Qty Auth
<u>TOE AUTHORIZED ITEMS</u>			
5810-01-048-8167	Case, Battery Z-AIJ/TSEC	ea	1
5810-01-026-9618	Elec. Transfer Keying Device: KYK-13/TSEC	ea	1
6115-00-258-1622	Gen. Set, DSL Eng TM: 60 KW	ea	1
5810-01-026-9619	Net Control Device NCD: KYK-15/TSEC	ea	1
Z54324	Radio Set: AN/GRC- ( ) -VI	ea	2

Section II ADDITIONAL AUTHORIZATION LIST - Cont

(1) National Stock Number	(2) Description  FSCM and Part Number	(3)  U/M	(4)  Qty Auth
<u>TOE AUTHORIZED ITEMS - Cont</u>			
6675-00-641-3632	Sketch Set, Surveying: MIL Field Sketch	ea	1
5810-00-434-3644	Speech Security Equipment: TSEC/KY-57	ea	1
5810-01-026-9620	Tape Reader, General Purpose: KOI-18/TSEC	ea	1
5805-00-543-0012	Telephone Set: TA-312/PT	ea	2
6635-00-641-3643	Test Set, Soil: (ARMY)	ea	1
6635-00-542-1284	Test Set, Soil Trafficability	ea	1
6675-00-641-5735	Transit, Pocket: Clinometer 0 to 90 degrees	ea	3

## Section II EXPENDABLE/DURABLE SUPPLES AND MATERIALS LIST - Cont

(1) Item Number	(2) Level	(3) National Stock Number	(4) Description	(5) U/M
		7510-00-161-4291	Clip, Paper (7981 9) P2-72620	bx
5	C	8305-00-222-2423	Cloth, Cheesecloth	yd
		8220-00-299-8625	Cotton, Nonsterile (81348) JJJ-C-561, grade B	pk
6	C	6515-00-303-8250	Cotton Swabs	bg
7	C	7930-00-530-8067	Detergent, General Purpose	gl
		7520-00-285-1772	Dispenser, Pressure Sensitive Adhesive Tape: (79819) C-22	ea
		7530-00-268-3994	Envelope, Wallet (87263) 1355E	bx
		7510-01-035-1317	ERASER KIT: (79819) 290-K	kt
		7510-01-099-3953	Eraser, Liquid (79819) 292-F	bt
		7510-01-034-1278	Eraser, Film (79819) 9600	bx
		7510-00-634-5034	Eraser, Rubber (79819) T-7099B	dz
		6750-00-260-1252	Film, Photographic (80244) 165-3971	ro
8	F	5610-00-618-0258	Floor Patch	gl
9	o	9150-00-190-0904	Grease, GAA	lb
		7510-01-028-2877	Ink, Drawing (79819) 3072-F1	bt
		7510-01-070-8947	Ink, Drawing (79819) 3084-F1	bt
		7510-01-039-5075	Ink, Drawing: Carmine (79819) 3080-F1	bt

**Section II EXPENDABLE/DURABLE SUPPLIES AND MATERIALS LIST-Cont**

(1) Item Number	(2) Level	(3) National Stock Number	(4) Description	(5) U/M
		7510-0 0-035-8133	Ink, Drawing: Blue (79819) 3080-F1	bt
		7510-0 0-035-8131	Ink, Drawing: Brown (79819) 3080-F1	bt
		7510-0 0-035-8132	Ink, Drawing: Green (79819) 3080-F1	bt
		7510-01-036-3726	Ink, Drawing: Orange (79819) 3080-F1	bt
		7510-01-080-1481	Ink, Drawing: Red (79819) 3808-F1	bt
		7510-01-036-3725	Ink, Drawing: Violet (79819) 3080-F1	bt
		7510-01-035-8130	Ink, Drawing: Yellow (79819) 3080-F1	bt
			Jar, Screw Cap: (05668) 6029-40	ea
		7510-00-281-2143	Lead, Pencil, Graphite: HB (79819) 2200-HB	bx
		7510-00-285-5865	Lead, Pencil, Graphite: F (79819) 2200-F	pk
		7510-00-285-5866	Lead, Pencil, Graphite: H (79819) 2200-H	pk
		7510-00-285-5863	Lead, Pencil, Graphite: 2H (79819) 2200-2H	pk
		7510-00-272-9820	Lead, Pencil, Graphite: 3H (79819) 2200-3H	pk
		7510-00-285-5864	Lead, Pencil, Graphite: 4H (79819) 2200-4H	pk
		7510-00-285-5862	Lead, Pencil, Graphite: HB (81239) F-370HB	pk
		7510-00-285-5847	Lead, Pencil, Graphite: 2H (81239) F350-2H	pk



## Section II EXPENDABLE/DURABLE SUPPLIES AND MATERIALS LIST - Cont

(1) Item Number	(2) Level	(3) National Stock Number	(4) Description	(5) U/M
10	F	9150-00-273-2389	Oil, Lubricating, General Purpose	cn
		7530-00-285-3083	Pad, Writing Paper (8D190) M9-21-112	pk
11	O	8010-01-131-6254	Paint, Black	kt
11A	O	8010-01-160-6745	Paint, Brown	kt
11B	O	8010-01-162-5578	Paint, Green	kt
12	O	8010-00-298-3859	Paint, Light Green, INT.	gl
13	C	5350-00-619-9166	Paper, Abrasive	pk
		7530-00-871-8310	Paper, Drawing (33363) 15-2155	pk
		7530-00-985-7269	Paper, Drawing (33363) 15-7155	pk
		7530-00-985-7260	Paper, Drawing (33363) 15-2155	pk
			Paper, Graph (33363) 48-5094	ro
			Paper, Graph (33363) 48-6020	ro
		6640-00-597-6745	Paper, Lens: tissue (22527) 11-996	pk
		7520-01-006-4496	Paper, Tracing (33363) 10-9155	pk
		7510-00-286-6985	Paperweight: Leather Covered (33353) 58-0810	ea
		7510-01-030-7427	Pen Point Assortment and Penholder (79819) 3095-JDCS 9	se
		6675-01-107-9678	Pen Points (79819) 92-J, 0,13 mm	ea
		6675-01-098-1219	Pen Points (79819) 92-J, 0.18 mm	ea

Section II EXPENDABLE/DURABLE SUPPLIES AND MATERIALS LIST - Cont

(1) Item Number	(2) Level	(3) National Stock Number	(4) Description	(5) U/M
		6675-01-098-1220	Pen Points (79819) 92-J, 0.25 mm	ea
		6675-01-107-9679	Pen Points (79819) 92-J, 0.35 mm	ea
		6675-01-098-1221	Pen Points (79819) 92-J, 0.50 mm	ea
		6675-01-099-3440	Pen Points (79819) 92-J, 0.70 mm	ea
		6675-01-098-0308	Pen Points (79819) 92-J, 1.00 mm	ea
		6675-01-098-1222	Pen Points (79819) 92-J, 1.40 mm	ea
		6675-01-097-4516	Pen Points (79819) 92-J, 2.00 mm	ea
		7510-00-233-2027	Pencil: colored; thin lead; blue (79819) 1344, blue	dz
		7510-00-264-4610	Pencil: colored; thin lead: green (79819) 1800-16, green	dz
		7510-00-233-2021	Pencil: colored; thin lead; red (7981 9) 1800-39, red	dz
		7510-00-264-4608	Pencil: glazed, extra thick lead; yellow (79819) 1800-5, yellow	dz
		7510-00-240-1526	Pencil: glazed, extra thick lead; black (7981 9) 1555, black	dz
		7510-00-436-5210	Pencil: glazed, extra thick lead; blue (79819) 1555, blue	dz
		7510-00-275-7212	Pencil: glazed, extra thick lead; green (79819) 1555, green	dz
		7510-00-174-3205	Pencil: glazed, extra thick lead: red (79819) 1555, red	dz
		7520-00-161-5664	Pencil, Mechanical: automatic (81 239) P400	ea

## Section II EXPENDABLE/DURABLE SUPPLIES AND MATERIALS LIST - Cont

(1) Item Number	(2) Level	(3) National Stock Number	(4) Description	(5) U/M
14	C	7520-01-083-6734	Pencil, Mechanical: non automatic (79819) 5611	ea
		6750-00-868-7901	Picture Pack, Rapid Processing Photographic (29556) 108 POLACOLOR 2	pk
		7510-00-174-7343	Pin, Straight	bx
		9920-00-292-9946	Pipe Cleaners	pk
		9930-00-282-8323	Plastic Sheet	pk
		9330-00-285-7698	Plastic Sheet	pk
				Plastic Sheet (33363) 44-1057
15	O F	8010-01-193-0520	Primer	k t
		8010-01-030-7254	Resin, Epoxy	kt
		7510-00-543-6792	Refill, Ball Point Pen (79819) VER-4	dz
		7510-00-926-9146	Ribbon, Typewriter (79819) 02-K25B	ea
		7510-00-243-3435	Rubber Band (7981 9) N 18366-64	bx
16	O		Screen, Nylon (39428) 1017A31	ro
17	O	8040-00-851-0211	Sealant, Silicone	tu
		5110-00-161-6912	Shears, Straight Trimmers: (8D190) Q9-3769	ea
18	O	3439-00-273-3722	Solder, Rosin Core	sl
19	O	6850-00-274-5421	Solvent, P-D-680	cn
20	O	6850-00-880-1013	Spray, Silicone	cn

**Section II EXPENDABLE/DURABLE SUPPLIES AND MATERIALS LIST - Cont**

(1) Item Number	(2) Level	(3) National Stock Number	(4) Description	(5) U/M
21	O		Sprayfoam Sealant (39428) 7627T1	cn
		7520-00-281-5895	Stapler, Paper Fastening, Office: (8D1 90) X8-27, gray	ea
		7510-00-272-9662	Staples, Paper Fastening, office type (8D10) 8-SF4-5M	bx
		5345-00-184-1374	Stone, Sharpening: (58692) 42862	ea
22	O	5640-00-103-2254	Tape, Cloth, Duct Sealling, 2 in	ro
		7510-00-634-1549	Tape, Pressure Sensitive Adhesive (76381) 666, 1.0 in.	ro
		7510-00-550-7126	Tape, Pressure Sensitive Adhesive (99742) P45	ro
		7510-00-234-7960	Tape, Pressure Sensitive Adhesive (76381) 600	ro
		7510-00-551-9824	Tape, Pressure Sensitive Adhesive (76381)810	ro
		7510-00-198-5831	Tape, Pressure Sensitive Adhesive (76381) 230	ro
		7510-00-272-6887	Thumbtack (79819) V6-53	hd
23	C	6640-00-597-6745	Tissue, Lens Cleaning	bk
		7920-00-823-9772	Towel, Paper (95135) DW61-1000-22	bx
		4020-00-242-4074	Twine, Fibrous (79819) S9-9	lb

GLOSSARY

ABBREVIATION/TERM	DEFINITION
Absolute Altitude . . . . .	Altitude of aircraft above surface of earth.
Collimating Marks . . . . .	Marks on edge of photograph to indicate optical center of photograph.
Differential Parallax . . . . .	Small linear displacement between same photographic images on different photographs resulting from height of surface.
Diopter. . . . .	Measurement of lens power and refraction.
Fiducial Mark . . . . .	Marks on edges of aerial photographs used to determine center of photograph.
Hectare. . . . .	A metric measure of surface, equal to 10,000 square meters (100 ares, or 2.471 acres).
Interpupillary Distance . . . . .	Distance between center of observer's eyes.
Principal Point of Photograph . . . . .	Center of photographic image.
Stereo-Pair Photograph . . . . .	Photographs taken of same object or area from different positions.
Stereoscopic . . . . .	An apparent three-dimensional image obtained when viewing stereo-pair photographs.



INDEX

SUBJECT PARAGRAPH

COLLECTION SECTION

A

Air Conditioner/Heater, Replace . . . . . 1-20.8  
 Air Conditioner Support Bracket, Replace . . . . . 1-20.9  
 Air Vent Cover, Replace . . . . . 1-16.17  
 Air Vent Screen, Replace . . . . . 1-16.16

B

Ballast, Fluorescent Lamp, Replace . . . . . 1-16.1  
 Blackout/Dome Light, Replace . . . . . 1-10.3  
 Blackout/Dome Light Microswitch, Replace . . . . . 1-16.5  
 Blackout Curtain, Repair.. . . . . 1-16.2  
 Breaker, Circuit, Replace . . . . . 1-20.5

C

Cargo Door Latch Assembly, Replace . . . . . 1-20.2  
 Characteristics, Capabilities, and Features . . . . . 1-2.1  
 Circuit Breaker, Replace.. . . . . 1-20.5  
 Common Tools and Equipment . . . . . 1-12, 1-18  
 Components, Location and Description of Major . . . . . 1-2.2  
 Conditions, Operations Under Unusual . . . . . 1-7  
 Conditions, Operations Under Usual . . . . . 1-6  
 Cover, Air Vent, Replace . . . . . 1-16.17  
 Cover, Exhaust Fan, Replace . . . . . 1-16.10  
 Curtain, Blackout, Repair . . . . . 1-16.12

D

Data, Equipment . . . . . 1-2.3  
 Description and Use of Operator's Controls  
 and Indicators. . . . . 1-4  
 Destruction of Material to Prevent Enemy Use . . . . . 1-1.5  
 Door, Personnel/Cargo, Replace . . . . . 1-20.4  
 Door Handle, Personnel, Repair . . . . . 1-20.1  
 Door Latch Assembly, Cargo, Replace . . . . . 1-20.2  
 Duct, Ventilation, Replace . . . . . 1-20.10  
 Ducts, Ventilation, Service . . . . . 1-10.2

E

Emergency Light Assembly, Replace . . . . . 1-16.11  
 Equipment Data. . . . . 1-2.3  
 Equipment Description . . . . . 1-2  
 Equipment Characteristics, Capabilities, and Features . . . . . 1-2.1  
 Exhaust Fan, Replace. . . . . 1-16.9  
 Exhaust Fan Cover, Replace . . . . . 1-16.10

INDEX - Cont

SUBJECT PARAGRAPH

COLLECTION SECTION - Cont

F

Fan, Exhaust, Replace . . . . . 1-16.9  
 Features, Equipment Characteristics, Capabilities, and . . . . . 1-2.1  
 Filter, Radio Frequency (RF), Replace . . . . . 1-16.2  
 Floor Covering, Repair . . . . . 1-20.6  
 Fluorescent Lamp, Replace. . . . . 1-10.1  
 Fluorescent Lamp Ballast, Replace . . . . . 1-16.1  
 Fluorescent Lamp Switch, Replace . . . . . 1-16.3  
 Forms and Records, Maintenance . . . . . 1-1.3

G

General Information . . . . . 1-1

I

Indicator, Level, Repair . . . . . 1-16.15  
 Indicators, Description and Use of Operator's  
 Controls and. . . . . 1-4  
 Instructions, Lubrication . . . . . 1-8, 1-11

L

Ladder, Personnel, Repair . . . . . 1-16.18  
 Level Indicator, Repair . . . . . 1-16.15  
 Light, Blackout/Dome, Replace . . . . . 1-10.3  
 Light, Emergency Assembly, Replace . . . . . 1-16.11  
 Location and Description of Major Components . . . . . 1-2.2  
 Lubrication Instructions . . . . . 1-8, 1-11

H

Maintenance Procedures . . . . . 1-10, 1-16, 1-20  
 Maintenance Forms and Records . . . . . 1-1.3  
 Microswitch, Blackout/Dome Light, Replace . . . . . 1-16.5  
 Molding, Wire, Replace . . . . . 1-16.7

O

On/Off Switch, Replace . . . . . 1-16.4  
 Operation, Technical Principles of . . . . . 1-3  
 Operation Under Unusual Conditions . . . . . 1-7  
 Operation Under Usual Conditions . . . . . 1-6  
 Operator's Controls and Indicators, Description  
 and Use of. . . . . 1-4  
 Operator Preventive Maintenance Checks and Services . . . . . 1-5  
 Organizational Preventive Maintenance Checks and Services . . . . . 1-14  
 Organizational Troubleshooting . . . . . 1-15



INDEX - Cont

SUBJECT PARAGRAPH

COLLECTION SECTION - Cont

P

Parts, Repair . . . . . 1-12, 1-18  
 Personnel Door Handle, Repair . . . . . 1-20.1  
 Personnel/Cargo Door, Replace . . . . . 1-20.4  
 Personnel/Cargo Door Gasket, Replace . . . . . 1-20.3  
 Personnel Ladder, Repair . . . . . 1-16.18  
 Preparation for Movement.. . . . . 1-6.2  
 Preparation for Storage or Shipment . . . . . 1-17  
 Preventive Maintenance Checks and Services . . . . . 1-5, 1-14  
 Procedures, Maintenance . . . . . 1-10, 1-16, 1-20

R

Radio Frequency (RF) Filter, Replace . . . . . 1-16.2  
 Receipt, Service Upon . . . . . 1-13  
 Receptacle, Replace . . . . . 1-16.6  
 Repair Parts. . . . . 1-12, 1-18  
 Repair:  
     Blackout Curtain . . . . . 1-16.12  
     Floor Covering. . . . . 1-20.6  
     Level Indicator . . . . . 1-16.15  
     Personnel Door Handle . . . . . 1-20.1  
     Personnel Ladder. . . . . 1-16.18  
     Telephone Binding Post Assembly . . . . . 1-16.8  
     Van Body Skin . . . . . 1-16.12, 1-20.7  
 Replace:  
     Air Conditioner/Heater . . . . . 1-20.8  
     Air Conditioner Support Bracket . . . . . 1-20.9  
     Air Vent Cover. . . . . 1-16.17  
     Air Vent Screen . . . . . 1-16.16  
     Blackout/Dome Light . . . . . 1-10.3  
     Blackout/Dome Light Microswitch . . . . . 1-16.5  
     Cargo Door Latch Assembly . . . . . 1-20.2  
     Circuit Breaker . . . . . 1-20.5  
     Emergency Light Assembly . . . . . 1-16.11  
     Exhaust Fan . . . . . 1-16.9  
     Exhaust Fan Cover . . . . . 1-16.10  
     Fluorescent Lamp. . . . . 1-10.1  
     Fluorescent Lamp Ballast . . . . . 1-16.1  
     Fluorescent Lamp Switch . . . . . 1-16.3  
     On/Off Switch . . . . . 1-16.4  
     Personnel/Cargo Door . . . . . 1-20.4  
     Personnel/Cargo Door Gasket . . . . . 1-20.3  
     Radio Frequency (RF) Filter . . . . . 1-16.2  
     Receptacle. . . . . 1-16.6  
     Tiedown Socket. . . . . 1-16.14  
     Ventilation Duct . . . . . 1-20.10  
     Wire Molding. . . . . 1-16.7

INDEX - Cont

SUBJECT PARAGRAPH

COLLECTION SECTION - Cont

S

Scope . . . . . 1-1.1  
 Service Upon Receipt. . . . . 1-13  
 Service Ventilation. Ducts 1-10.2  
 Services, Preventive Maintenance Checks and . . . . . 1-5, 1-14  
 Shipment, Preparation for Storage or . . . . . 1-17  
 Socket, Tiedown, Replace . . . . . 1-16.14  
 Special Tools; Test, Measurement, Diagnostic  
 and Support Equipment. . . . . 1-12, 1-18  
 Switch, Fluorescent Lamp, Replace . . . . . 1-16.3  
 Switch, On/Off, Replace . . . . . 1-16.4

T

Technical Principles of Operation . . . . . 1-3  
 Telephone Binding Post Assembly, Repair . . . . . 1-16.8  
 Tiedown Socket, Replace . . . . . 1-16.14  
 Tools and Equipment, Special . . . . . 1-12, 1-18  
 Tools; Test, Measurement, Diagnostic and  
 Support Equipment, Special . . . . . 1-12, 1-18  
 Troubleshooting . . . . . 1-9, 1-15, 1-19

V

Van Body Skin, Repair . . . . . 1-16.13, 1-20.7  
 Ventilation Duct, Replace . . . . . 1-20.10  
 Ventilation Ducts, Service . . . . . 1-10.2

W

Wire Molding, Replace . . . . . 1-16.7

DRAFTING, SCRIBING/TRACING TABLE

B

Block Assembly, Pillow, Replace. . . . . 2-16.8

C

Characteristics, Capabilities, and Features . . . . . 2-2.1  
 Components, Location and Description of Major. . . . . 2-2.2  
 Conditions, Operation Under Unusual. . . . . 2-7  
 Conditions, Operation Under Usual . . . . . 2-6

INDEX - Cont

SUBJECT	PARAGRAPH
<b>DRAFTING, SCRIBING/TRACING TABLE - Cont</b>	
<b>D</b>	
Data, Equipment . . . . .	2-2.3
Description and Use of Operator's Controls and Indicators. . . . .	2-4
<b>E</b>	
Equipment Description . . . . .	2-2
Equipment, Repair Parts; Special Tools; Test, Measurement, and Diagnostic Equipment; and Support . . . . .	2-12
<b>F</b>	
Fuse, Replace . . . . .	2-10.1
<b>G</b>	
General Information . . . . .	2-1
<b>I</b>	
Indicators, Description and Use of Operator's Controls and. . . . .	2-4
Information. General . . . . .	2-1
Instructions, Lubrication . . . . .	2-8, 2-11
<b>L</b>	
Lamp Ballast, Replace . . . . .	2-16.4
Location and Description of Major Components . . . . .	2-2.2
Lubrication Instructions . . . . .	2-8, 2-11
<b>M</b>	
Maintenance Procedures . . . . .	2-10, 2-16
<b>O</b>	
Operation, Technical Principles of . . . . .	2-3
Operation Under Unusual Conditions . . . . .	2-7
Operation Under Usual Conditions . . . . .	2-6
Operator's Controls and Indicators, Description and Use of. . . . .	2-4
Operator Preventive Maintenance Checks and Services . . . . .	2-5
Organizational Preventive Maintenance Checks and Services. . . . .	2-14
Organizational Troubleshooting . . . . .	2-15

INDEX - Cont

SUBJECT PARAGRAPH

DRAFTING, SCRIBING/TRACING TABLE - Cont

P

Pillow Block, Replace . . . . .	2-16.8
Power Cord, Replace . . . . .	2-16.2
Power Switch, Replace . . . . .	2-16.1
Preparation for Storage or Shipment . . . . .	2-17
Preventive Maintenance Checks and Services . . . . .	2-5, 2-14
Procedures, Maintenance . . . . .	2-10, 2-16

R

Receipt, Service Upon . . . . .	2-13
Repair:	
Assembly, Tilt Locking . . . . .	2-16.6
Repair Parts; Special Tools; Test, Measurement, and Diagnostic Equipment and Support Equipment . . . . .	2-12
Replace:	
Ballast, Lamp . . . . .	2-16.4
Block Assembly, Pillow . . . . .	2-16.8
Cord, Power . . . . .	2-16.2
Fuse. . . . .	2-10.1
Lamp. . . . .	2-16.5
Receptacle . . . . .	2-16.3
Starter . . . . .	2-16.5
Switch, Power . . . . .	2-16.1

S

Scope . . . . .	2-1.1
Services, Preventive Maintenance Checks and . . . . .	2-5, 2-14
Service Upon Receipt . . . . .	2-13
Shipment, Preparation for Storage or . . . . .	2-17

T

Technical Principles of Operation . . . . .	2-3
Tilt Locking Assembly, Repair . . . . .	2-16.6
Troubleshooting . . . . .	2-9, 2-15

INDEX - Cont

SUBJECT PARAGRAPH

**FACSIMILE TRANSMISSION AND RECEIVING DEVICE**

**G**

General Information . . . . . 7-1

**I**

Information, General . . . . . 7-1  
 Information, Reference . . . . . 7-1.2

**R**

Reference Information . . . . . 7-1.2

**S**

Scope . . . . . 7-1.1

**FURNITURE AND CABINETS**

**C**

Cabinet, Map and Plan Filing . . . . . 8-2  
 Cabinet, Map and Plan Filing, Remove/Install . . . . . 8-16.3  
 Cabinet, Map and Plan Security . . . . . 8-2  
 Cabinet, Map and Plan Security, Remove/Install . . . . . 8-16.6  
 Cabinet, Security Filing... . . . . 8-16.8  
 Cabinet, Security Filing, Remove/Install . . . . . 8-16.8  
 Cabinet, Supply . . . . . 8-16.5  
 Cabinet, Supply, Remove/Install . . . . . 8-2  
 Cabinet, Wall Storage . . . . . 8-2  
 Cabinet, Wall Storage, Remove/Install . . . . . 8-16.4  
 Cabinets and Furniture, Inspect . . . . . 8-10.1  
 Chair, Rotary Desk. . . . . 8-2  
 Chair, Rotary Drafting . . . . . 8-2

**D**

Description and Use of Operator's Controls and Indicators . . . . . 8-4  
 Description, Equipment . . . . . 8-2  
 Desk, Flat Top. . . . . 8-2  
 Desk, Flat Top, Remove/Install . . . . . 8-16.9  
 Desk, Typewriter. . . . . 8-2  
 Desk, Typewriter, Remove/Install . . . . . 8-16.7

**E**

Equipment Description . . . . . 8-2

INDEX - Cont

SUBJECT PARAGRAPH

FURNITURE AND CABINETS - Cont

F

Flat Top Desk . . . . . 8-2  
Flat Top Desk, Remove/Install . . . . . 8-16.9

G

General Information . . . . . 8-1

H

Hinge (Piano), Replace . . . . . 8-16.2

I

Information, General . . . . . 8-1  
Inspect Cabinets and Furniture . . . . . 8-10.1  
Instructions, Lubrication . . . . . 8-8, 8-11

L

Latch (Wall Storage Cabinet), Replace. . . . . 8-16.1  
Lubrication Instructions . . . . . 8-8, 8-11

M

Maintenance Procedures . . . . . 8-10, 8-16  
Map and Plan Filing Cabinet . . . . . 8-2  
Map and Plan Filing Cabinet, Remove/Install. . . . . 8-16.3  
Map and Plan Security Cabinet . . . . . 8-2  
Map and Plan Security Cabinet, Remove/Install . . . . . 8-16.6

O

Operation, Technical Principles of . . . . . 8-3  
Operation Under Unusual Conditions . . . . . 8-7  
Operation Under Usual Conditions . . . . . 8-6  
Operator's Controls and Indicators, Description and Use of . . . . . 8-4

P

Preparation for Movement.. . . . . 8-6.1  
Preparation for Storage or Shipment . . . . . 8-17  
Preventive Maintenance Checks and Services . . . . . 8-5, 8-14  
Procedures, Maintenance . . . . . 8-10, 8-16

INDEX - Cont

SUBJECT PARAGRAPH

FURNITURE AND CABINETS - Cont

R

Remove/Install:	
Corkboard . . . . .	8-16.10
Flat Top Desk . . . . .	8-16.9
Map and Plan Filing Cabinet/Portable Drawing Board Assembly . . . . .	8-16.3
Map and Plan Security Cabinet . . . . .	8-16.6
Security Filing Cabinet . . . . .	8-16.8
Supply Cabinet. . . . .	8-16.5
Typewriter Desk . . . . .	8-16.7
Wall Storage Cabinet . . . . .	8-16.4
Replace:	
Door Hinge (Piano Hinge). . . . .	8-16.2
Door Latch (Wall Storage Cabinet). . . . .	8-16.1
Rotary Desk Chair . . . . .	8-2
Rotary Drafting Chair . . . . .	8-2

S

Service Upon Receipt. . . . .	8-13
Scope . . . . .	8-1.1
Security Filing Cabinet	
Security Filing Cabinet, Remove/Install . . . . .	8-16.8
Shipment, Preparation for Storage or . . . . .	8-17
Supply Cabinet. . . . .	8-2
Supply Cabinet, Remove/Install . . . . .	8-16.5

T

Technical Principles of Operation . . . . .	8-3
Troubleshooting Procedures . . . . .	8-9, 8-15
Typewriter Desk . . . . .	8-2
Typewriter Desk, Remove/Install . . . . .	8-16.7

W

Wall Storage Cabinet. . . . .	8-2
Wall Storage Cabinet, Remove/Install . . . . .	8-16.4

INDEX - Cont

SUBJECT PARAGRAPH

LENS-PRISM-MIRROR STEREOSCOPE

A

Adjust Mirror . . . . . 5-10.1

C

Conditions, Operation Under Unusual . . . . . 5-7  
 Conditions, Operation Under Usual . . . . . 5-6

D

Data, Equipment . . . . . 5-2.2  
 Description, Equipment . . . . . 5-2  
 Description and Use of Operator's Controls  
 and Indicators. . . . . 5-4

E

Equipment Characteristics, Capabilities, and Features . . . . . 5-2.1  
 Equipment Data . . . . . 5-2.2  
 Equipment Description . . . . . 5-2

G

General Information . . . . . 5-1  
 Glossary . . . . . 5-1.2

I

Indicators, Description and Use of Operator's  
 Controls and . . . . . 5-4  
 Information, General . . . . . 5-1  
 Instructions, Lubrication . . . . . 5-8, 5-11  
 Instructions, Maintenance . . . . . 5-10, 5-16

L

Lubrication Instructions . . . . . 5-8, 5-11

M

Maintenance Procedures . . . . . 5-10, 5-16  
 Mirror, Adjust . . . . . 5-10.1



INDEX - Cont

SUBJECT PARAGRAPH

LENS-PRISM-MIRROR STEREOSCOPE - Cont

0

Operating Procedures . . . . . 5-6.1  
 Operator's Controls and Indicators, Description  
 and Use of. . . . . 5-4  
 Operation Under Unusual Conditions . . . . . 5-7  
 Operation Under Usual Conditions . . . . . 5-6

P

Preparation for Storage or Shipment . . . . . 5-17  
 Preventive Maintenance Checks and Services . . . . . 5-5, 5-14

S

Scope . . . . . 5-1.1  
 Service Upon Receipt. . . . . 5-13  
 Services, Preventive Maintenance Checks and . . . . . 5-5, 5-14  
 Shipment, Preparation for Storage or . . . . .

T

Technical Principles of Operation . . . . . 5-3  
 Troubleshooting Procedures . . . . . 5-9, 5-15

PARALLAX BAR

A

Assembly and Preparation for Use . . . . . 4-6.1

C

Checks and Services, Preventive Maintenance . . . . . 4-5, 4-14  
 Computations. . . . . 4-6.2  
 Conditions, Operation Under Unusual . . . . . 4-7  
 Conditions, Operation Under Usual . . . . . 4-6  
 Controls and Indicators, Description; and  
 Use of Operator's . . . . . 4-4

D

Data, Equipment . . . . . 4-2.2  
 Description, Equipment . . . . . 4-2  
 Description and Use of Operator's Controls  
 and Indicators. . . . . 4-4

INDEX - Cont

SUBJECT PARAGRAPH

PARALLEX BAR - Cont

E

Equipment Characteristics, Capabilities, Features . . . . .	4-2.1
Equipment Data . . . . .	4-2.2
Equipment Description . . . . .	4-2

G

General Information . . . . .	4-1
Glossary . . . . .	4-1.2

I

Information, General . . . . .	4-8, 4-11
Instructions, Lubrication. . . . .	4-8, 4-11

L

Lubrication Instructions . . . . .	4-8, 4-11
------------------------------------	-----------

M

Maintenance Procedures . . . . .	4-10, 4-16
Micrometer, Read . . . . .	4-6.2
Movement, Preparation for . . . . .	4-6.3

O

Operating Procedures . . . . .	4-6.2
Operator's Controls and Indicators. Description and Use of . . . . .	4-4
Operation Under Unusual Conditions . . . . .	4-7
Operation Under Usual Conditions . . . . .	4-6

P

Procedures, Operating . . . . .	4-6.2
Preparation for Movement . . . . .	4-6.3
Preparation for Storage or Shipment . . . . .	4-17
Preparation for Use, Assembly and . . . . .	4-6.1
Preventive Maintenance Checks and Services . . . . .	4-5, 4-14

R

Read Micrometer . . . . .	4-6.2
---------------------------	-------

INDEX - Cont

SUBJECT PARAGRAPH

**PARALLEX BAR - Cont**

**S**

Scope . . . . .	4-1.1
Service Upon Receipt . . . . .	4-13
Storage or Shipment, Preparation for . . . . .	4-17

**T**

Technical Principles of Operation . . . . .	4-3
Troubleshooting Procedures . . . . .	4-9, 4-15

**POCKET CALCULATOR**

**C**

Characteristics, Capabilities, and Features . . . . .	3-2.1
Conditions, Operation Under Unusual . . . . .	3-7
Conditions, Operation Under Usual . . . . .	3-6

**D**

Data, Equipment Description and . . . . .	3-2.2
Description, Equipment . . . . .	3-2
Description and Use of Operator's Controls and Indicators. . . . .	3-4

**E**

Equipment Data. . . . .	3-2.2
Equipment Description.. . . .	3-2

**G**

General Information . . . . .	3-1
-------------------------------	-----

**I**

Indicators, Description and Use of Operator's Controls and. . . . .	3-4
Information. General . . . . .	3-1
Instructions, Lubrication . . . . .	3-8, 3-11

**L**

Lubrication Instructions . . . . .	3-8, 3-11
------------------------------------	-----------

**INDEX - Cont**

SUBJECT PARAGRAPH

**POCKET CALCULATOR - Cont**

**O**

Operation, Technical Principles of . . . . .	
Operation Under Unusual Conditions . . . . .	3-7
Operation Under Usual Conditions . . . . .	3-6
Operator's Controls and Indicators, Description and Use of. . . . .	3-4
Operator Preventive Maintenance Checks and Services	3-5
Organizational Preventive Maintenance Checks and Services..	3-14
Organizational Troubleshooting . . . . .	3-15

**P**

Preparation for Storage or Shipment . . . . .	3-17
Preventive Maintenance Checks and Services . . . . .	3-5, 3-14

**R**

Receipt, Service Upon . . . . .	3-13
---------------------------------	------

**S**

Scope . . . . .	3-1.1
Service Upon Receipt. . . . .	3-13
Services, Preventive Maintenance Checks and . . . . .	3-5, 3-14
Shipment, Preparation for Storage or . . . . .	3-17

**T**

Technical Principles of Operation . . . . .	
Troubleshooting . . . . .	3-9,3-15

**SUPPORT ITEMS**

**A**

Air Velocity Meter, Description and Use of Operator's Controls and Indicators . . . . .	9-4.8
Air Velocity Meter, Operating Procedures . . . . .	9-6.2f
Assembly and Preparation for Use, Manual Typewriter. . . . .	9-6.1

**B**

Ball, Pith, Air Velocity Meter, Replace . . . . .	9-10.6
Batteries, Hand Psychrometer, Replace . . . . .	9-10.2
Batteries, Still Picture (Instant) Camera Set, Replace . . . . .	9-10.7

INDEX - Cont

SUBJECT PARAGRAPH

SUPPORT ITEMS - Cont

C

Characteristics, Capabilities, and Features, Equipment . . . 9-2.1

D

Data, Equipment . . . . . 9-2.2

Description and Use of Operator's Controls  
and Indicators:

Air Velocity Meter. . . . . 9-4.8  
 Hand Psychrometer . . . . . 9-4.7  
 Magnifier Lamp. . . . . 9-4.1  
 Manual Typewriter . . . . . 9-4.6  
 Optical Range Finder. . . . . 9-4.9  
 Optical Tree Measurer . . . . . 9-4.10  
 Paper Trimmer . . . . . 9-4.5  
 Pin Punch Register. . . . . 9-4.4  
 Pocket Stereoscope. . . . . 9-4.3  
 Still Picture (Instant) Camera Set . . . . . 9-4.11  
 Vacuum Cleaner. . . . . 9-4.2  
 Description, Equipment . . . . . 9-2

E

Equipment Characteristics, Capabilities and Features . . . . 9-2.1  
 Equipment Data. . . . . 9-2.2  
 Equipment Description . . . . . 9-2

G

General Information . . . . . 9-1

H

Hand Psychrometer, Description and Use of  
Operator's Controls and Indicators . . . . . 9-4.7  
 Hand Psychrometer, Operating Procedures . . . . . 9-6.2e

I

Information, General . . . . . 9-1  
 Instructions, Lubrication . . . . . 9-11

L

Lamp, Hand Psychrometer, Replace . . . . . 9-10.3  
 Lamp in Magnifier Lamp Assembly, Replace . . . . . 9-10.1  
 Lubrication Instructions . . . . . 9-8, 9-11

INDEX - Cont

SUBJECT PARAGRAPH

SUPPORT ITEMS - Cont

M

Magnifier Lamp, Description and Use of  
 Operator's Controls and Indicators . . . . . 9-4.1  
 Magnifier Lamp, Operating Procedures . . . . . 9-6.2a  
 Magnifier Lamp Assembly, Replace . . . . . 9-16.1  
 Maintenance Procedures . . . . . 9-10, 9-16  
 Manual Typewriter, Assembly and Preparation  
 for Use . . . . . 9-6.1  
 Manual Typewriter, Description and Use of  
 Operator's Controls and Indicators . . . . . 9-4,6  
 Manual Typewriter, Remove/Install . . . . . 9-16.2

O

Operating Instructions on Decals and Instruction Plates . . . . . 9-6.4  
 Operation Under Unusual Conditions, Still  
 Picture (Instant) Camera Set . . . . . 9-7.1  
 Operation Under Usual Conditions:  
 Air Velocity Meter. . . . . 9-6.2f  
 Hand Psychrometer . . . . . 9-6.2e  
 Magnifier Lamp. . . . . 9-6.2a  
 Manual Typewriter . . . . . 9-6.1.1  
 Optical Range Finder. . . . . 9-6.1g  
 Optical Tree Measurer . . . . . 9-6.1h  
 Pin Punch Register. . . . . 9-6.2d  
 Pocket Stereoscope. . . . . 9-6.2c  
 Still Picture (Instant) Camera Set . . . . . 9-6.2i  
 Vacuum Cleaner. . . . . 9-6.2b  
 Optical Range Finder, Description and Use of  
 Operator's Controls and Indicators . . . . . 9-4.9  
 Optical Range Finder, Operating Procedures . . . . . 9-6.2g  
 Optical Tree Measurer, Description and Use of  
 Operator's Controls and Indicators . . . . . 9-4.10  
 Optical Tree Measurer, Operating Procedures . . . . . 9-6.2h

P

Paper Trimmer, Description and Use of  
 Operator's Controls and Indicators. . . . . 9-4.5  
 Pin Punch Register, Description and Use of  
 Operator's Controls and Indicators . . . . . 9-4.4  
 Pin Punch Register, Operating Procedures . . . . . 9-6.2d  
 Pocket Steroscope, Description and Use of  
 Operator's Controls and Indicators . . . . . 9-4.3  
 Pocket Stereoscope, Operating Procedures . . . . . 9-6.2c  
 Preparation for Movement. . . . . 9-6.3  
 Preparation for Storage or Shipment . . . . . 9-17  
 Preventive Maintenance Checks and Services . . . . . 9-5, 9-14  
 Procedures, Maintenance . . . . . 9-10, 9-16

INDEX - Cont

SUBJECT PARAGRAPH

SUPPORT ITEMS - Cont

R

Remove/Install Manual Typewriter . . . . . 9-16.2

Replace:

    Ball, Pith, Air Velocity Meter . . . . . 9-10.6

    Batteries, Hand Psychrometer . . . . . 9-10.2

    Batteries, Still Picture (Instant)

        Camera Set. . . . . 9-10.7

    Lamp, Hand Psychrometer.. . . . 9-10.3

    Lamp in Magnifier Lamp Assembly . . . . . 9-10.1

    Magnifier Lamp Assembly . . . . . 9-16.1

    Thermometers, Hand Psychrometer . . . . . 9-10.5

    Wick, Hand Psychrometer.. . . . 9-10.4

S

Scope . . . . . 9-1.1

Service Upon Receipt. . . . . 9-13

Services," Preventive Maintenance Checks and . . . . . 9-5, 9-14

Still Picture (Instant) Camera Set, Description  
and Use of Operator's Controls and  
Indicators. . . . . 9-4.11

Still Picture (Instant) Camera Set, Operating  
Procedures. . . . . 9-6.2i

Still Picture (Instant) Camera Set, Operation  
Under Unusual Conditions . . . . . 9-7.1

T

Technical Principles of Operation . . . . . 9-3

Thermometers, Hand Psychrometer, Replace . . . . . 9-10.5

Troubleshooting . . . . . 9-9, 9-15

V

Vacuum Cleaner, Description and Use of  
Operator's Controls and Indicators . . . . . 9-4.2

Vacuum Cleaner, Operating Procedures . . . . . 9-6.2b

W

Wick, Hand Psychrometer, Replace . . . . . 9-10.4

INDEX - Cont

SUBJECT PARAGRAPH

ULTRASONIC CLEANER

C

Characteristics, Capabilities, and Features. . . . .	6-2.1
Circuit Board, Replace . . . . .	6-16.3
Cleaning Pens . . . . .	6-6.1
Cleaning Small Parts. . . . .	6-6.1

D

Data, Equipment . . . . .	6-2.3
Description and Use of Operator's Controls and Indicators. .	6-4

E

Equipment Data. . . . .	6-2.3
Equipment Description.. . . .	6-2

G

General Information . . . . .	6-1
-------------------------------	-----

I

Information, General . . . . .	6-1
Instructions, Lubrication . . . . .	6-8, 6-11

L

Location and Description of Major Components . . . . .	6-2.2
--	-------

O

Operating Procedures . . . . .	6-6.1
Operation, Technical Principles of . . . . .	6-3
Operation Under Unusual Conditions . . . . .	6-7
Operation Under Usual Conditions . . . . .	6-6
Operator Preventive Maintenance Checks and Services . . . .	6-5
Organizational Preventive Maintenance Checks and Services . . . . .	6-14
Organizational Troubleshooting . . . . .	6-15



INDEX - Cont

SUBJECT PARAGRAPH

ULTRASONIC CLEANER - Cont

P

Parts, Cleaning . . . . .	6-6.1
Pens, Cleaning. . . . .	6-6.1
Power Cord, Replace . . . . .	6-16.1
Power Switch, Replace . . . . .	6-16.2
Preparation for Storage or Shipment . . . . .	6-17
Preventive Maintenance Checks and Services . . . . .	6-5, 6-14

R

Receipt, Service Upon . . . . .	6-13
Replace:	
Circuit Board . . . . .	6-16.3
Power Cord. . . . .	6-16.1
Power Switch. . . . .	6-16.2

S

Scope . . . . .	6-1.1
Service Upon Receipt. . . . .	6-13
Services, Preventive Maintenance Checks and . . . . .	6-5, 6-14
Shipment, Preparation for Storage or . . . . .	6-17

T

Technical Principles of Operation . . . . .	6-3
Troubleshooting . . . . .	6-9, 6-15



By Order of the Secretary of the Army:

**JOHN A. WICKHAM, JR.**  
*General, United States Army*  
*Chief of Staff*

Official:

**DONALD J. DELANDRO**  
*Brigadier General, United States Army*  
*The Adjutant General*

DISTRIBUTION:

To be distributed in accordance with DA Form 12-25A, Operator, Organizational, Direct Support and General Support Maintenance Requirements for Mapping Equipment.



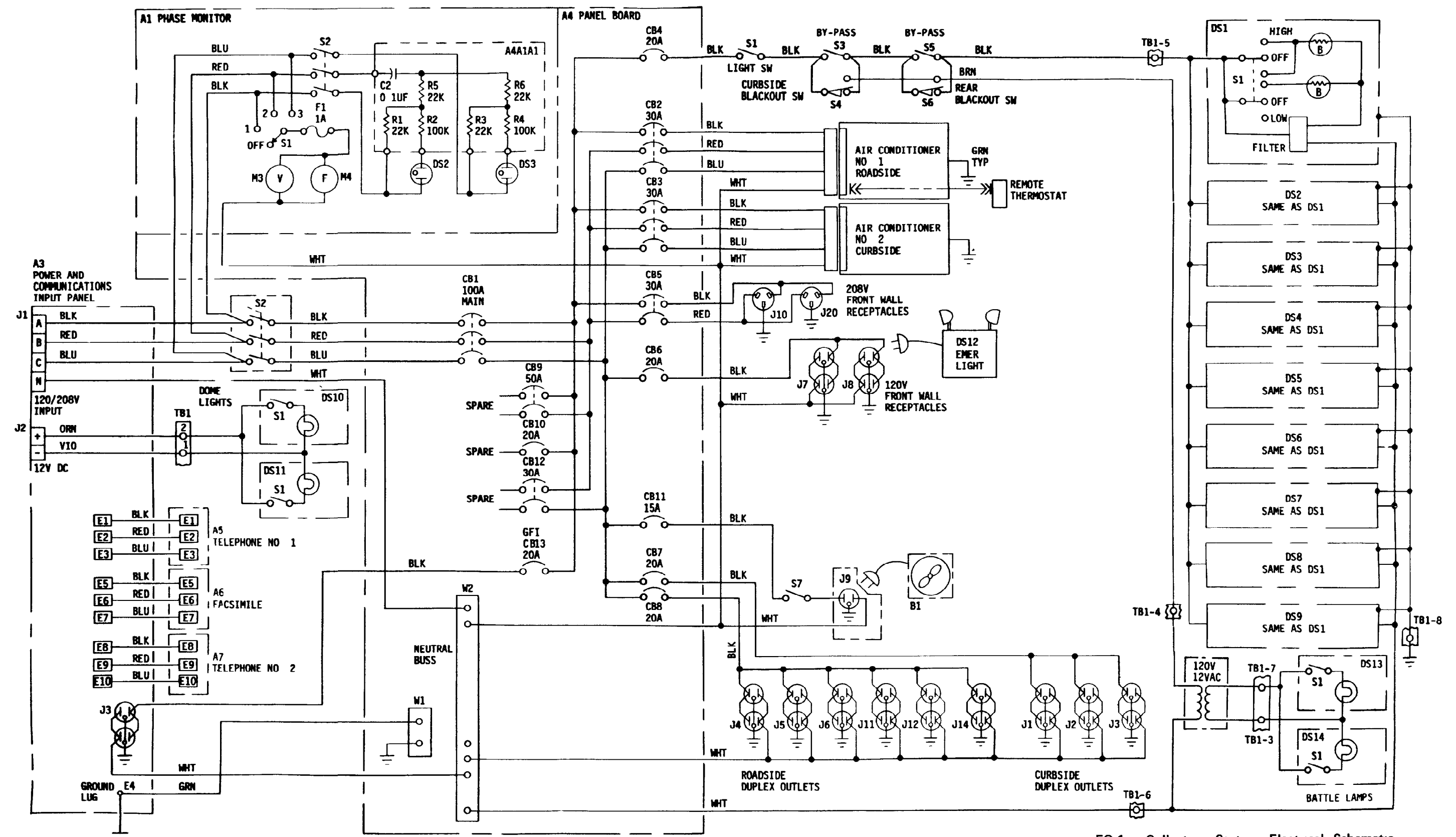

FO 1 Collection Section Electrical Schematic





RECOMMENDED CHANGES TO EQUIPMENT TECHNICAL PUBLICATIONS



THEN... JOT DOWN THE DOPE ABOUT IT ON THIS FORM. CAREFULLY TEAR IT OUT, FOLD IT AND DROP IT IN THE MAIL!

SOMETHING WRONG WITH THIS PUBLICATION?

FROM: (PRINT YOUR UNIT'S COMPLETE ADDRESS)  
**PFC JOHN DOE**  
**COA, 3d ENGINEER BN**  
**FT. LEANARDWOOD, MD 63108**  
 DATE SENT

PUBLICATION NUMBER: **TM 5-6675-322-14**  
 PUBLICATION DATE: **20 June 1985**  
 PUBLICATION TITLE: **Topographic Support System, Collection Section**

BE EXACT. PIN-POINT WHERE IT IS				IN THIS SPACE TELL WHAT IS WRONG AND WHAT SHOULD BE DONE ABOUT IT:
PAGE NO	PARA-GRAPH	FIGURE NO	TABLE NO	
<b>6</b>	<b>2-1 a</b>			<i>In line 6 of paragraph 2-1 a the manual states the engine has <u>6</u> cylinders. The engine on my set only has <u>4</u> cylinders. Change the manual to show <u>4</u> cylinders.</i>
<b>B1</b>		<b>4-3</b>		<i>Callout 16 on figure 4-3 is pointing at a <u>bolt</u>. In key to figure 4-3, item 16 is called a <u>shim</u> - Please correct one or the other.</i>
<b>125</b>	<b>line 20</b>			<i>I ordered a gasket, item 19 on figure B-16 by NSN 2 910-00-762-3001. I got a gasket but it doesn't fit. Supply says I got what I ordered, so the NSN is wrong. Please give me a good NSN</i>

PRINTED NAME, GRADE OR TITLE, AND TELEPHONE NUMBER: **JOHN DOE, PFC (268) 317-7111**  
 SIGN HERE: **JOHN DOE**

TEAR ALONG PERFORATED LINE



FILL IN YOUR  
UNIT'S ADDRESS

FOLD BACK

DEPARTMENT OF THE ARMY

OFFICIAL BUSINESS  
PENALTY FOR PRIVATE USE \$300

POSTAGE AND FEES PAID  
DEPARTMENT OF THE ARMY  
DOD 314



COMMANDER  
US ARMY TROOP SUPPORT COMMAND  
ATTN: AMSTR-MPS  
4300 GOODFELLOW BOULEVARD  
ST. LOUIS, MO 63120-1798

TEAR ALONG PERFORATED LINE

RECOMMENDED CHANGES TO EQUIPMENT TECHNICAL PUBLICATIONS



THEN... JOT DOWN THE DOPE ABOUT IT ON THIS FORM. CAREFULLY TEAR IT OUT. FOLD IT AND DROP IT IN THE MAIL!

**SOMETHING WRONG WITH THIS PUBLICATION?**

FROM: (PRINT YOUR UNIT'S COMPLETE ADDRESS)

DATE SENT

PUBLICATION NUMBER  
TM 5-6675-322-14

PUBLICATION DATE  
20 June 1985

PUBLICATION TITLE  
Topographic Support System, Collection Section

BE EXACT... PIN-POINT WHERE IT IS

PAGE NO.	PARA-GRAPH	FIGURE NO.	TABLE NO.

IN THIS SPACE TELL WHAT IS WRONG AND WHAT SHOULD BE DONE ABOUT IT:

PRINTED NAME, GRADE OR TITLE, AND TELEPHONE NUMBER

SIGN HERE:

TEAR ALONG PERFORATED LINE

FILL IN YOUR  
UNIT'S ADDRESS

FOLD BACK

DEPARTMENT OF THE ARMY

OFFICIAL BUSINESS  
PENALTY FOR PRIVATE USE \$300

POSTAGE AND FEES PAID  
DEPARTMENT OF THE ARMY  
DOD 314



COMMANDER  
US ARMY TROOP SUPPORT COMMAND  
ATTN: AMSTR-MPS  
4300 GOODFELLOW BOULEVARD  
ST. LOUIS, MO 63120-1798

TEAR ALONG PERFORATED LINE

RECOMMENDED CHANGES TO EQUIPMENT TECHNICAL PUBLICATIONS



THEN... JOT DOWN THE DOPE ABOUT IT ON THIS FORM. CAREFULLY TEAR IT OUT. FOLD IT AND DROP IT IN THE MAIL!

SOMETHING WRONG WITH THIS PUBLICATION?

FROM: (PRINT YOUR UNIT'S COMPLETE ADDRESS)

DATE SENT

PUBLICATION NUMBER

TM 5-6675-322-14

PUBLICATION DATE

20 June 1985

PUBLICATION TITLE

Topographic Support System, Collection Section

BE EXACT... PIN-POINT WHERE IT IS

PAGE NO	PARA-GRAPH	FIGURE NO	TABLE NO

IN THIS SPACE TELL WHAT IS WRONG AND WHAT SHOULD BE DONE ABOUT IT:

PRINTED NAME, GRADE OR TITLE, AND TELEPHONE NUMBER

SIGN HERE

TEAR ALONG PERFORATED LINE

DA FORM 2028-2  
1 JUL 79

PREVIOUS EDITIONS ARE OBSOLETE.  
DRSTS-M Overprint 2, 1 Nov 80.

P.S.--IF YOUR OUTFIT WANTS TO KNOW ABOUT YOUR RECOMMENDATION MAKE A CARBON COPY OF THIS AND GIVE IT TO YOUR HEADQUARTERS

FILL IN YOUR  
UNIT'S ADDRESS

FOLD BACK

DEPARTMENT OF THE ARMY

---

---

OFFICIAL BUSINESS  
PENALTY FOR PRIVATE USE \$300

POSTAGE AND FEES PAID  
DEPARTMENT OF THE ARMY  
DOD 314



TEAR ALONG PERFORATED LINE

COMMANDER  
US ARMY TROOP SUPPORT COMMAND  
ATTN: AMSTR-MPS  
4300 GOODFELLOW BOULEVARD  
ST. LOUIS, MO 63120-1798

RECOMMENDED CHANGES TO EQUIPMENT TECHNICAL PUBLICATIONS



THEN... JOT DOWN THE DOPE ABOUT IT ON THIS FORM. CAREFULLY TEAR IT OUT, FOLD IT AND DROP IT IN THE MAIL!

SOMETHING WRONG WITH THIS PUBLICATION?

FROM: (PRINT YOUR UNIT'S COMPLETE ADDRESS)

DATE SENT

PUBLICATION NUMBER

TM 5-6675-322-14

PUBLICATION DATE

20 June 1985

PUBLICATION TITLE

Topographic Support System, Collection Section

BE EXACT... PIN-POINT WHERE IT IS

PAGE  
NO

PARA-  
GRAPH

FIGURE  
NO

TABLE  
NO

IN THIS SPACE TELL WHAT IS WRONG AND WHAT SHOULD BE DONE ABOUT IT:

TEAR ALONG PERFORATED LINE

PRINTED NAME, GRADE OR TITLE, AND TELEPHONE NUMBER

SIGN HERE

DA FORM 2028-2  
1 JUL 79

PREVIOUS EDITIONS ARE OBSOLETE.  
DRSTS-M Overprint 2, 1 Nov 80.

P.S.--IF YOUR OUTFIT WANTS TO KNOW ABOUT YOUR RECOMMENDATION MAKE A CARBON COPY OF THIS AND GIVE IT TO YOUR HEADQUARTERS

FILL IN YOUR  
UNIT'S ADDRESS

FOLD BACK

DEPARTMENT OF THE ARMY

\_\_\_\_\_  
\_\_\_\_\_

OFFICIAL BUSINESS  
PENALTY FOR PRIVATE USE \$300

POSTAGE AND FEES PAID  
DEPARTMENT OF THE ARMY  
DOD 314



TEAR ALONG PERFORATED LINE

COMMANDER  
US ARMY TROOP SUPPORT COMMAND  
ATTN: AMSTR-MPS  
4300 GOODFELLOW BOULEVARD  
ST. LOUIS, MO 63120-1798

# The Metric System and Equivalents

## Linear Measure

1 centimeter = 10 millimeters = .39 inch  
 1 decimeter = 10 centimeters = 3.94 inches  
 1 meter = 10 decimeters = 39.37 inches  
 1 dekameter = 10 meters = 32.8 feet  
 1 hectometer = 10 dekameters = 328.08 feet  
 1 kilometer = 10 hectometers = 3,280.8 feet

## Weights

1 centigram = 10 milligrams = .15 grain  
 1 decigram = 10 centigrams = 1.54 grains  
 1 gram = 10 decigram = .035 ounce  
 1 dekagram = 10 grams = .35 ounce  
 1 hectogram = 10 dekagrams = 3.52 ounces  
 1 kilogram = 10 hectograms = 2.2 pounds  
 1 quintal = 100 kilograms = 220.46 pounds  
 1 metric ton = 10 quintals = 1.1 short tons

## Liquid Measure

1 centiliter = 10 milliliters = .34 fl. ounce  
 1 deciliter = 10 centiliters = 3.38 fl. ounces  
 1 liter = 10 deciliters = 33.81 fl. ounces  
 1 dekaliter = 10 liters = 2.64 gallons  
 1 hectoliter = 10 dekaliters = 26.42 gallons  
 1 kiloliter = 10 hectoliters = 264.18 gallons

## Square Measure

1 sq. centimeter = 100 sq. millimeters = .155 sq. inch  
 1 sq. decimeter = 100 sq. centimeters = 15.5 sq. inches  
 1 sq. meter (centare) = 100 sq. decimeters = 10.76 sq. feet  
 1 sq. dekameter (are) = 100 sq. meters = 1,076.4 sq. feet  
 1 sq. hectometer (hectare) = 100 sq. dekameters = 2.47 acres  
 1 sq. kilometer = 100 sq. hectometers = .386 sq. mile

## Cubic Measure

1 cu. centimeter = 1000 cu. millimeters = .06 cu. inch  
 1 cu. decimeter = 1000 cu. centimeters = 61.02 cu. inches  
 1 cu. meter = 1000 cu. decimeters = 35.31 cu. feet

## Approximate Conversion Factors

To change	To	Multiply by	To change	To	Multiply by
inches	centimeters	2.540	ounce-inches	newton-meters	.007062
feet	meters	.305	centimeters	inches	.394
yards	meters	.914	meters	feet	3.280
miles	kilometers	1.609	meters	yards	1.094
square inches	square centimeters	6.451	kilometers	miles	.621
square feet	square meters	.093	square centimeters	square inches	.155
square yards	square meters	.836	square meters	square feet	10.764
square miles	square kilometers	2.590	square meters	square yards	1.196
acres	square hectometers	.405	square kilometers	square miles	.386
cubic feet	cubic meters	.028	square hectometers	acres	2.471
cubic yards	cubic meters	.765	cubic meters	cubic feet	35.315
fluid ounces	milliliters	29,573	cubic meters	cubic yards	1.308
pints	liters	.473	milliliters	fluid ounces	.034
quarts	liters	.946	liters	pints	2.113
gallons	liters	3.785	liters	quarts	1.057
ounces	grams	28.349	liters	gallons	.264
pounds	kilograms	.454	grams	ounces	.035
short tons	metric tons	.907	kilograms	pounds	2.205
pound-feet	newton-meters	1.356	metric tons	short tons	1.102
pound-inches	newton-meters	.11296			

## Temperature (Exact)

°F	Fahrenheit temperature	5/9 (after subtracting 32)	Celsius temperature	°C	°C
----	------------------------	----------------------------	---------------------	----	----



